

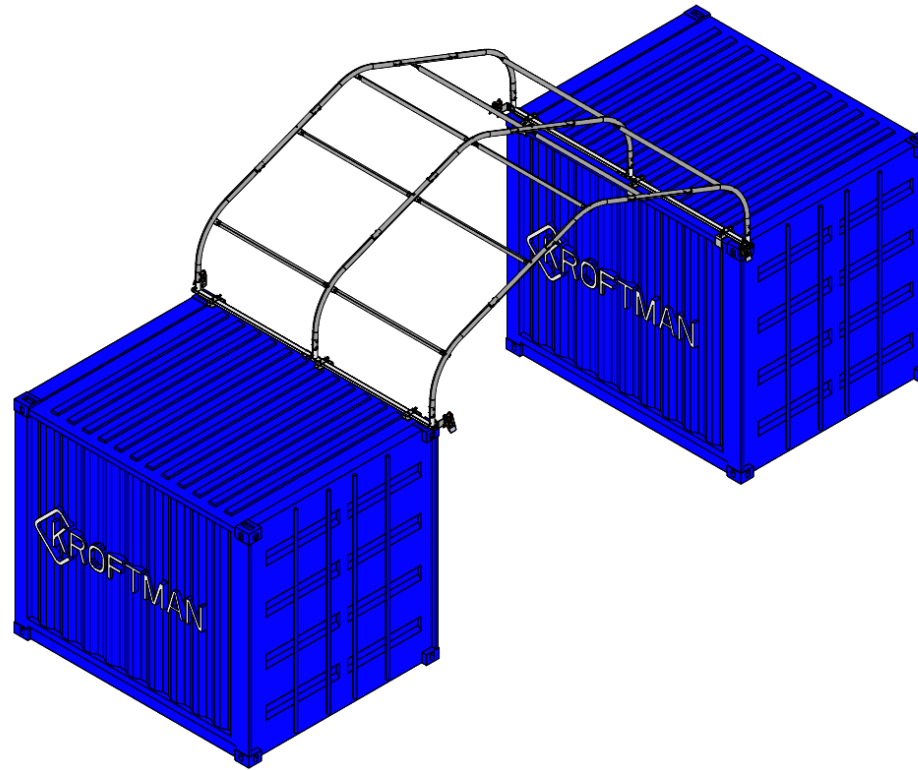



Container shelter/ Containerüberdachung / Abris sur containers

KROFTMAN CT-S-403



Assembly manual for main frame
Montageanleitung für den Hauptrahmen
Manuel d'assemblage du cadre principal

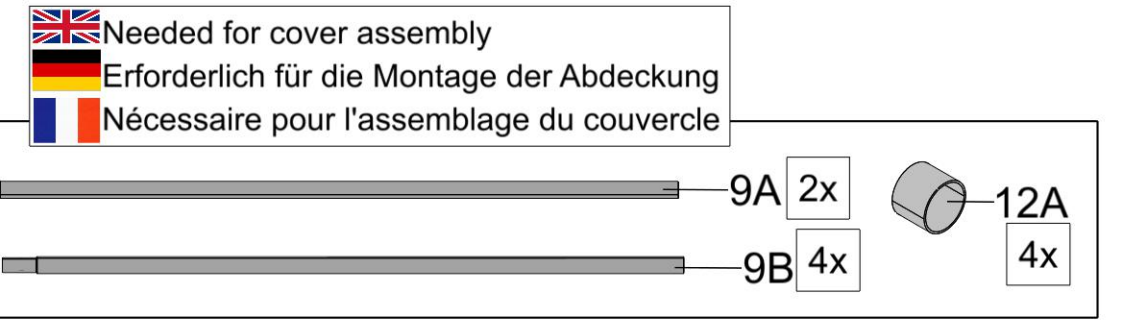
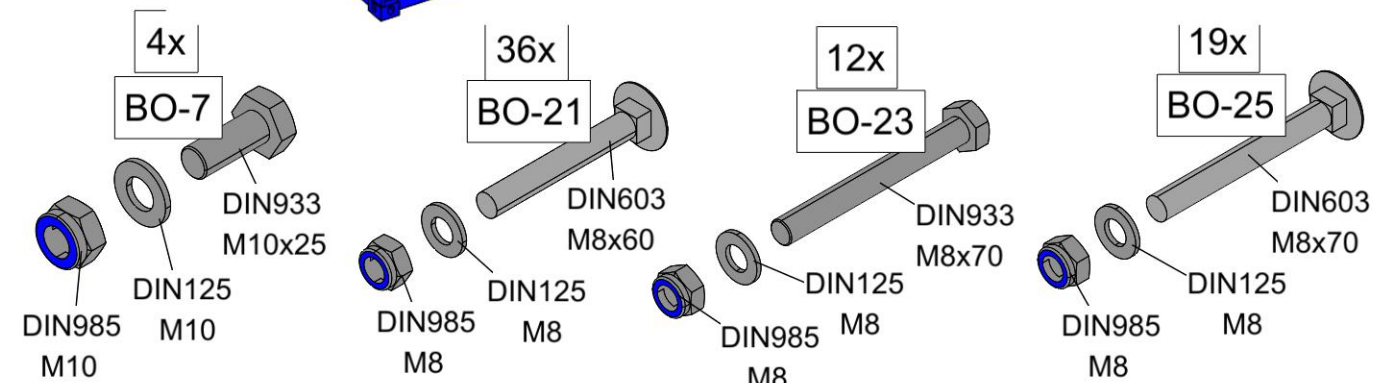
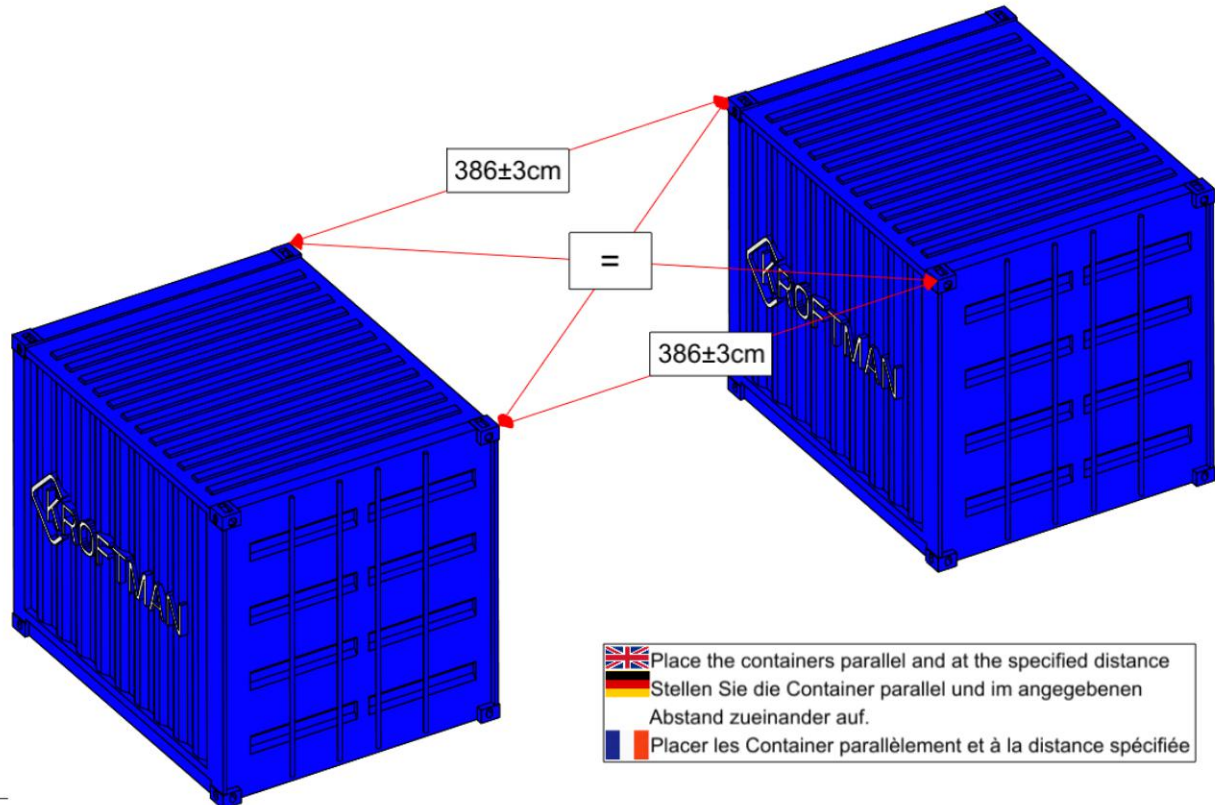
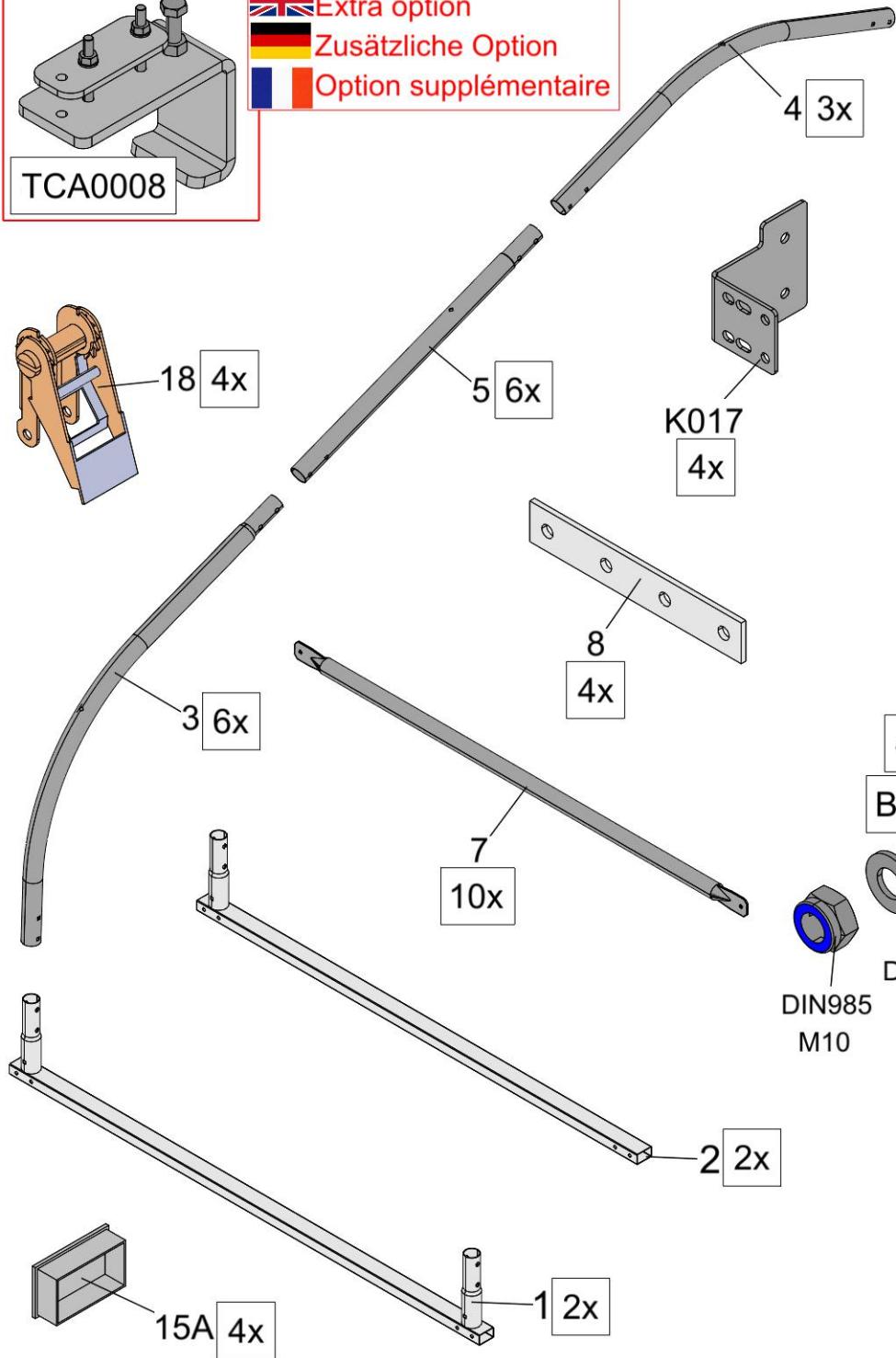
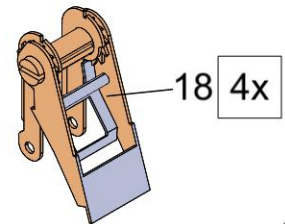

 Extra option
 Zusätzliche Option
 Option supplémentaire

TCA0008



-  Place and symmetrically align the base rail on top of the container. Mark the position of the TCA0008 clamps as close to the tubes as possible, remove the base rail and place the clamps. Level the clamps and tighten the nuts hand-tight.
-  Setzen Sie die Grundschiene auf den Container und richten Sie sie symmetrisch aus. Die Position der TCA0008-Klemmen so nah wie möglich an den Rohren markieren, die Grundschiene entfernen und die Klemmen anbringen. Richten Sie die Klemmen aus und ziehen Sie die Muttern handfest an.
-  Placer et aligner symétriquement le rail de base sur le dessus du conteneur. Marquer la position des pinces TCA0008 le plus près possible des tubes, retirer le rail de base et placer les pinces. Mettez les pinces à niveau et serrez les écrous à la main.

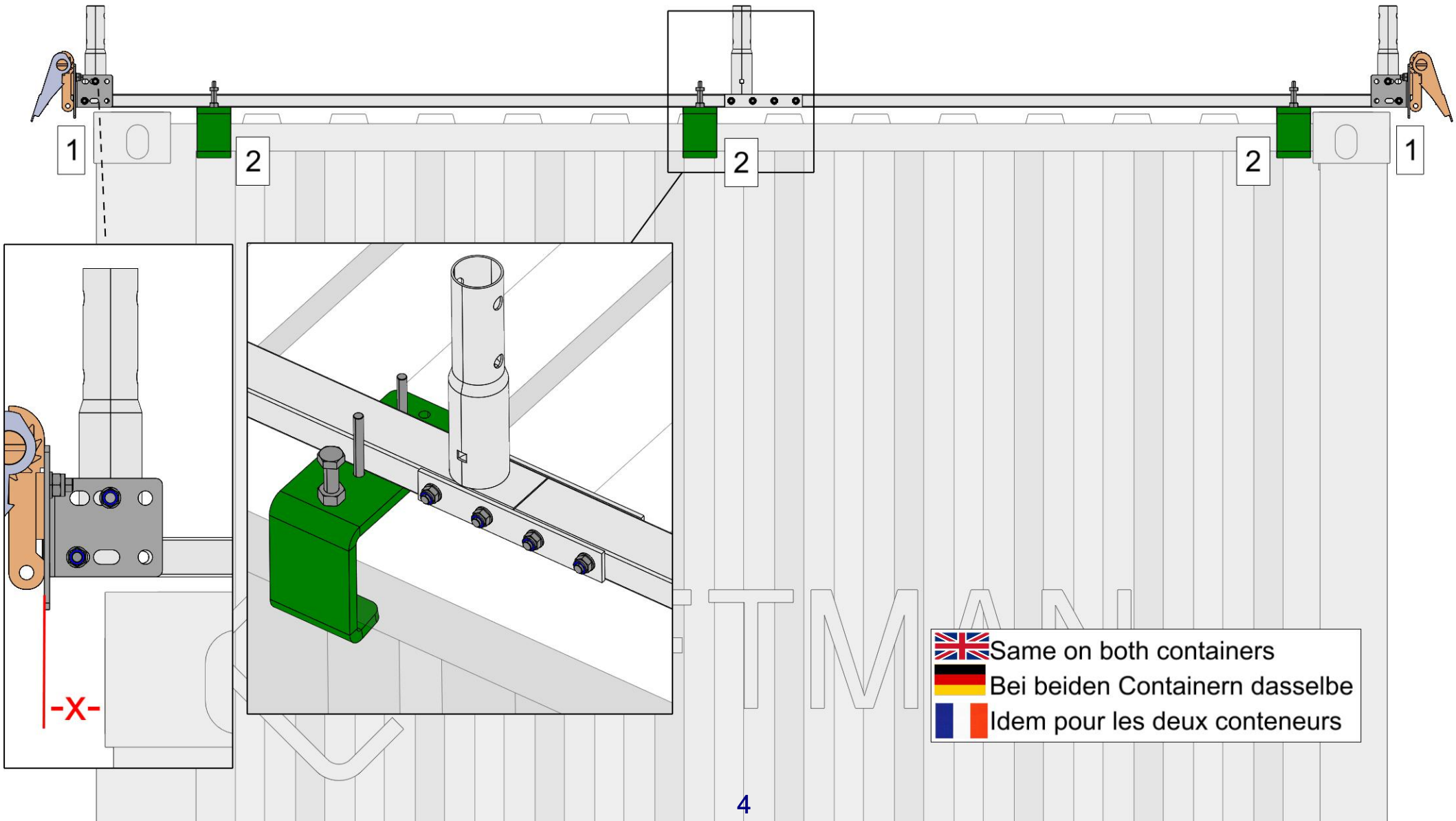

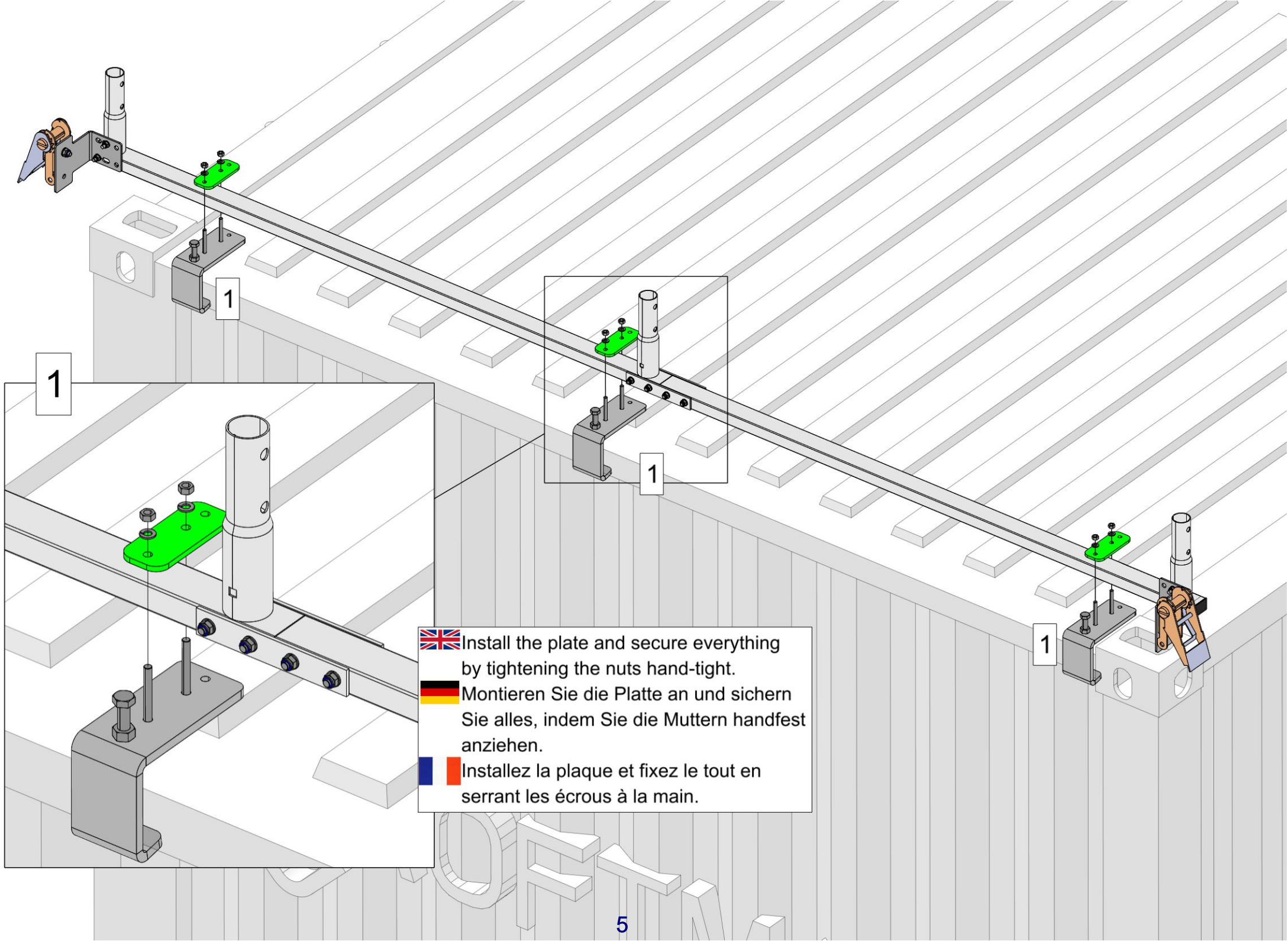



1

1

1

1

 Install the plate and secure everything by tightening the nuts hand-tight.

 Montieren Sie die Platte an und sichern Sie alles, indem Sie die Muttern handfest anziehen.

 Installez la plaque et fixez le tout en serrant les écrous à la main.

3xA

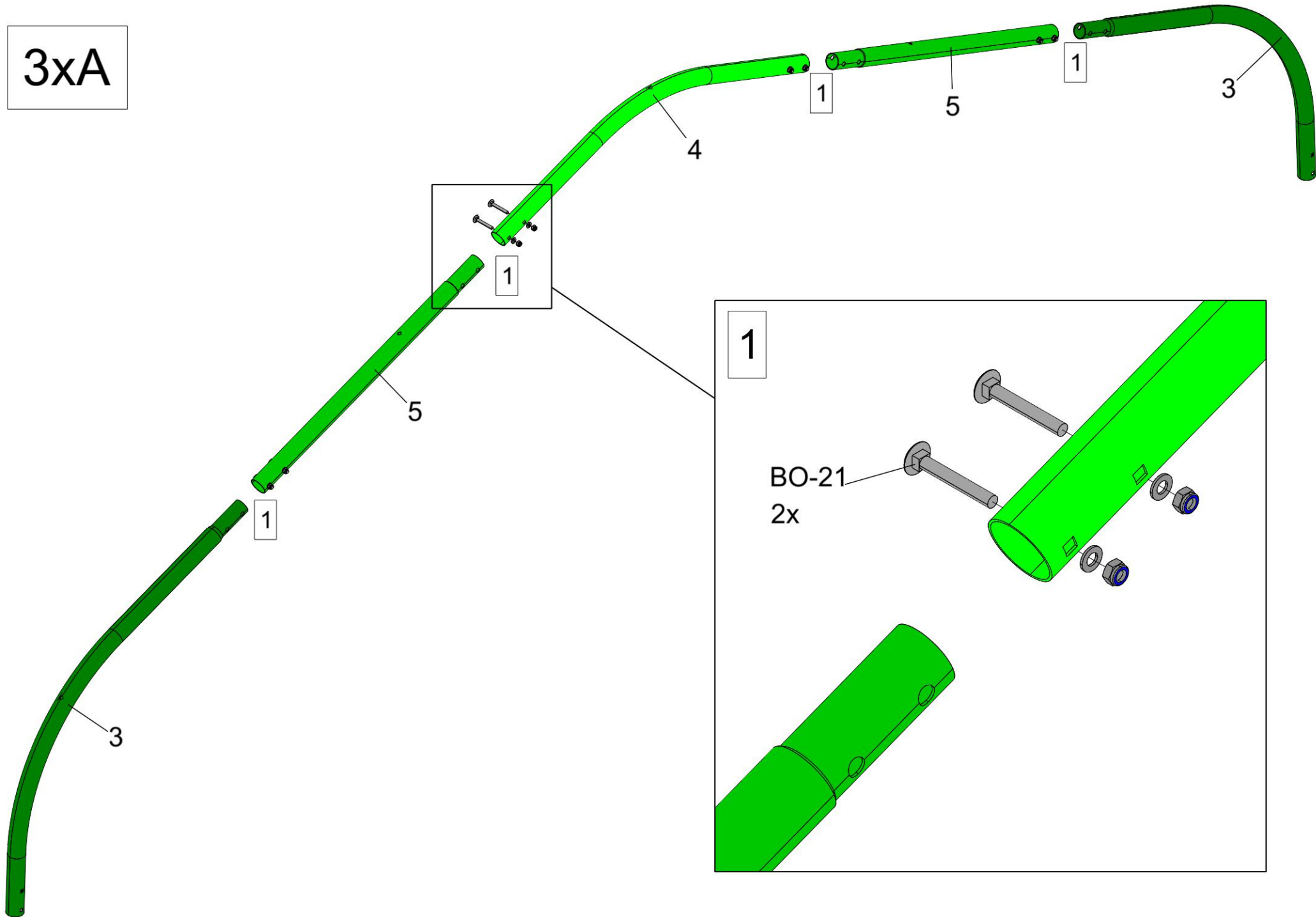

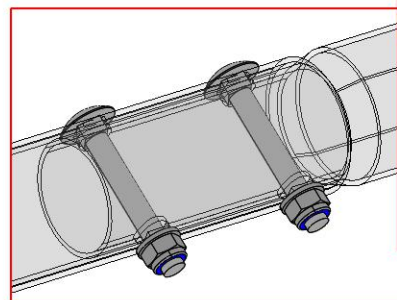
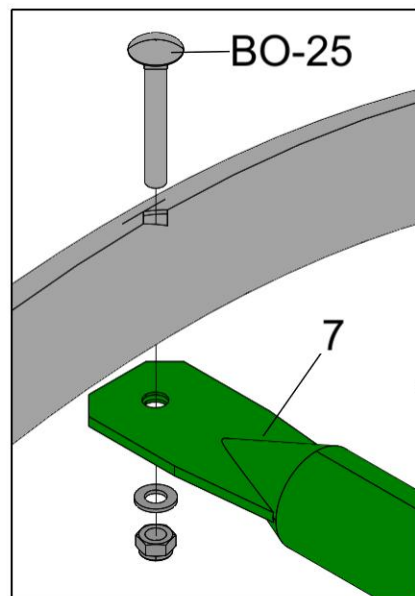
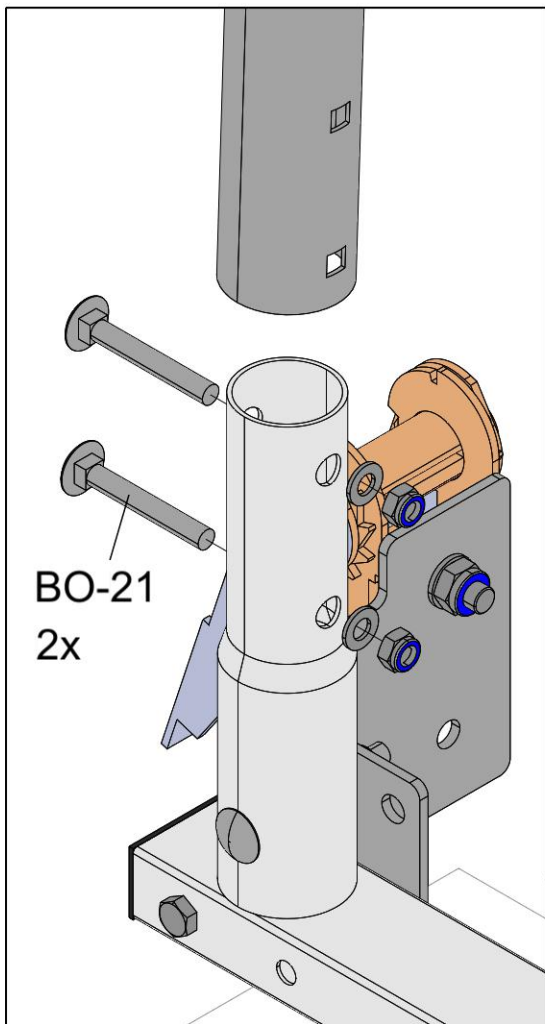

 When placing the first and last arch make sure the boltheads point outwards

 Achten Sie beim Anbringen des ersten und letzten Bogens darauf, dass der Schraubenkopf nach außen zeigt.

 Lorsque vous placez le premier et le dernier arc, veillez à ce que la tête de boulon soit orientée vers l'extérieur.

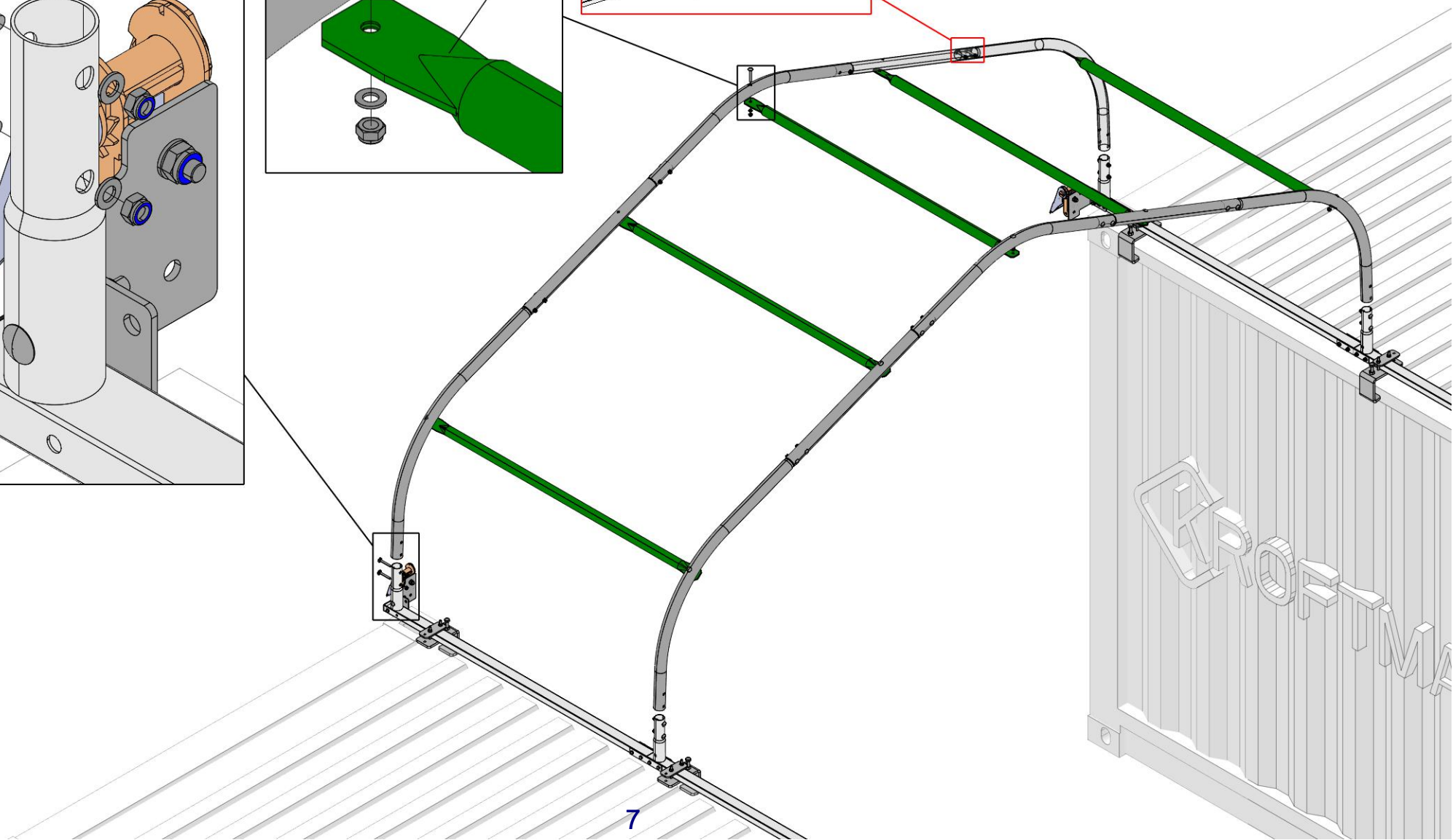

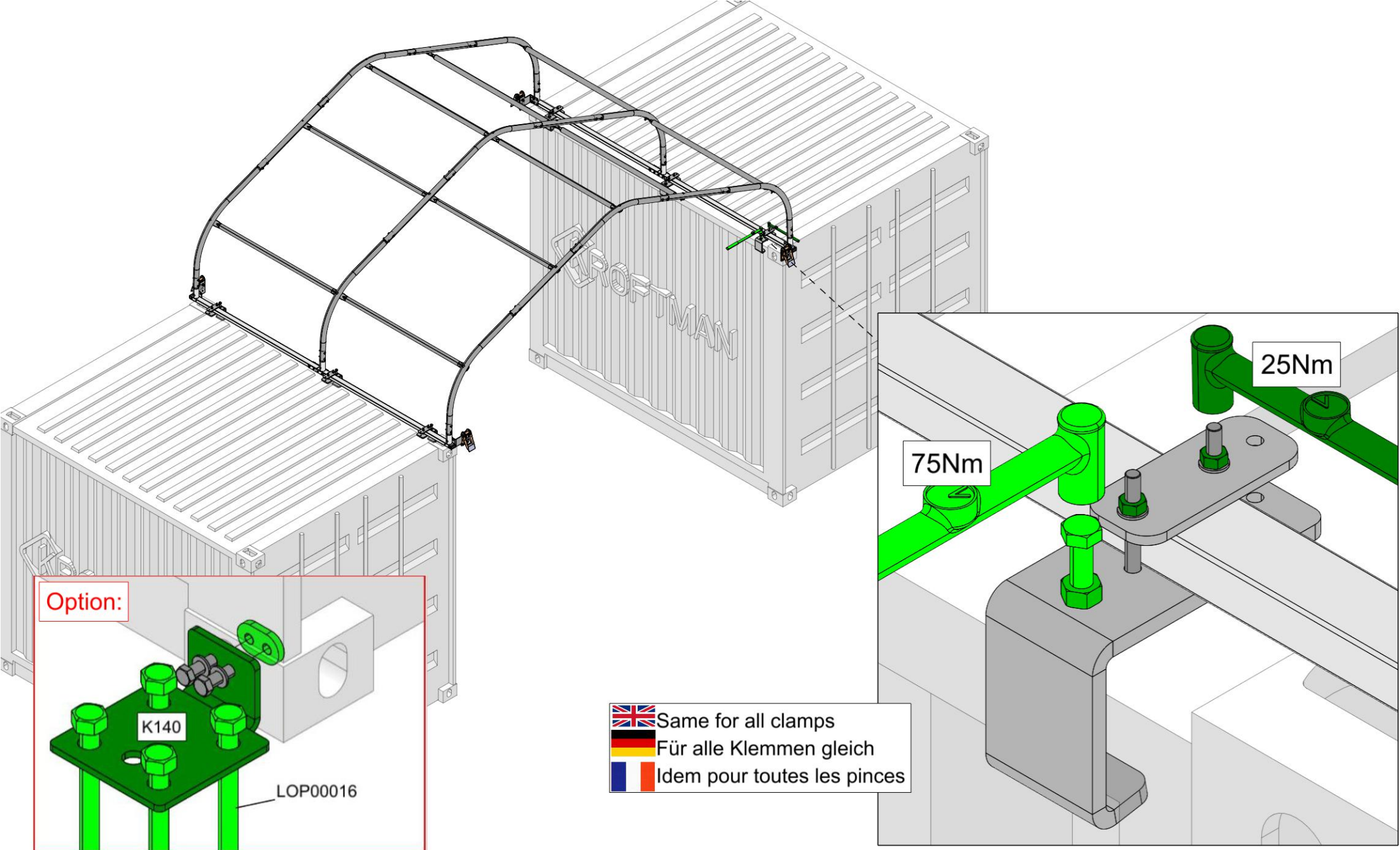







Option:

K140

LOP00016

 Same for all clamps
 Für alle Klemmen gleich
 Idem pour toutes les pinces

 Important: add permanent weight in containers according to calculations or use optional container anchoring bracket.
 Wichtig: Fügen Sie den Containern ein dauerhaftes Gewicht gemäß den Berechnungen hinzu oder verwenden Sie die optionalen Container- Verankerungsklemmen.
 Important : ajoutez le poids permanent dans les conteneurs selon les calculs ou utilisez le support d'ancrage de conteneur en option.