

**Genehmigung / Approval / Goedkeuring**

Kundenname: Client name: Klantnaam:	Firmenstempel: Company stamp: Firmastempel:
Datum: Date: Datum:	
Unterschrift: Signature: Handtekening:	

LASERCUT ACCORDING: EN-ISO 9013-5-4-1		MATERIAL: See List	
MATERIAL CERTIFICATE: 3.1 (OR 2.2 WHEN S235JR)		TREATMENT: -	
GALVANIZING ACCORDING: EN ISO 1461		STATUS: Released	
BEND RADIUS UNLESS DEFINED R <sub>i</sub> =t			
TOLERANCES UNLESS OTHERWISE SPECIFIED:			
GENERAL ROUGHNESS R <sub>a</sub> ✓	DIMENSION: ± 10	ANGLE: ± °	MODEL NUMBER <b>LCA00150</b>
		REVISION: <b>0</b>	
DESCRIPTION: <b>Storage Building H8-33</b>			
SCALE: 1:100	UNITS: mm	PROJECTION: 	MODIFIED ON: 08-09-2023 APPROVED ON: 08-09-2023
		MODIFIED BY: AVA	APPROVED BY: BVB
		MASS: 4968,5 kg	Sheet 1 of 4 Size: A2

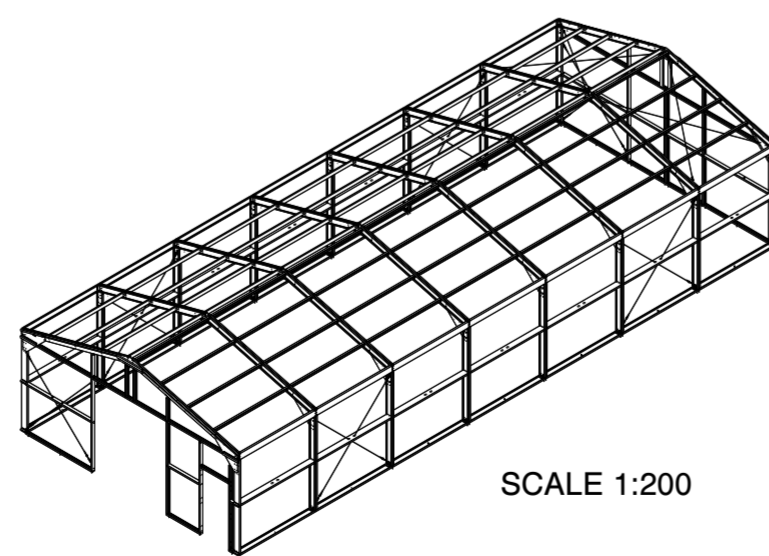
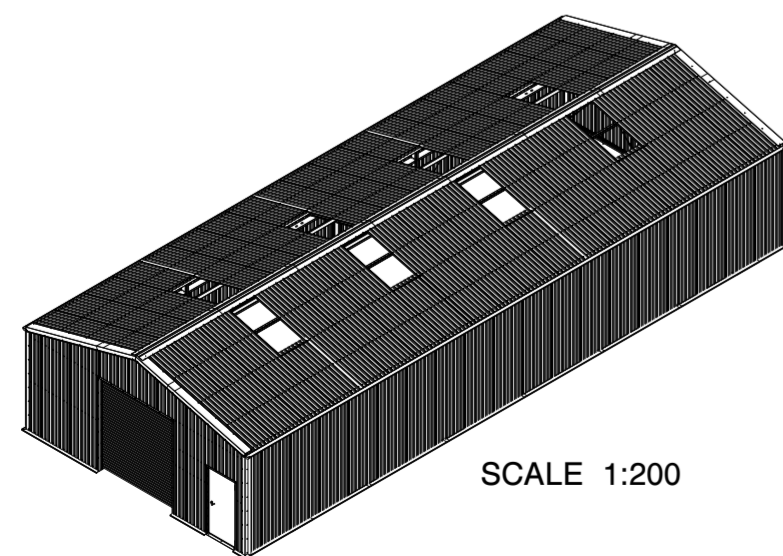
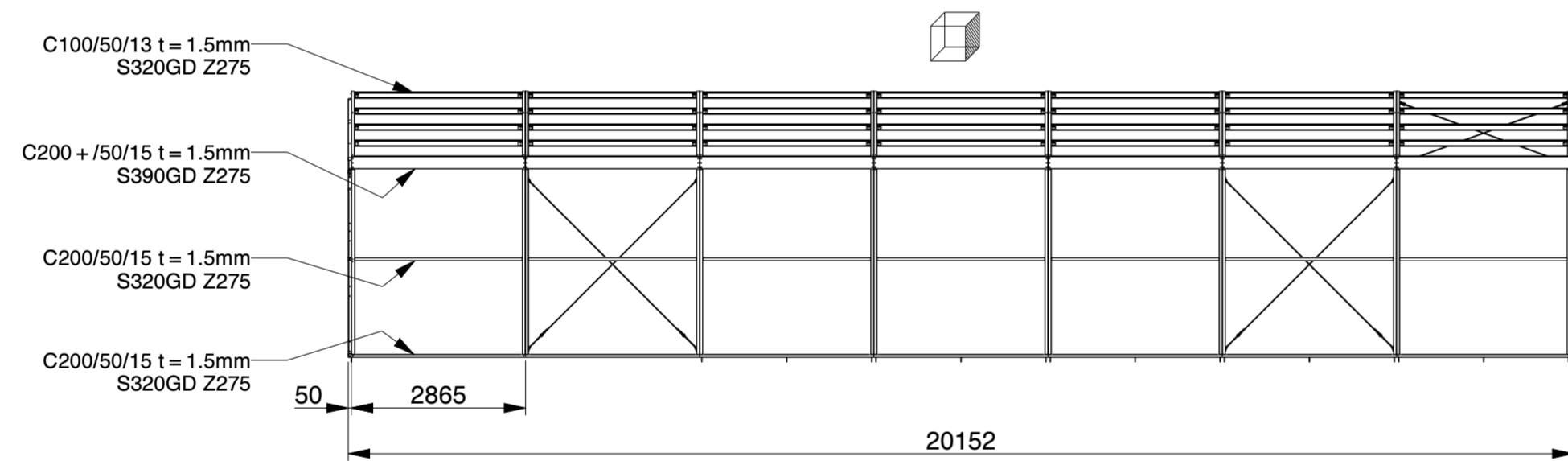
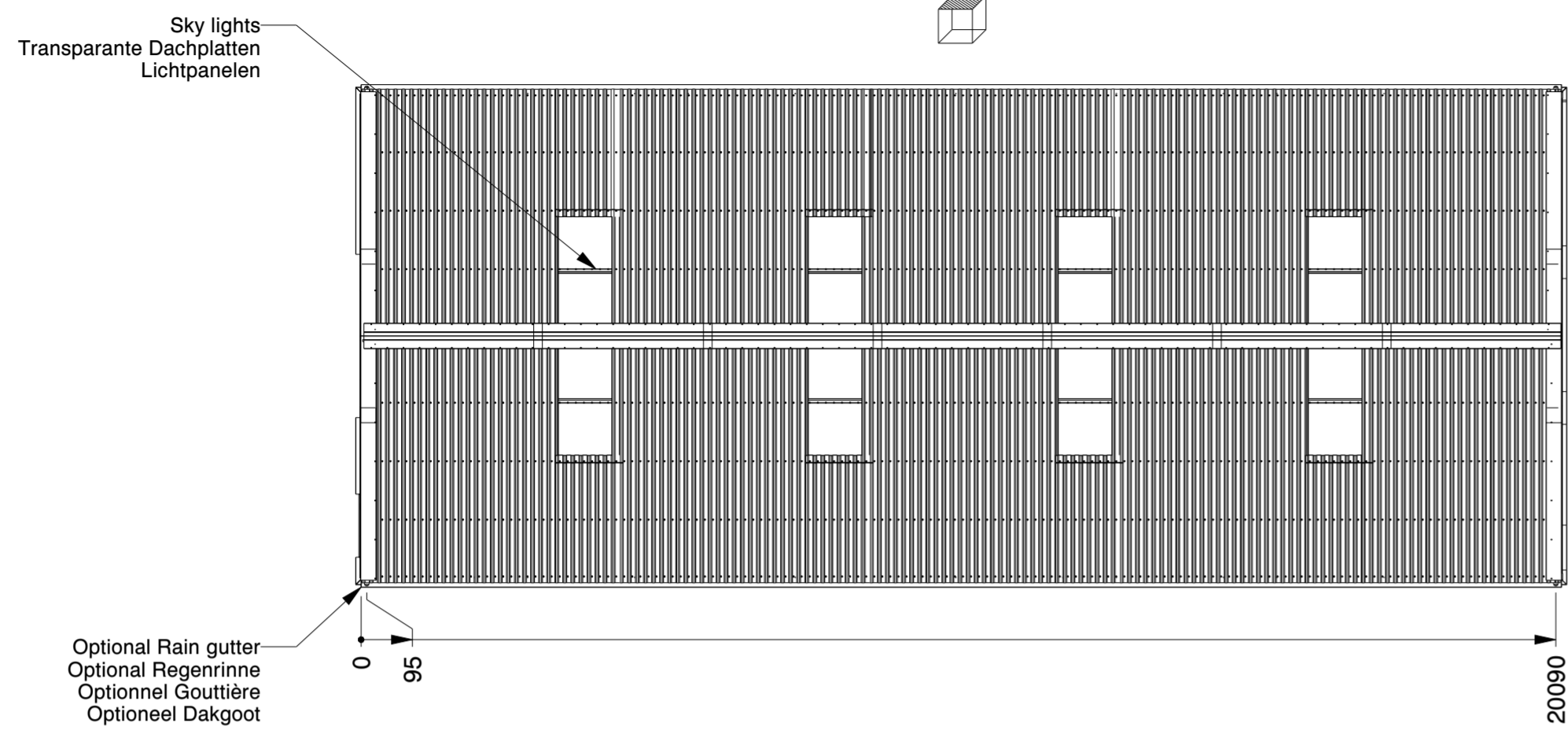

**Genehmigung / Approval / Goedkeuring**

Kundenname: Client name: Klantnaam:		Firmenstempel: Company stamp: Firmastempel:	
Datum: Date: Datum:			
Unterschrift: Signature: Handtekening:			

TRAPEZBLECH	CORRUGATED STEEL PANEL	TÔLE TRAPÉZOÏDALE
POLYESTERBESCHICHTUNG	POLYESTER COATING	REVÊTEMENT POLYESTER
0.5MM STAHL	0.5MM STEEL	0.5MM MÉTAL

LASERCUT ACCORDING: EN-ISO 9013-5-4-1		MATERIAL: See List	
MATERIAL CERTIFICATE: 3.1 (OR 2.2 WHEN S235JR)		TREATMENT: -	
GALVANIZING ACCORDING: EN ISO 1461		STATUS: Released	
BEND RADIUS UNLESS DEFINED R <sub>i</sub> =t		MODEL NUMBER	REVISION:
TOLERANCES UNLESS OTHERWISE SPECIFIED:		LCA00150	0
GENERAL ROUGHNESS R <sub>a</sub> ✓	DIMENSION: ± 10	DESCRIPTION: <b>Storage Building H8-33</b>	
ANGLE: ± °	PROJECTION: 	MODIFIED ON: 08-09-2023	APPROVED ON: 08-09-2023
SCALE: 1:100	UNITS: mm	MODIFIED BY: AVA	APPROVED BY: BVB
		MASS: 4968,5 kg	Sheet 2 of 4
			Size: A2



© KROFTMAN STRUCTURES B.V. Duplication and copying without written permission of the owner is prohibited

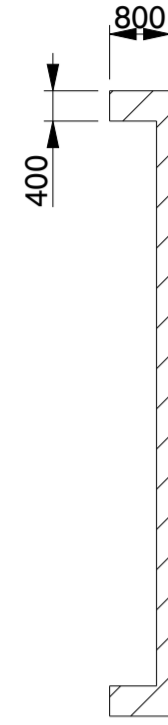

SECTION E-E

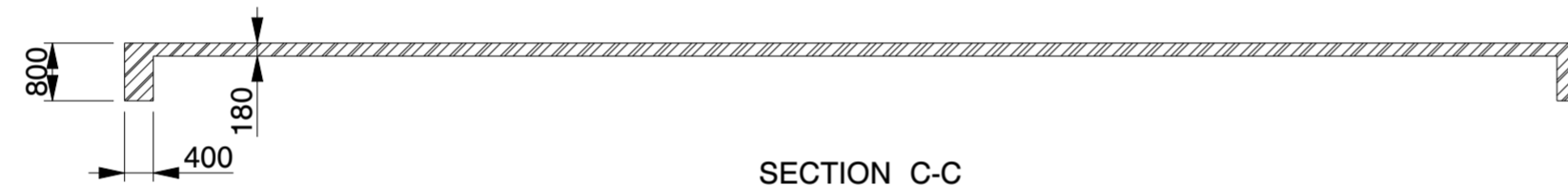
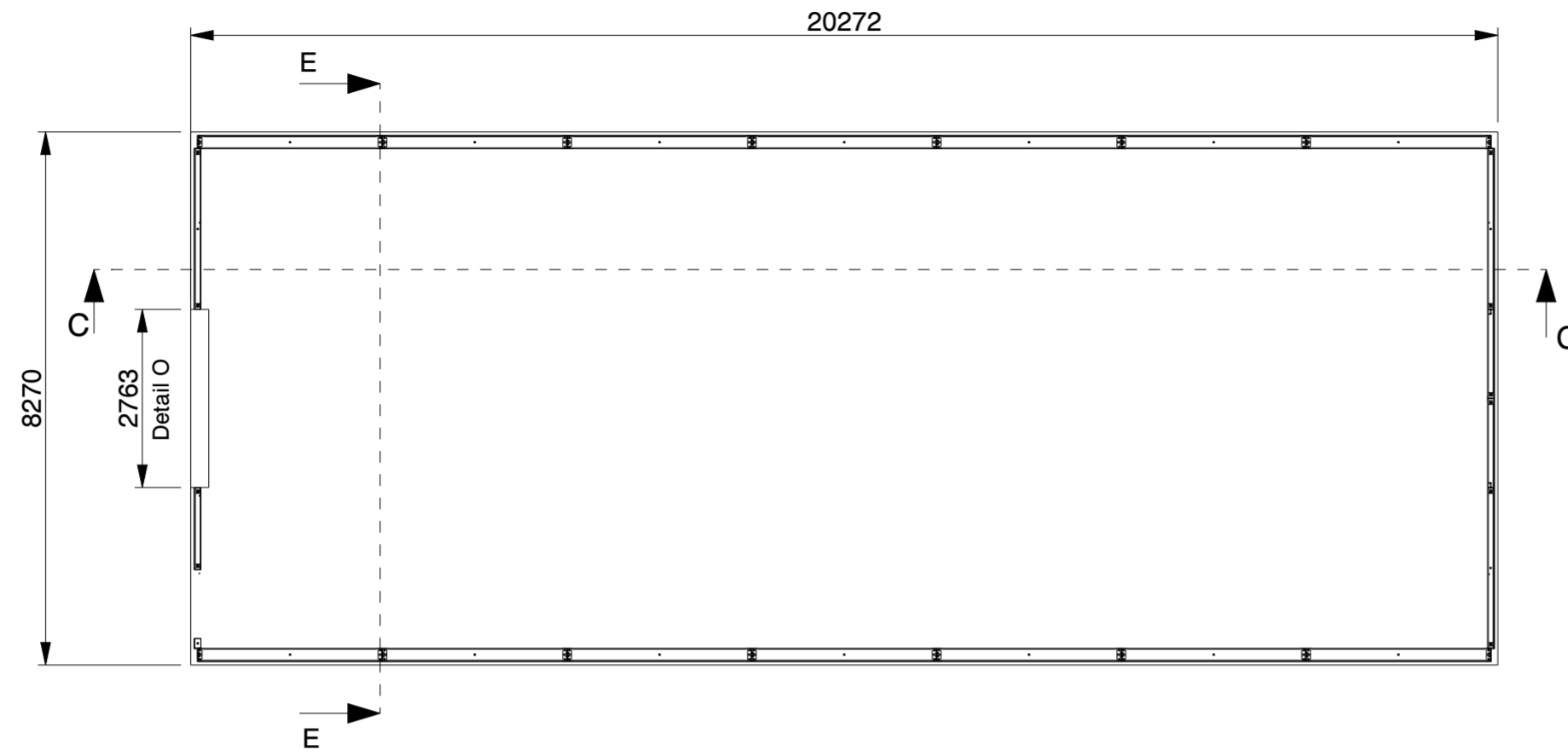

SECTION C-C

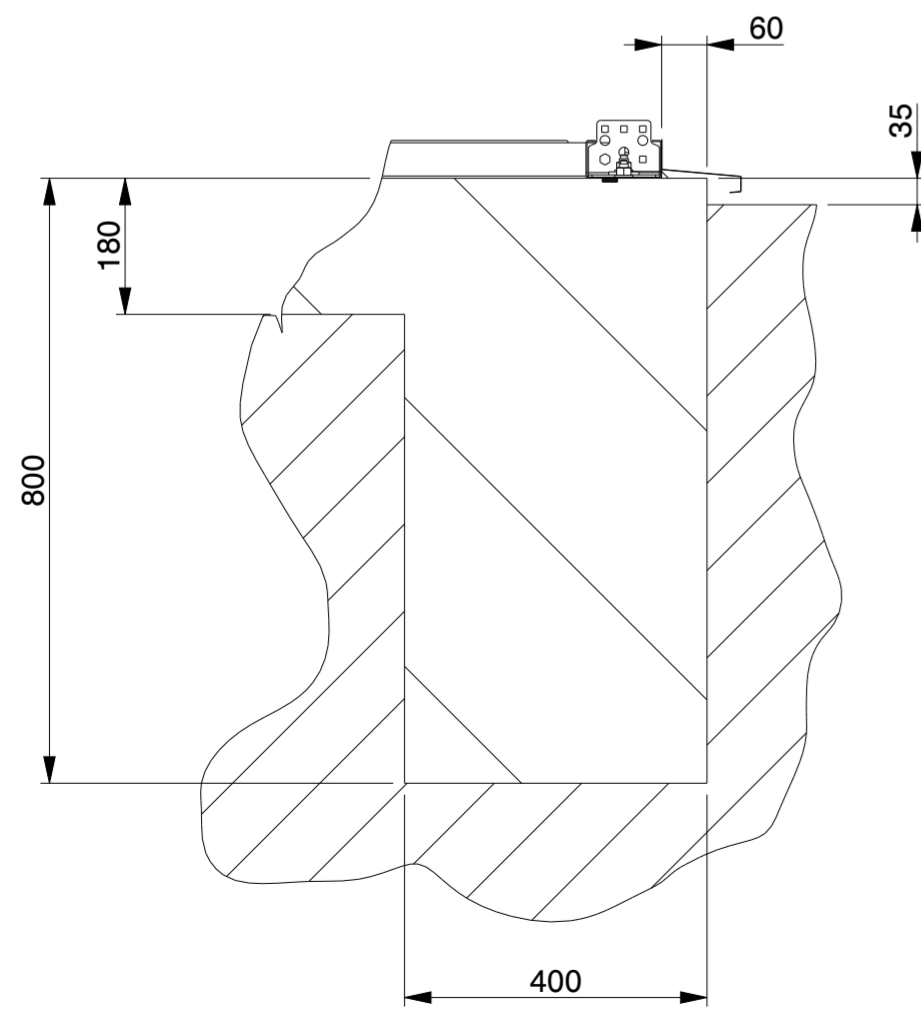

SECTION C-C  
SCALE 1:10

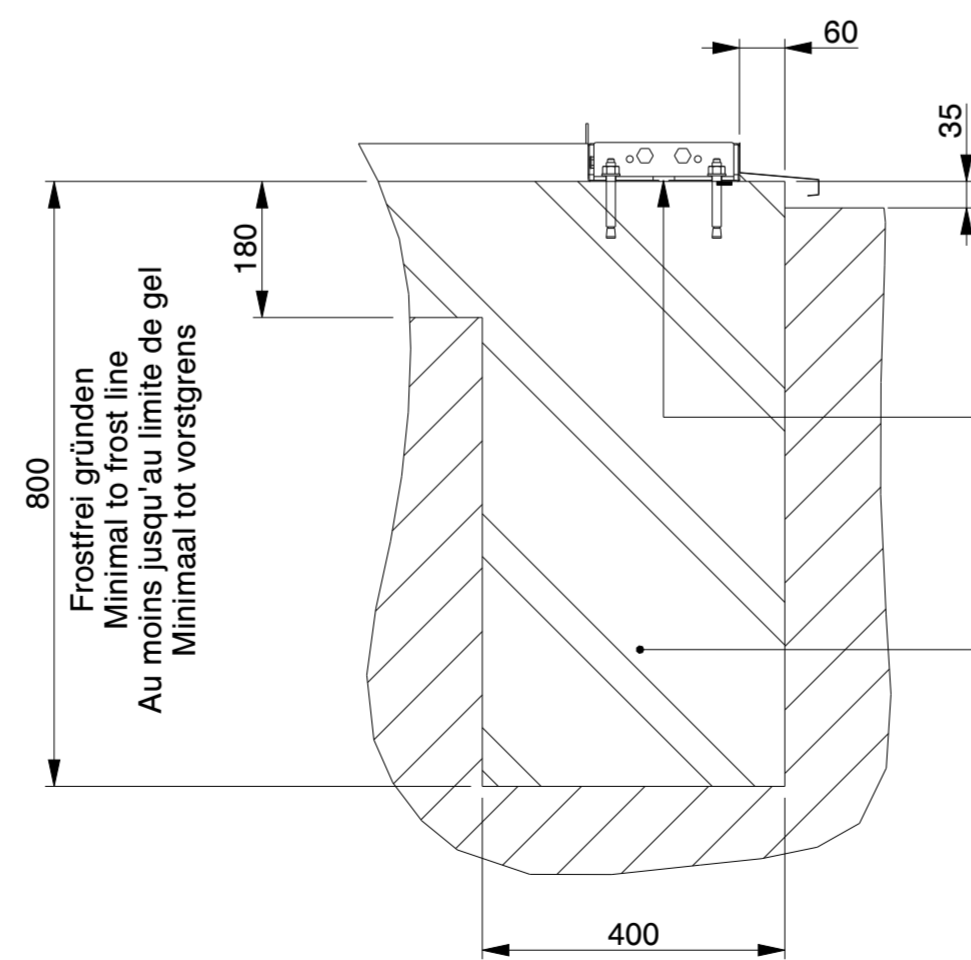

SECTION E-E  
SCALE 1:10

Butyl tape / Tixopalte sealing  
Butylband / Tixopalte abdichtung  
Ruban en butyle / joint en Tixopalte  
Butylband / Tixopalte afdichting

Bewehrungsstahl wie in der Statik angegeben  
Reinforcement bar as indicated in the  
structural calculation  
Armature de béton comme indique dans  
le calcul de construction  
betonstaal volgens de statische berekening

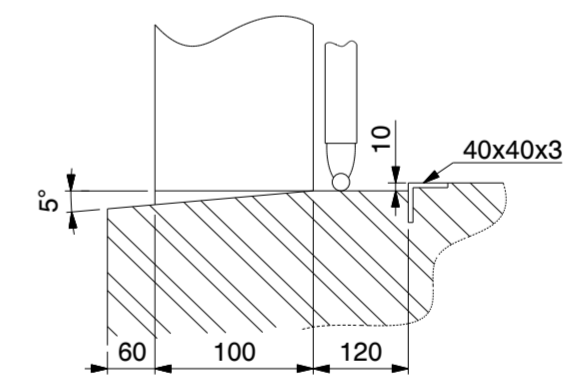

DETAIL O  
(NOT TO SCALE)

**Genehmigung / Approval / Goedkeuring**

Kundenname: Client name: Klantnaam:		Firmenstempel: Company stamp: Firmastempel:
Datum: Date: Datum:		
Unterschrift: Signature: Handtekening:		

<b>KROFTMAN</b>	LASERCUT ACCORDING: EN-ISO 9013-5-4-1		MATERIAL: See List	
	MATERIAL CERTIFICATE: 3.1 (OR 2.2 WHEN S235JR)		TREATMENT: -	
	GALVANIZING ACCORDING: EN ISO 1461		STATUS: Released	
	BEND RADIUS UNLESS DEFINED R <sub>i</sub> =1			
TOLERANCES UNLESS OTHERWISE SPECIFIED:				
GENERAL ROUGHNESS R <sub>a</sub> ✓	DIMENSION: ± 10	ANGLE: ± °	MODEL NUMBER LCA00150	REVISION: 0
DESCRIPTION: <b>Storage Building H8-33</b>				
SCALE: 1:100	UNITS: mm	PROJECTION: [Symbol]	MODIFIED ON: 08-09-2023	APPROVED ON: 08-09-2023
			MODIFIED BY: AVA	APPROVED BY: BVB
			MASS: 4968,5 kg	Sheet 3 of 4 Size: A2

© KROFTMAN STRUCTURES B.V. Duplication and copying without written permission of the owner is prohibited

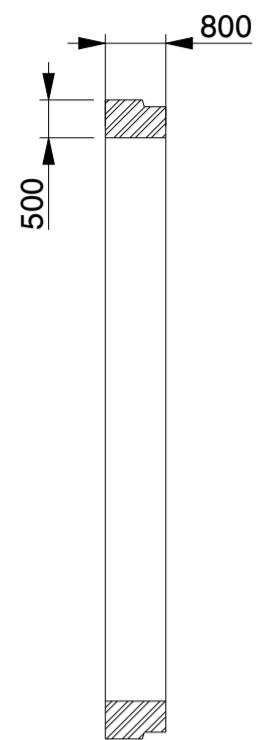

SECTION D-D

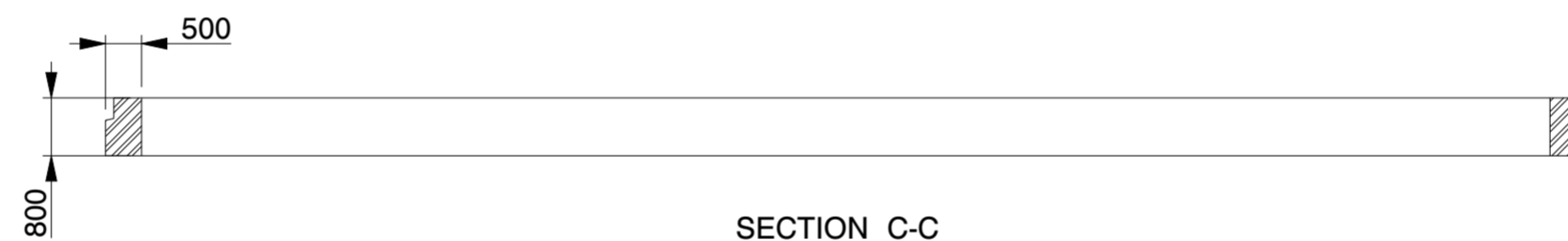
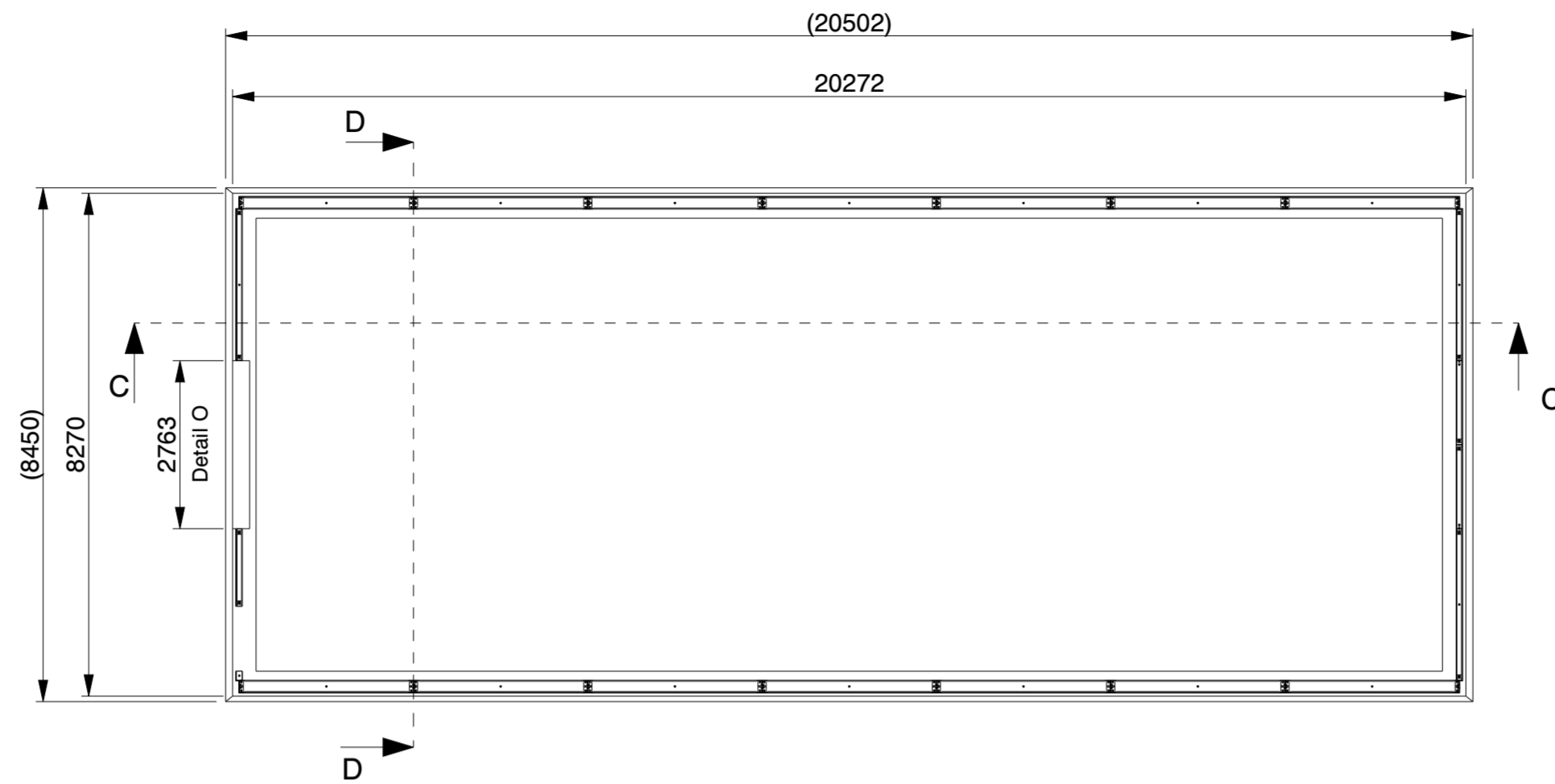

SECTION C-C

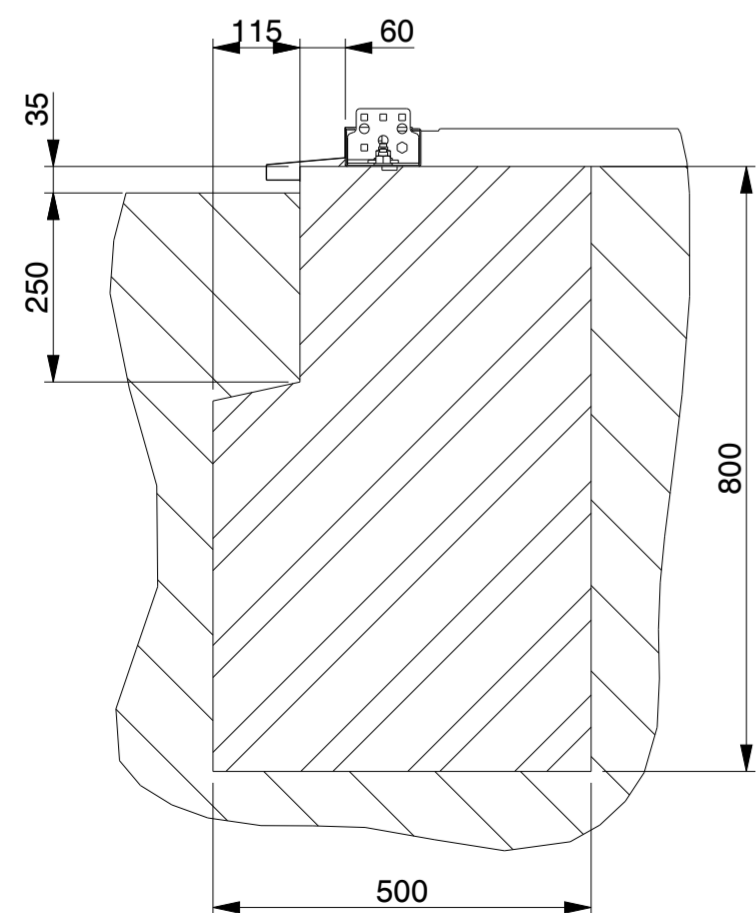

SECTION C-C  
SCALE 1:10

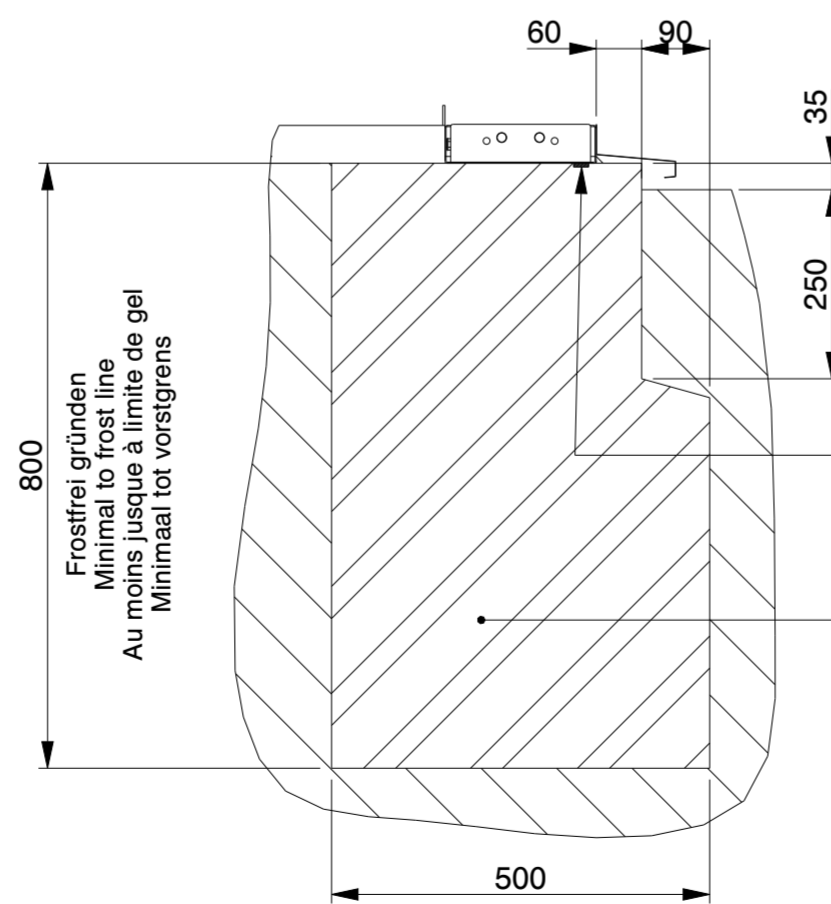

SECTION D-D  
SCALE 1:10

Butyl tape / Tixophalte sealing  
Butylband / Tixophalte abdichtung  
Ruban en butyle / joint en Tixophalte  
Butylband / Tixophalte afdichting

Bewehringsstahl wie in der Statik angegeben  
Reinforcement bar as indicated in the  
structural calculation  
Armature de béton comme indique dans  
le calcul de construction  
betonstaal volgens de statische berekening

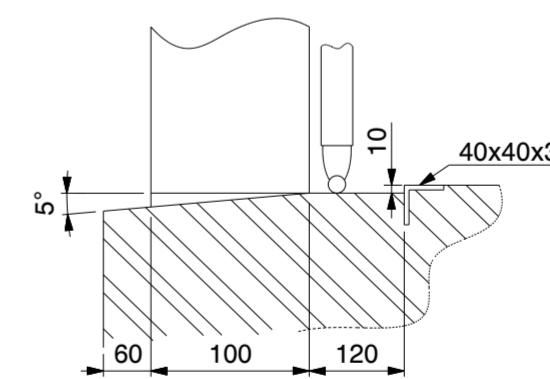

DETAIL O  
(NOT TO SCALE)

**Genehmigung / Approval / Goedkeuring**

Kundenname: Client name: Klantnaam:		Firmenstempel: Company stamp: Firmastempel:
Datum: Date: Datum:		
Unterschrift: Signature: Handtekening:		

<b>KROFTMAN</b>	LASERCUT ACCORDING: EN-ISO 9013-5-4-1		MATERIAL: See List	
	MATERIAL CERTIFICATE: 3.1 (OR 2.2 WHEN S235JR)		TREATMENT: -	
	GALVANIZING ACCORDING: EN ISO 1461		STATUS: Released	
	BEND RADIUS UNLESS DEFINED R <sub>i</sub> =1			
TOLERANCES UNLESS OTHERWISE SPECIFIED:				
GENERAL ROUGHNESS R <sub>a</sub> ✓	DIMENSION: ± 10	ANGLE: ± °	MODEL NUMBER LCA00150	REVISION: 0
DESCRIPTION: Storage Building H8-33				
SCALE: 1:100	UNITS: mm	PROJECTION: [Symbol]	MODIFIED ON: 08-09-2023	APPROVED ON: 08-09-2023
			MODIFIED BY: AVA	APPROVED BY: BVB
			MASS: 4968,5 kg	Sheet 4 of 4 Size: A2

© KROFTMAN STRUCTURES B.V. Duplication and copying without written permission of the owner is prohibited