

Genehmigung / Approval / Goedkeuring

Kundenname:
Client name:
Klantnaam:

Datum:
Date:
Datum:

Unterschrift:
Signature:
Handtekening:

Firmenstempel:
Company stamp:
Firmastempel:

LASERCUT ACCORDING: EN-ISO 9013-5-4-1		MATERIAL: See List	
MATERIAL CERTIFICATE: 3.1 (OR 2.2 WHEN S235JR)		TREATMENT:	
GALVANIZING ACCORDING: EN ISO 1461		STATUS: Released	
BEND RADIUS UNLESS DEFINED R _i =t		REVISION: 0	
TOLERANCES UNLESS OTHERWISE SPECIFIED:		MODEL NUMBER LCA00150	
GENERAL ROUGHNESS R _a ✓	DIMENSION: ± 10	ANGLE: ± °	REVISION: 0
DESCRIPTION: Storage Building H8-33			
SCALE: 1:100	UNITS: mm	PROJECTION: FIRST ANGLE	MODIFIED ON: 08-09-2023 APPROVED ON: 08-09-2023
MODIFIED BY: AVA		APPROVED BY: BVB	
MASS: 11366,5 kg		Sheet 1 of 4 Size: A2	
© KROFTMAN STRUCTURES B.V. Duplication and copying without written permission of the owner is prohibited			

Sky lights
Transparante Dachplatten
Lichtpanelen

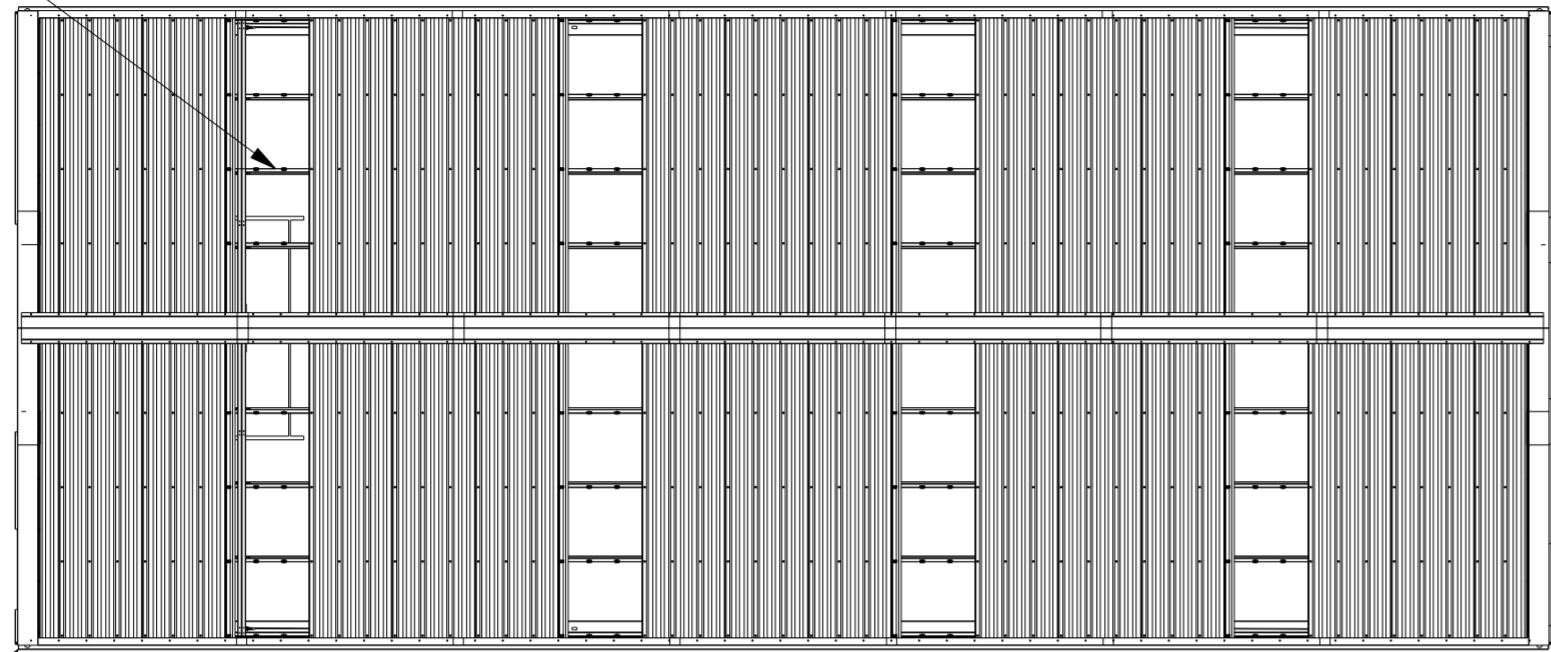

Optional Rain gutter
Optional Regenrinne
Optionnel Gouttière
Optioneel Dakgoot

0
118

20113

C100/50/13 t = 1.5mm
S320GD Z275

C200 + /50/15 t = 1.5mm
S390GD Z275

C200/50/15 t = 1.5mm
S320GD Z275

C200/50/15 t = 1.5mm
S320GD Z275

50

2865

20152

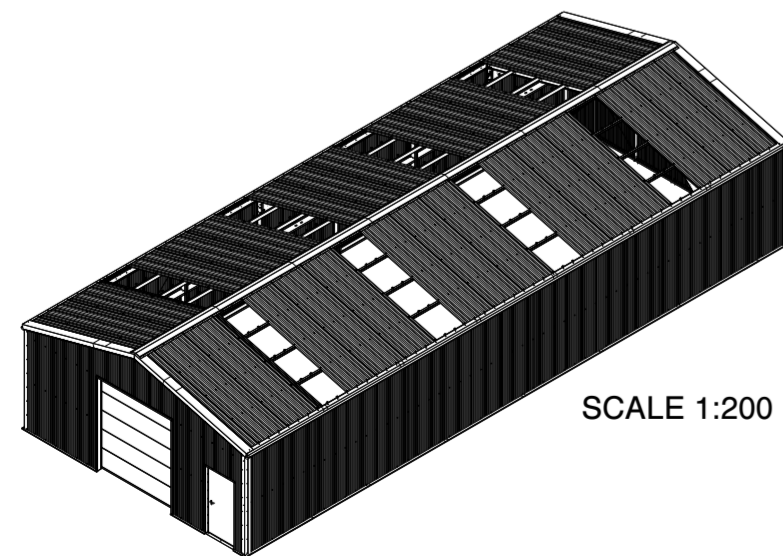

SCALE 1:200

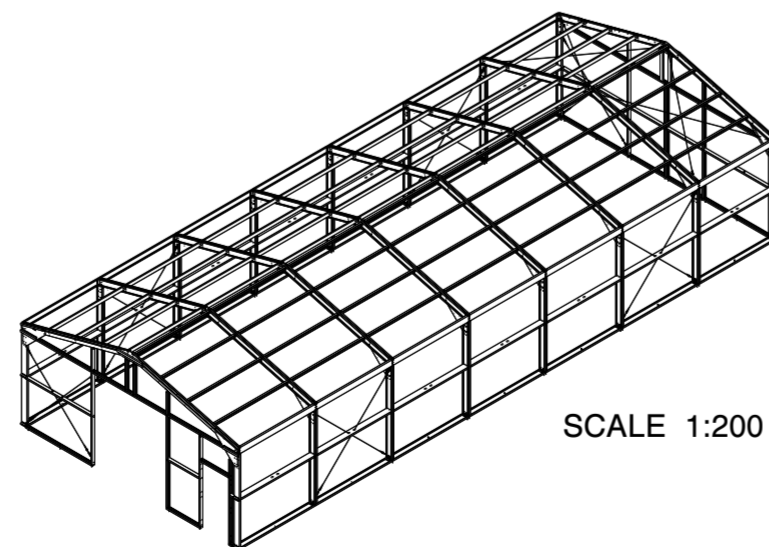

SCALE 1:200

Genehmigung / Approval / Goedkeuring

Kundenname:
Client name:
Klantnaam:

Firmenstempel:
Company stamp:
Firmastempel:

Datum:
Date:
Datum:

Unterschrift:
Signature:
Handtekening:

SANDWICH DACHPLATTE	SANDWICH ROOF PANEL	PANNEAU SANDWICH DE TOIT
POLYESTERBESCHICHTUNG	POLYESTER COATING	REVÊTEMENT POLYESTER
0.4MM STAHL (INNEN)	0.4MM STEEL (INSIDE)	0.4MM MÉTAL (INTERNE)
40/70MM PIR DÄMMSTOFF	40/70MM PIR INSULANT	40/70MM PIR ISOLANT
0.5MM STAHL (AUSSEN)	0.5MM STEEL (OUTSIDE)	0.5MM MÉTAL (EXTERNE)
POLYESTERBESCHICHTUNG	POLYESTER COATING	REVÊTEMENT POLYESTER

SANDWICHPLATTE WAND	SANDWICH WALL PANEL	PANNEAU SANDWICH PAROI
POLYESTERBESCHICHTUNG	POLYESTER COATING	REVÊTEMENT POLYESTER
0.4MM STAHL (INNEN)	0.4MM STEEL (INSIDE)	0.4MM MÉTAL (INTERNE)
40MM PIR DÄMMSTOFF	40MM PIR INSULANT	40MM PIR ISOLANT
0.5MM STAHL (AUSSEN)	0.5MM STEEL (OUTSIDE)	0.5MM MÉTAL (EXTERNE)
POLYESTERBESCHICHTUNG	POLYESTER COATING	REVÊTEMENT POLYESTER

KROFTMAN	LASERCUT ACCORDING: EN-ISO 9013-5-4-1		MATERIAL: See List	
	MATERIAL CERTIFICATE: 3.1 (OR 2.2 WHEN S235JR)		TREATMENT: -	
	GALVANIZING ACCORDING: EN ISO 1461		STATUS: Released	
	BEND RADIUS UNLESS DEFINED R _i =1		REVISION: 0	
TOLERANCES UNLESS OTHERWISE SPECIFIED:				
GENERAL ROUGHNESS Ra ✓	DIMENSION: ± 10	ANGLE: ± °	MODEL NUMBER LCA00150	
DESCRIPTION: Storage Building H8-33				
SCALE: 1:100	UNITS: mm	PROJECTION: 	MODIFIED ON: 08-09-2023	APPROVED ON: 08-09-2023
			MODIFIED BY: AVA	APPROVED BY: BVB
			MASS: 11366,5 kg	Sheet 2 of 4
				Size: A2

© KROFTMAN STRUCTURES B.V. Duplication and copying without written permission of the owner is prohibited



SECTION E-E

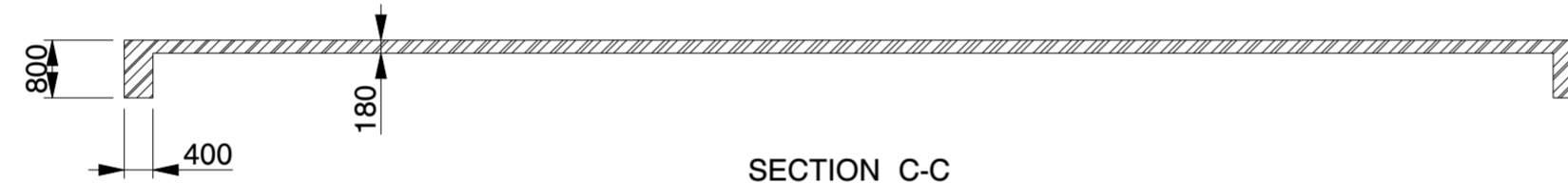
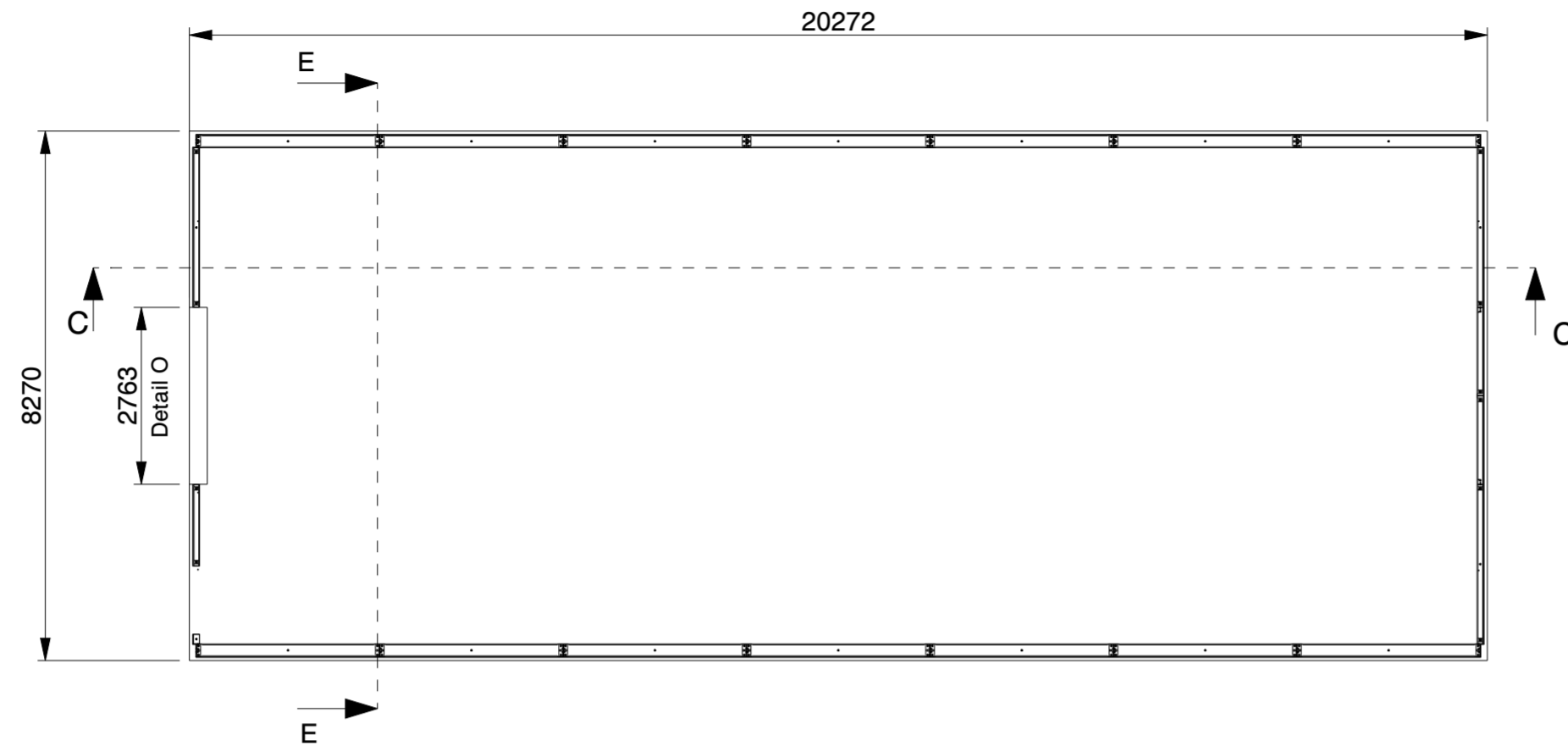

SECTION C-C

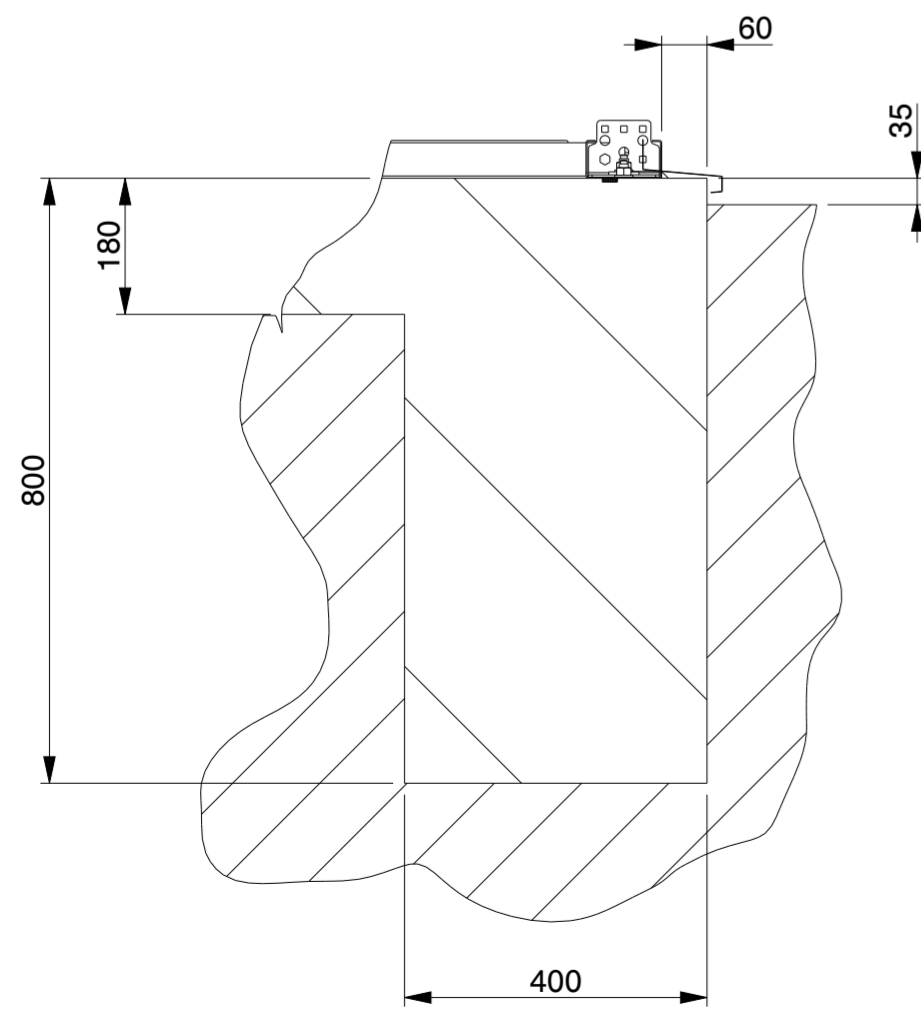

SECTION C-C
SCALE 1:10

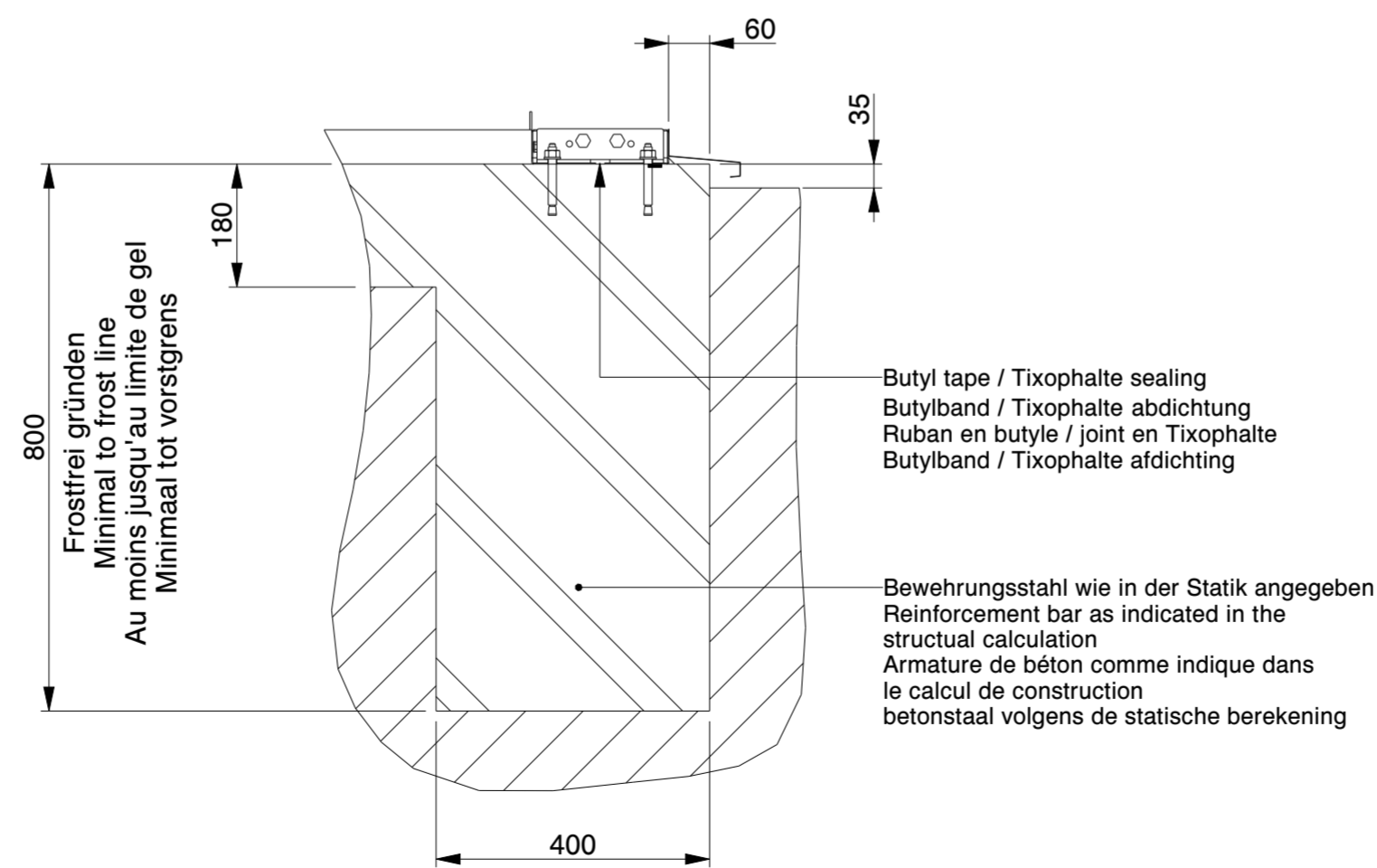

SECTION E-E
SCALE 1:10

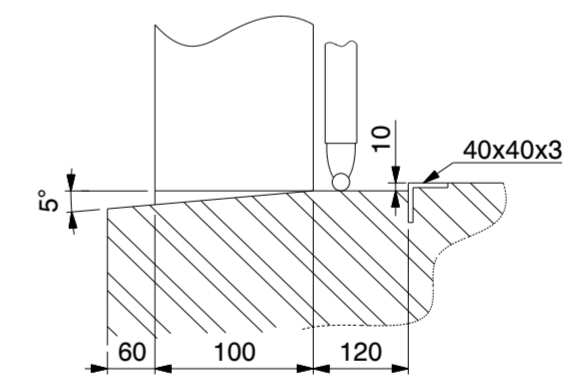

DETAIL O
(NOT TO SCALE)

Genehmigung / Approval / Goedkeuring

Kundenname: Client name: Klantnaam:		Firmenstempel: Company stamp: Firmastempel:
Datum: Date: Datum:		
Unterschrift: Signature: Handtekening:		

KROFTMAN	LASERCUT ACCORDING: EN-ISO 9013-5-4-1		MATERIAL: See List	
	MATERIAL CERTIFICATE: 3.1 (OR 2.2 WHEN S235JR)		TREATMENT: -	
	GALVANIZING ACCORDING: EN ISO 1461		STATUS: Released	
	BEND RADIUS UNLESS DEFINED R _i =1			
TOLERANCES UNLESS OTHERWISE SPECIFIED:				
GENERAL ROUGHNESS R _a ✓	DIMENSION: ± 10	ANGLE: ± °	MODEL NUMBER LCA00150	REVISION: 0
DESCRIPTION: Storage Building H8-33				
SCALE: 1:100	UNITS: mm	PROJECTION: [Symbol]	MODIFIED ON: 08-09-2023	APPROVED ON: 08-09-2023
			MODIFIED BY: AVA	APPROVED BY: BVB
			MASS: 11366,5 kg	Sheet 3 of 4
				Size: A2

© KROFTMAN STRUCTURES B.V. Duplication and copying without written permission of the owner is prohibited

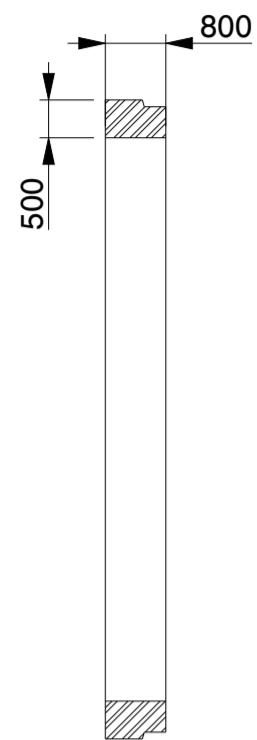

SECTION D-D

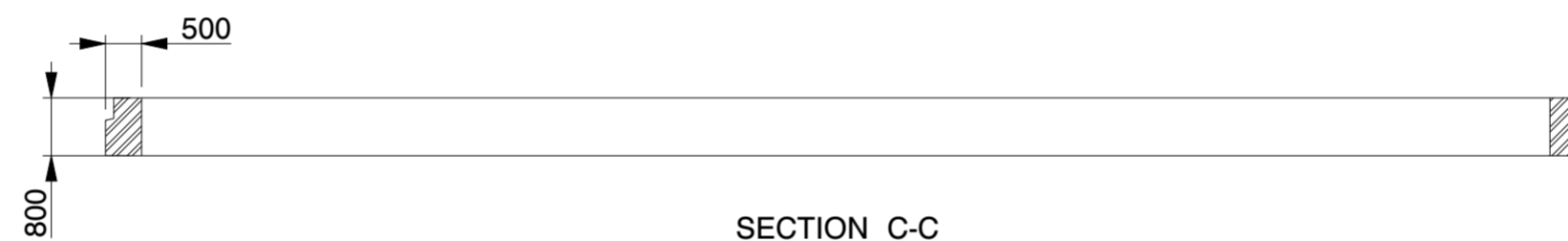
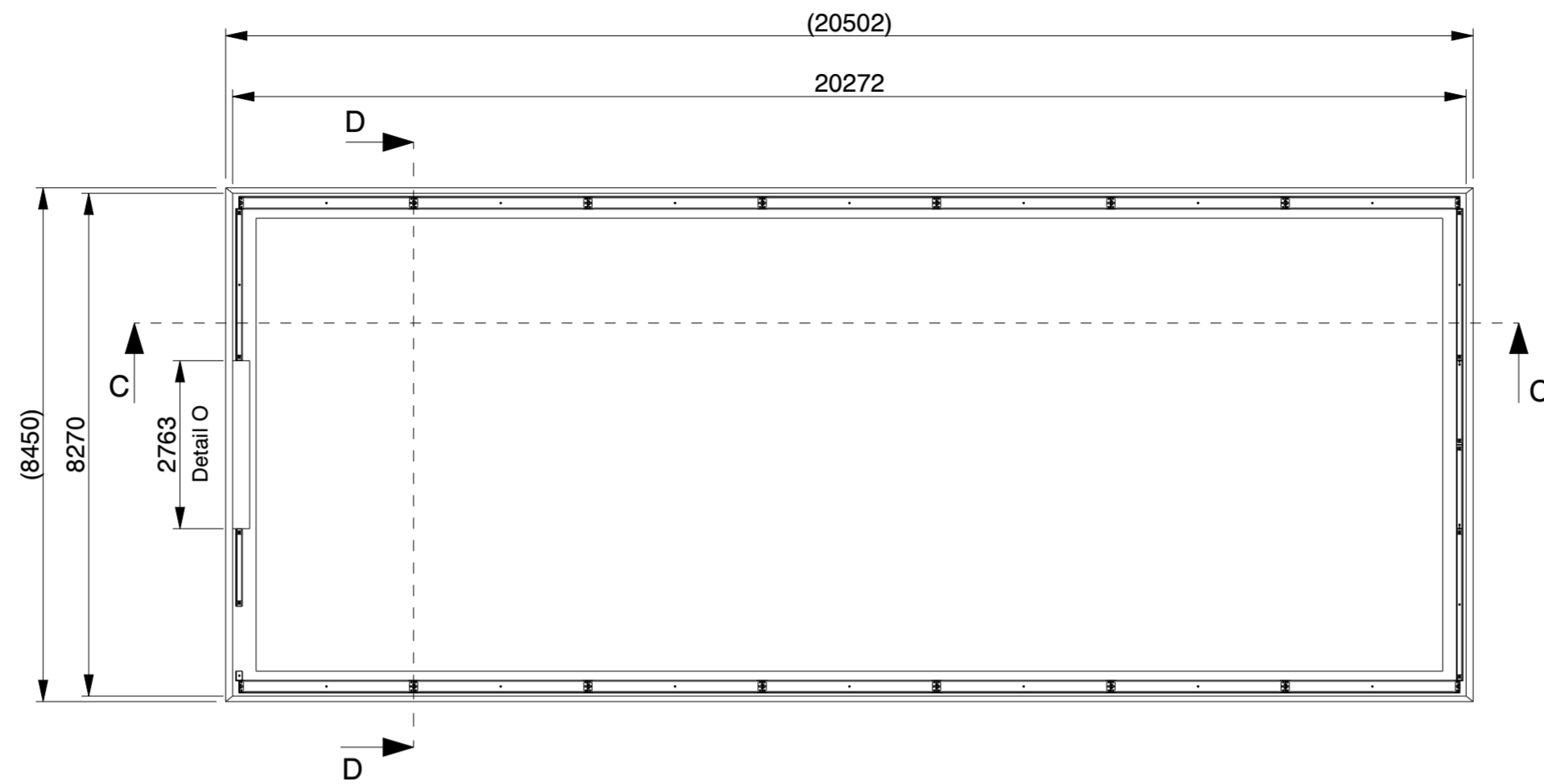

SECTION C-C

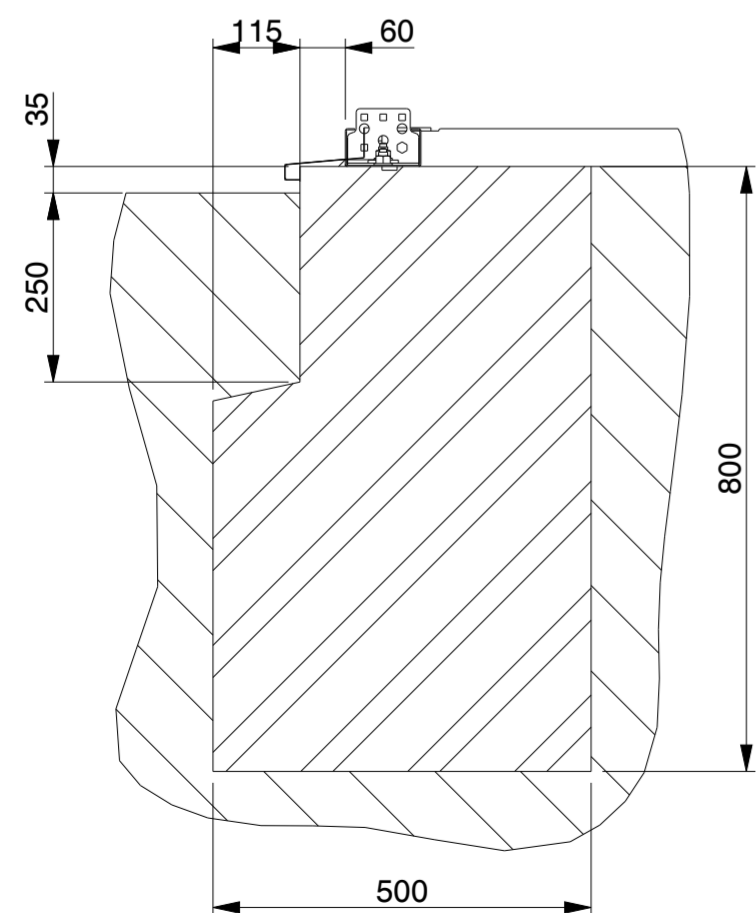

SECTION C-C
SCALE 1:10

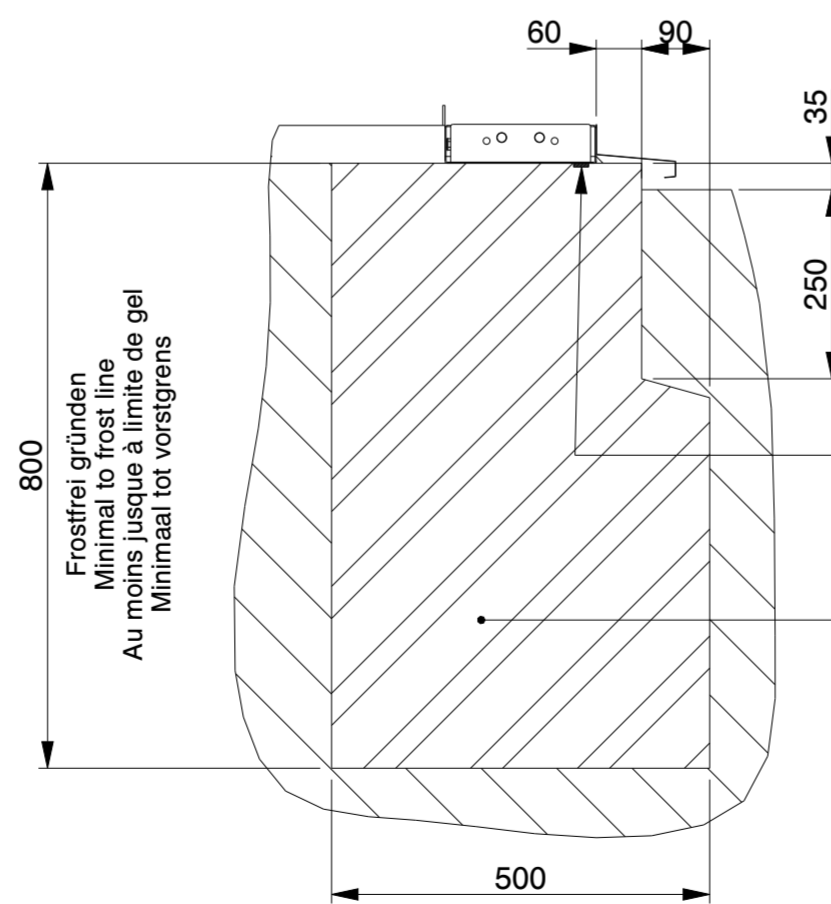

SECTION D-D
SCALE 1:10

Butyl tape / Tixophalte sealing
Butylband / Tixophalte abdichtung
Ruban en butyle / joint en Tixophalte
Butylband / Tixophalte afdichting

Bewehringsstaal wie in der Statik angegeben
Reinforcement bar as indicated in the
structural calculation
Armature de béton comme indique dans
le calcul de construction
betonstaal volgens de statische berekening

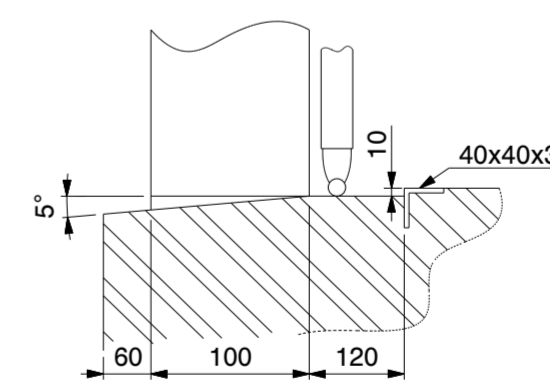

DETAIL O
(NOT TO SCALE)

Genehmigung / Approval / Goedkeuring

Kundenname: Client name: Klantnaam:		Firmenstempel: Company stamp: Firmastempel:
Datum: Date: Datum:		
Unterschrift: Signature: Handtekening:		

KROFTMAN	LASERCUT ACCORDING: EN-ISO 9013-5-4-1		MATERIAL: See List	
	MATERIAL CERTIFICATE: 3.1 (OR 2.2 WHEN S235JR)		TREATMENT: -	
	GALVANIZING ACCORDING: EN ISO 1461		STATUS: Released	
	BEND RADIUS UNLESS DEFINED R _i =1			
TOLERANCES UNLESS OTHERWISE SPECIFIED:				
GENERAL ROUGHNESS R _a ✓	DIMENSION: ± 10	ANGLE: ± °	MODEL NUMBER LCA00150	REVISION: 0
DESCRIPTION: Storage Building H8-33				
SCALE: 1:100	UNITS: mm	PROJECTION: [Symbol]	MODIFIED ON: 08-09-2023	APPROVED ON: 08-09-2023
			MODIFIED BY: AVA	APPROVED BY: BVB
			MASS: 11366,5 kg	Sheet 4 of 4 Size: A2

© KROFTMAN STRUCTURES B.V. Duplication and copying without written permission of the owner is prohibited