

Front wall structure only

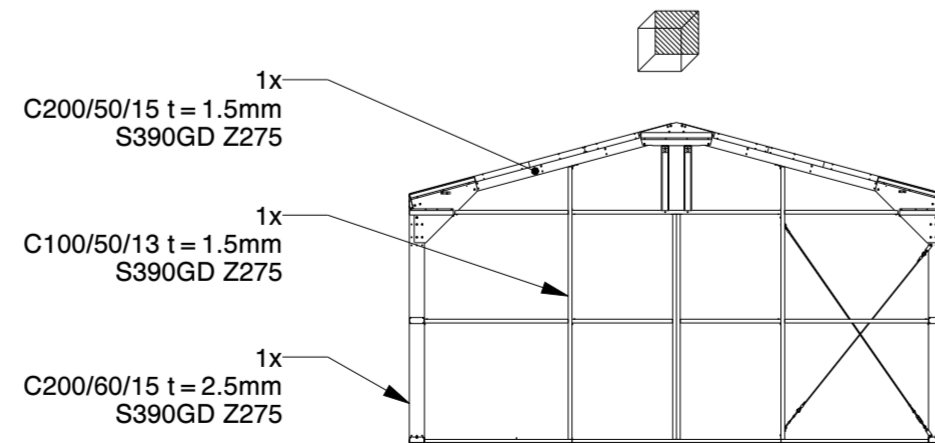

Back wall structure only

**Genehmigung / Approval / Goedkeuring**

Kundenname: Client name: Klantnaam:		Firmenstempel: Company stamp: Firmastempel:	
Datum: Date: Datum:			
Unterschrift: Signature: Handtekening:			

<b>KROFTMAN</b>	LASERCUT ACCORDING: EN-ISO 9013-5-4-1		MATERIAL: See List	
	MATERIAL CERTIFICATE: 3.1 (OR 2.2 WHEN S235JR)		TREATMENT:	
	GALVANIZING ACCORDING: EN ISO 1461		STATUS: Released	
	BEND RADIUS UNLESS DEFINED R <sub>i</sub> =t			
GENERAL ROUGHNESS R <sub>a</sub> ✓	DIMENSION: ±	ANGLE: ±°	MODEL NUMBER <b>LCA00145</b>	REVISION: <b>0</b>
DESCRIPTION: <b>Storage Building H7-33</b>				
SCALE: 1:100	UNITS: mm	PROJECTION: [Symbol]	MODIFIED ON: 08-09-2023 MODIFIED BY: AVA MASS: 4166,5 kg	APPROVED ON: 08-09-2023 APPROVED BY: BVB Sheet 1 of 4 Size: A2
© KROFTMAN STRUCTURES B.V. Duplication and copying without written permission of the owner is prohibited				

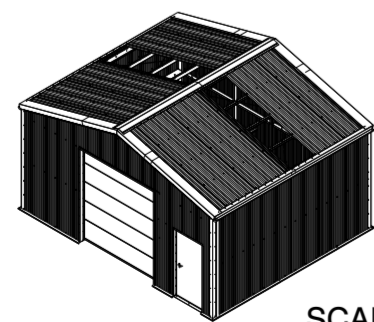
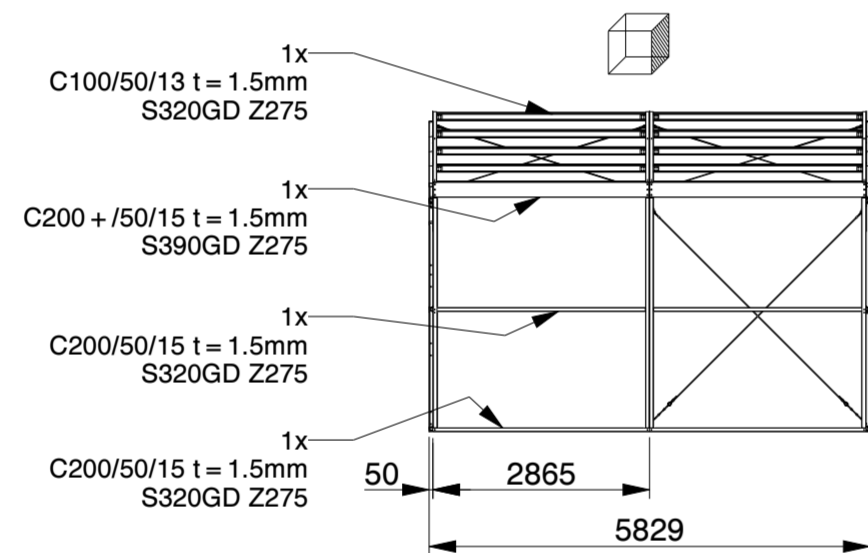
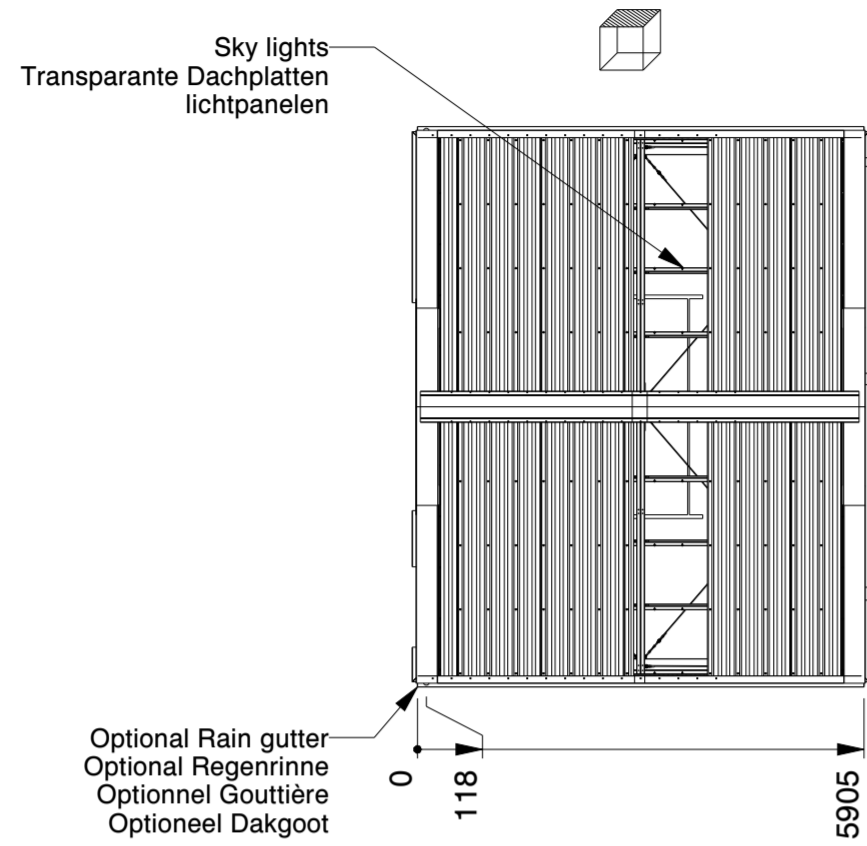

SCALE 1:200

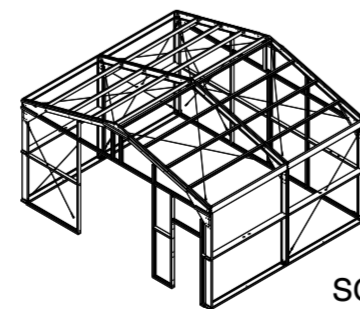

SCALE 1:200

**Genehmigung / Approval / Goedkeuring**

Kundenname: Client name: Klantnaam:		Firmenstempel: Company stamp: Firmastempel:
Datum: Date: Datum:		
Unterschrift: Signature: Handtekening:		

SANDWICH DACHPLATTE	SANDWICH ROOF PANEL	PANNEAU SANDWICH DE TOIT
POLYESTERBESCHICHTUNG	POLYESTER COATING	REVÊTEMENT POLYESTER
0.4MM STAHL (INNEN)	0.4MM STEEL (INSIDE)	0.4MM MÉTAL (INTERNE)
40/70MM PIR DÄMMSTOFF	40/70MM PIR INSULANT	40/70MM PIR ISOLANT
0.5MM STAHL (AUSSEN)	0.5MM STEEL (OUTSIDE)	0.5MM MÉTAL (EXTERNE)
POLYESTERBESCHICHTUNG	POLYESTER COATING	REVÊTEMENT POLYESTER

SANDWICHPLATTE WAND	SANDWICH WALL PANEL	PANNEAU SANDWICH PAROI
POLYESTERBESCHICHTUNG	POLYESTER COATING	REVÊTEMENT POLYESTER
0.4MM STAHL (INNEN)	0.4MM STEEL (INSIDE)	0.4MM MÉTAL (INTERNE)
40MM PIR DÄMMSTOFF	40MM PIR INSULANT	40MM PIR ISOLANT
0.5MM STAHL (AUSSEN)	0.5MM STEEL (OUTSIDE)	0.5MM MÉTAL (EXTERNE)
POLYESTERBESCHICHTUNG	POLYESTER COATING	REVÊTEMENT POLYESTER

<b>KROFTMAN</b>	LASERCUT ACCORDING: EN-ISO 9013-5-4-1		MATERIAL: See List	
	MATERIAL CERTIFICATE: 3.1 (OR 2.2 WHEN S235JR)		TREATMENT: -	
	GALVANIZING ACCORDING: EN ISO 1461		STATUS: Released	
	BEND RADIUS UNLESS DEFINED R <sub>i</sub> =t			
TOLERANCES UNLESS OTHERWISE SPECIFIED:				
GENERAL ROUGHNESS R <sub>a</sub> ✓	DIMENSION: ±	ANGLE: ±°	MODEL NUMBER <b>LCA00145</b>	REVISION: <b>0</b>
DESCRIPTION: <b>Storage Building H7-33</b>				
SCALE: 1:100	UNITS: mm	PROJECTION: 	MODIFIED ON: 08-09-2023 MODIFIED BY: AVA	APPROVED ON: 08-09-2023 APPROVED BY: BVB
			MASS: 4166,5 kg	Sheet 2 of 4 Size: A2

© KROFTMAN STRUCTURES B.V. Duplication and copying without written permission of the owner is prohibited

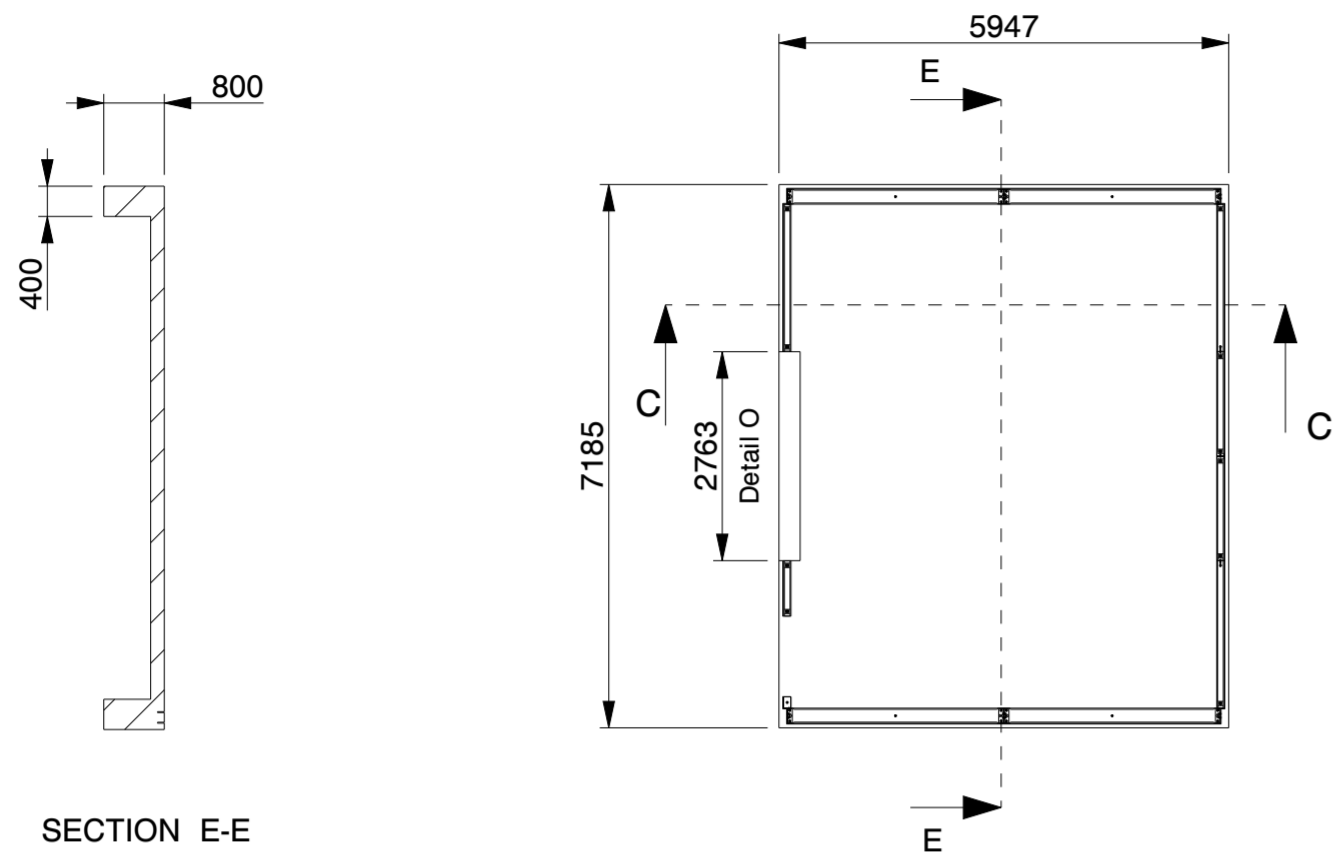

SECTION E-E

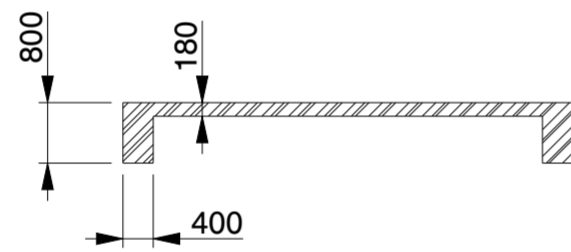

SECTION C-C

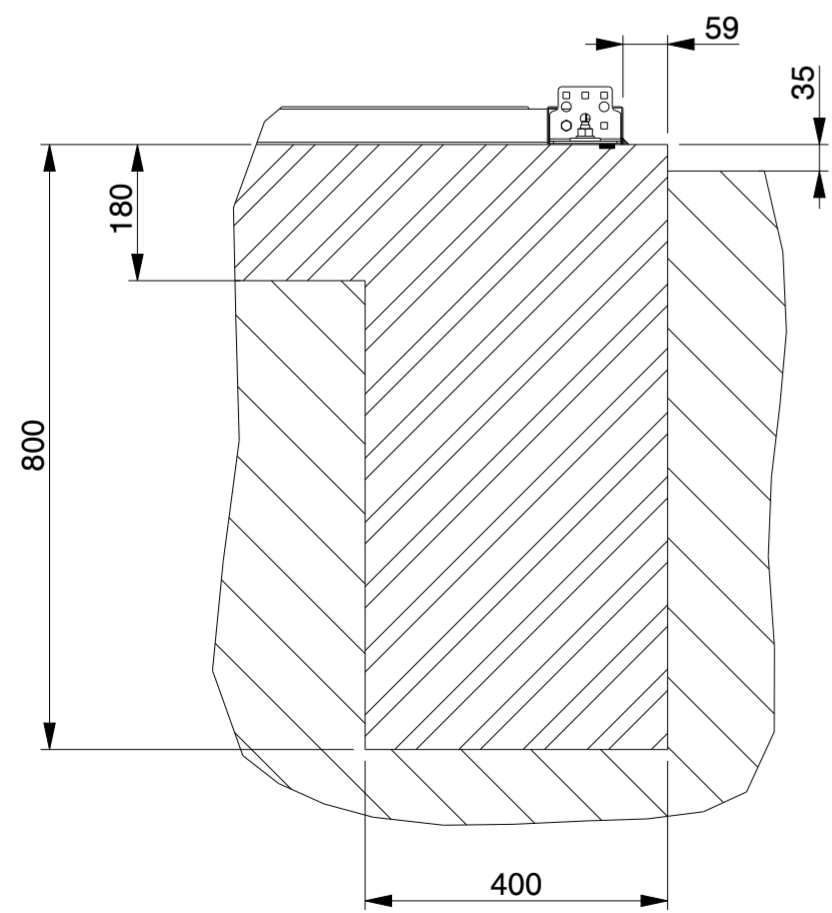

SECTION C-C  
SCALE 1:10

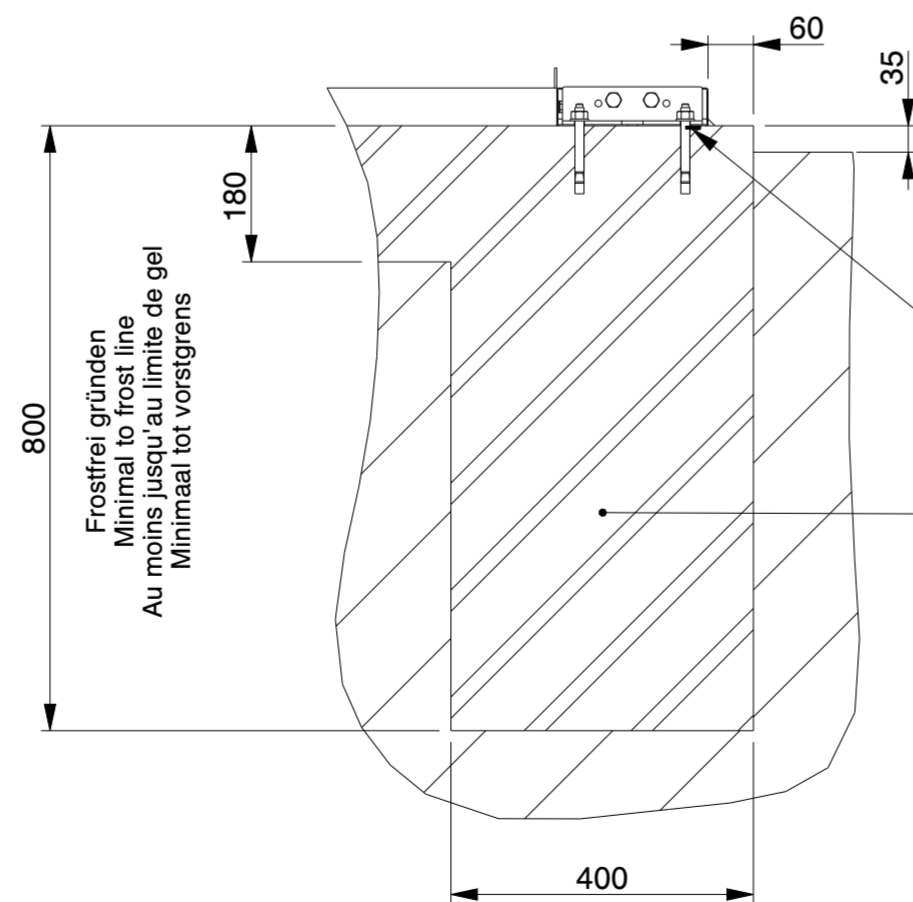

SECTION E-E  
SCALE 1:10

Frosstfrei gründen  
Minimal to frost line  
Au moins jusqu'au limite de gel  
Minimaal tot vorstgrens

Butyl tape / Tixophalte sealing option  
Butylband / Tixophalte Abdichtung Option  
Ruban en butyle / joint en Tixophalte Option  
Butylband / Tixophalte afdichting optie

Bewehrungsstahl wie in der Statik angegeben  
Reinforcement bar as indicated in the  
structural calculation  
Armature de béton comme indique dans  
le calcul de construction  
betonstaal volgens de statische berekening

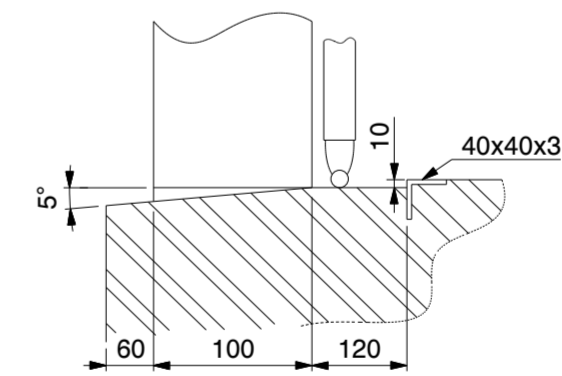

DETAIL O  
(NOT TO SCALE)

**Genehmigung / Approval / Goedkeuring**

Kundenname: Client name: Klantnaam:	Firmenstempel: Company stamp: Firmastempel:
Datum: Date: Datum:	
Unterschrift: Signature: Handtekening:	

**Betonplatte / Concrete slab / Dalle de béton**

<b>KROFTMAN</b>	LASERCUT ACCORDING: EN-ISO 9013-5-4-1		MATERIAL: See List	
	MATERIAL CERTIFICATE: 3.1 (OR 2.2 WHEN S235JR)		TREATMENT: -	
	GALVANIZING ACCORDING: EN ISO 1461		STATUS: Released	
	BEND RADIUS UNLESS DEFINED R <sub>i</sub> =1			
TOLERANCES UNLESS OTHERWISE SPECIFIED:				
GENERAL ROUGHNESS R <sub>a</sub> ✓	DIMENSION: ±	ANGLE: ±°	MODEL NUMBER LCA00145	REVISION: 0
DESCRIPTION: <b>Storage Building H7-33</b>				
SCALE: 1:100	UNITS: mm	PROJECTION: [Symbol]	MODIFIED ON: 08-09-2023	APPROVED ON: 08-09-2023
			MODIFIED BY: AVA	APPROVED BY: BVB
			MASS: 4166,5 kg	Sheet 3 of 4 Size: A2

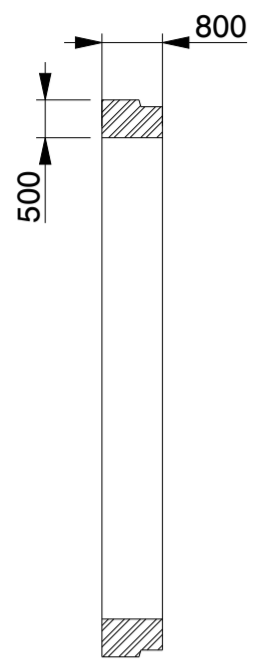

SECTION D-D

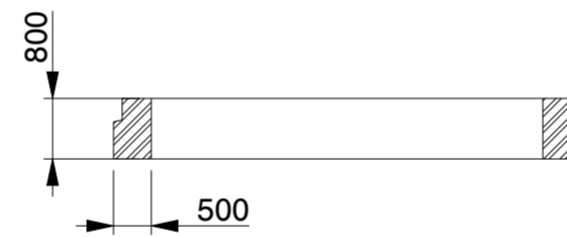
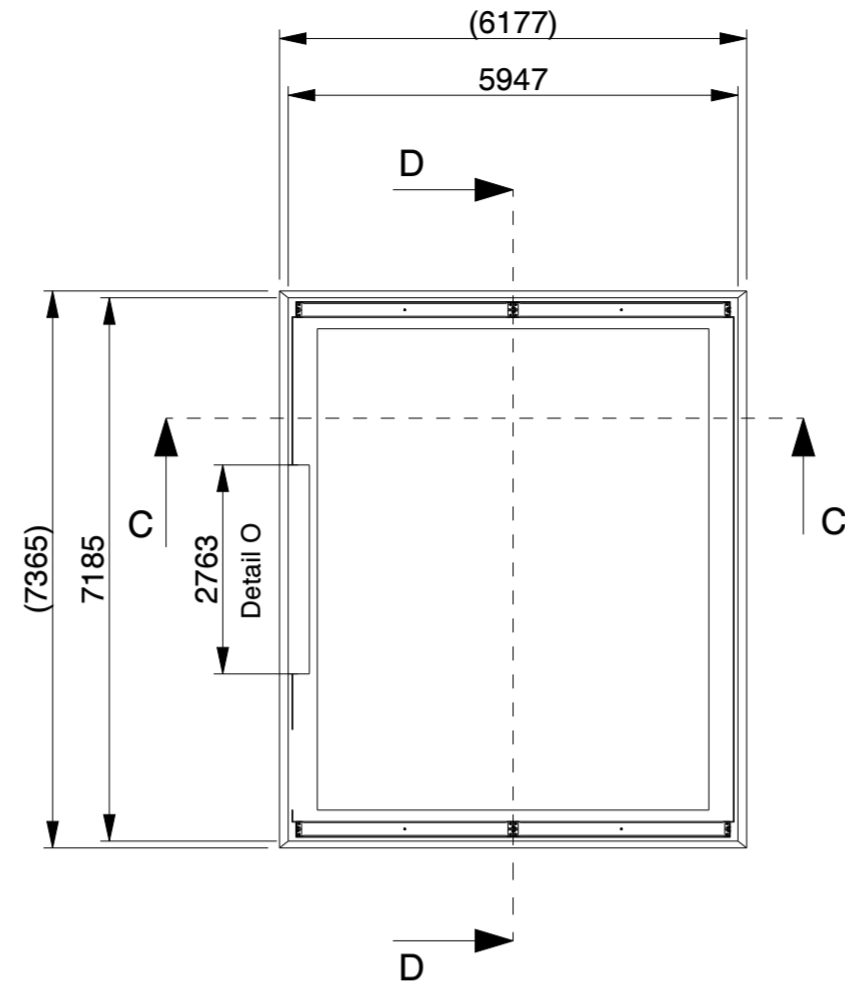

SECTION C-C

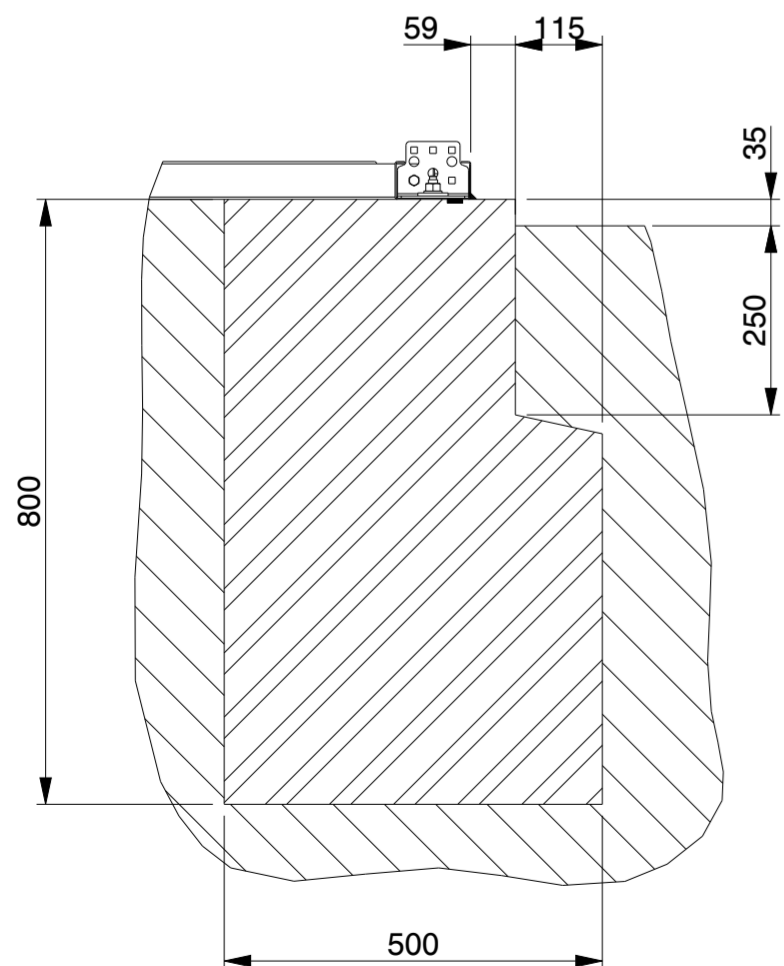

SECTION C-C  
SCALE 1:10

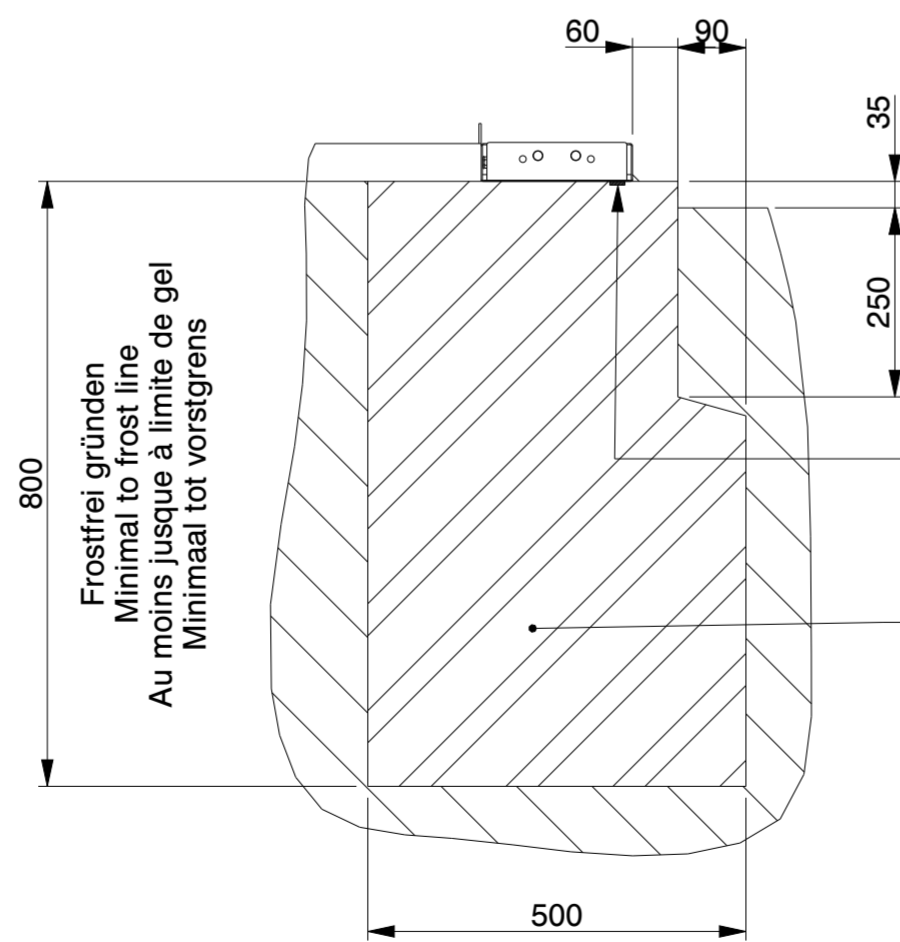

SECTION D-D  
SCALE 1:10

Butyl tape / Tixophalte sealing option  
Butylband / Tixophalte Abdichtung  
Ruban en butyle / joint en Tixophalte option  
Butylband / Tixophalte afdichting optie

Bewehrungsstahl wie in der Statik angegeben  
Concrete reinforcement as indicated in  
the structural calculation  
Armature de béton comme indique dans le clacul  
de construction  
betonbewapening zoals in de  
constructieberekening aangegeven

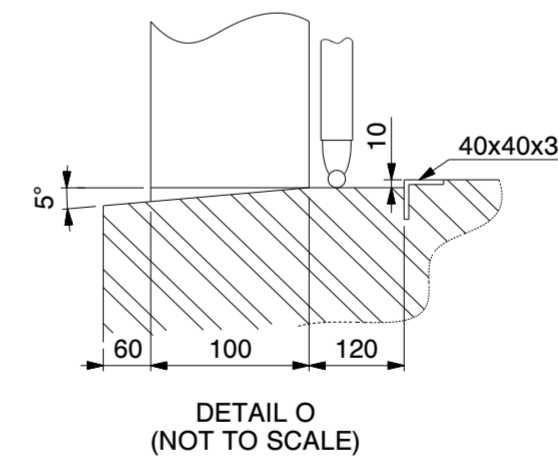

DETAIL O  
(NOT TO SCALE)

Genehmigung / Approval / Goedkeuring		
Kundenname: Client name: Klantnaam:		Firmenstempel: Company stamp: Firmastempel:
Datum: Date: Datum:		
Unterschrift: Signature: Handtekening:		

Strookfundering / Streifenfundament /  
Strip foundation / Fondation en bande

<b>KROFTMAN</b>	LASERCUT ACCORDING: EN-ISO 9013-5-4-1		MATERIAL: See List	
	MATERIAL CERTIFICATE: 3.1 (OR 2.2 WHEN S235JR)		TREATMENT: -	
	GALVANIZING ACCORDING: EN ISO 1461		STATUS: Released	
	BEND RADIUS UNLESS DEFINED R <sub>i</sub> =1			
GENERAL ROUGHNESS R <sub>a</sub> ✓	DIMENSION: ±	ANGLE: ±°	MODEL NUMBER LCA00145	REVISION: 0
DESCRIPTION: Storage Building H7-33				
SCALE: 1:100	UNITS: mm	PROJECTION: [Symbol]	MODIFIED ON: 08-09-2023	APPROVED ON: 08-09-2023
			MODIFIED BY: AVA	APPROVED BY: BVB
			MASS: 4166,5 kg	Sheet 4 of 4 Size: A2

© KROFTMAN STRUCTURES B.V. Duplication and copying without written permission of the owner is prohibited