

Genehmigung / Approval / Goedkeuring		
Kundenname: Client name: Klantnaam:		Firmenstempel: Company stamp: Firmastempel:
Datum: Date: Datum:		
Unterschrift: Signature: Handtekening:		

KROFTMAN	LASERCUT ACCORDING: EN-ISO 9013-5-4-1		MATERIAL: See List	
	MATERIAL CERTIFICATE: 3.1 (OR 2.2 WHEN S235JR)		TREATMENT:	
	GALVANIZING ACCORDING: EN ISO 1461		STATUS: Released	
	BEND RADIUS UNLESS DEFINED R _i =t			
GENERAL ROUGHNESS R _a ✓	DIMENSION: ±	ANGLE: ±°	MODEL NUMBER LCA00145	REVISION: 0
DESCRIPTION: Storage Building H7-33				
SCALE: 1:100	UNITS: mm	PROJECTION: 	MODIFIED ON: 08-09-2023 MODIFIED BY: AVA MASS: 5086,7 kg	APPROVED ON: 08-09-2023 APPROVED BY: BVB Sheet 1 of 4 Size: A2
© KROFTMAN STRUCTURES B.V. Duplication and copying without written permission of the owner is prohibited				

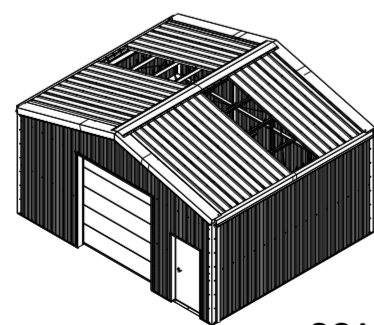

SCALE 1:200

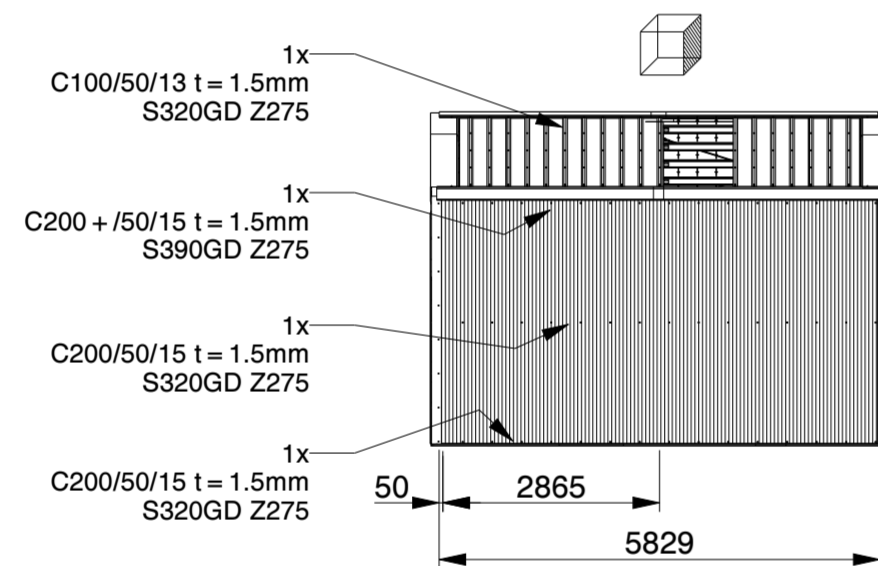
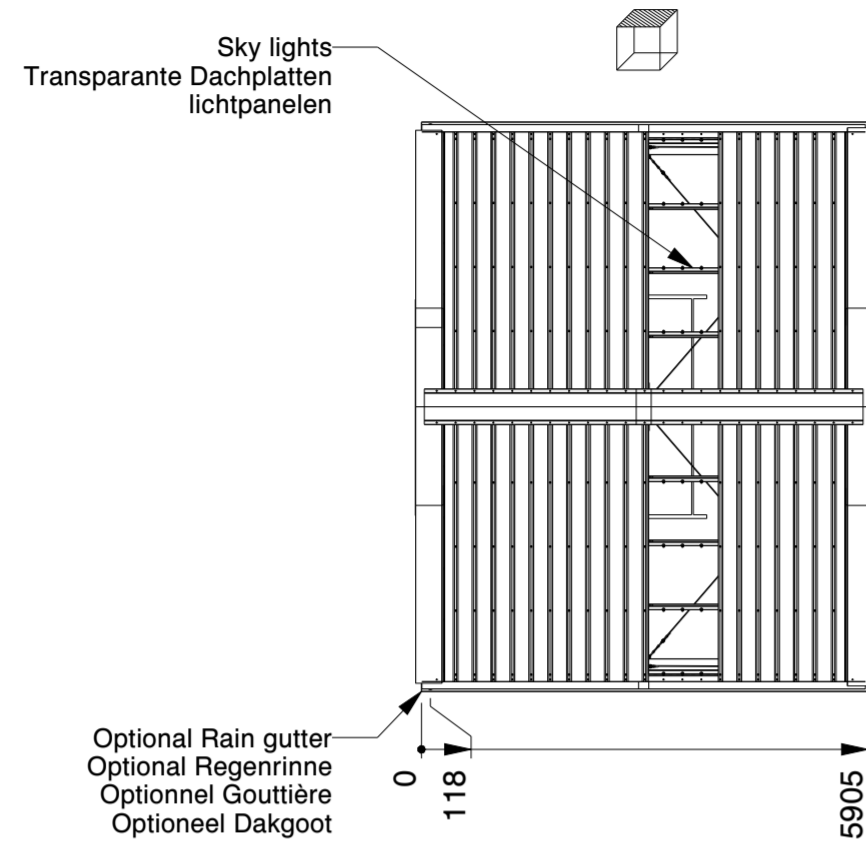
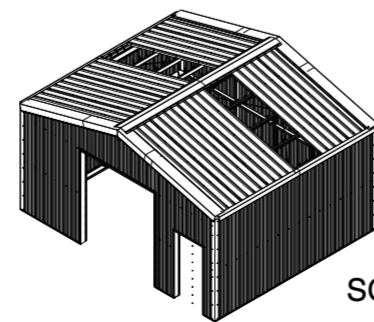

SCALE 1:200

Genehmigung / Approval / Goedkeuring

Kundenname: Client name: Klantnaam:		Firmenstempel: Company stamp: Firmastempel:
Datum: Date: Datum:		
Unterschrift: Signature: Handtekening:		

SANDWICH DACHPLATTE	SANDWICH ROOF PANEL	PANNEAU SANDWICH DE TOIT
POLYESTERBESCHICHTUNG	POLYESTER COATING	REVÊTEMENT POLYESTER
0.4MM STAHL (INNEN)	0.4MM STEEL (INSIDE)	0.4MM MÉTAL (INTERNE)
100/133MM PIR DÄMMSTOFF	100/133MM PIR INSULANT	100/133MM PIR ISOLANT
0.5MM STAHL (AUSSEN)	0.5MM STEEL (OUTSIDE)	0.5MM MÉTAL (EXTERNE)
POLYESTERBESCHICHTUNG	POLYESTER COATING	REVÊTEMENT POLYESTER

SANDWICHPLATTE WAND	SANDWICH WALL PANEL	PANNEAU SANDWICH PAROI
POLYESTERBESCHICHTUNG	POLYESTER COATING	REVÊTEMENT POLYESTER
0.4MM STAHL (INNEN)	0.4MM STEEL (INSIDE)	0.4MM MÉTAL (INTERNE)
100MM PIR DÄMMSTOFF	100MM PIR INSULANT	100MM PIR ISOLANT
0.5MM STAHL (AUSSEN)	0.5MM STEEL (OUTSIDE)	0.5MM MÉTAL (EXTERNE)
POLYESTERBESCHICHTUNG	POLYESTER COATING	REVÊTEMENT POLYESTER

KROFTMAN	LASERCUT ACCORDING: EN-ISO 9013-5-4-1		MATERIAL: See List	
	MATERIAL CERTIFICATE: 3.1 (OR 2.2 WHEN S235JR)		TREATMENT: -	
	GALVANIZING ACCORDING: EN ISO 1461		STATUS: Released	
	BEND RADIUS UNLESS DEFINED R _i =t			
TOLERANCES UNLESS OTHERWISE SPECIFIED:				
GENERAL ROUGHNESS R _a ✓	DIMENSION: ±	ANGLE: ±°	MODEL NUMBER LCA00145	REVISION: 0
DESCRIPTION: Storage Building H7-33				
SCALE: 1:100	UNITS: mm	PROJECTION: 	MODIFIED ON: 08-09-2023 MODIFIED BY: AVA	APPROVED ON: 08-09-2023 APPROVED BY: BVB
		MASS: 5086,7 kg	Sheet 2 of 4	Size: A2

© KROFTMAN STRUCTURES B.V. Duplication and copying without written permission of the owner is prohibited

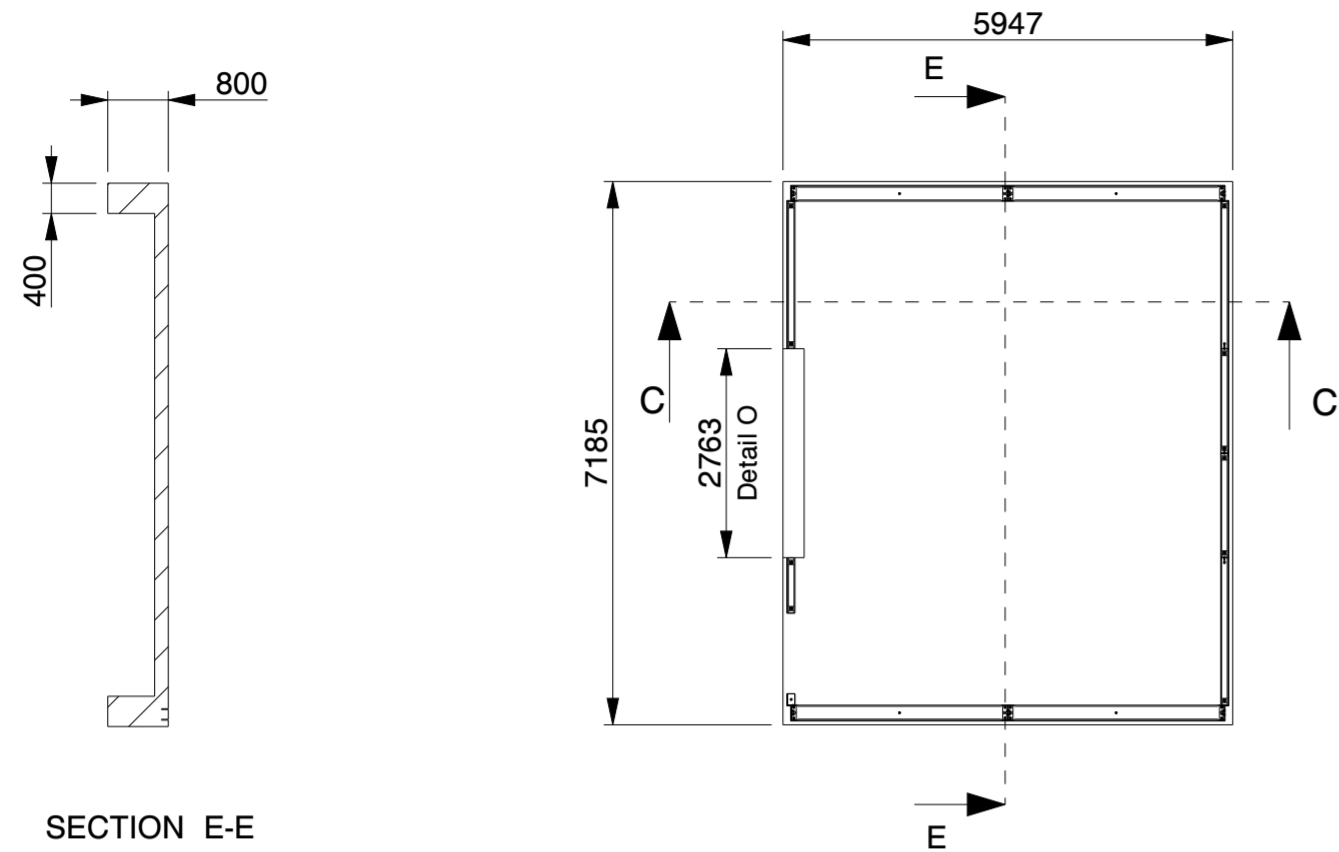

SECTION E-E

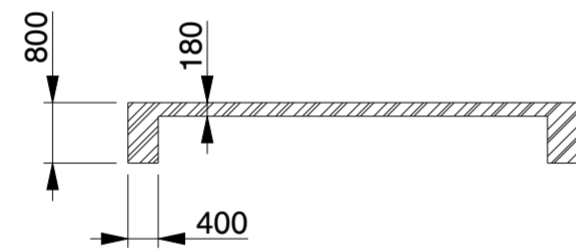

SECTION C-C

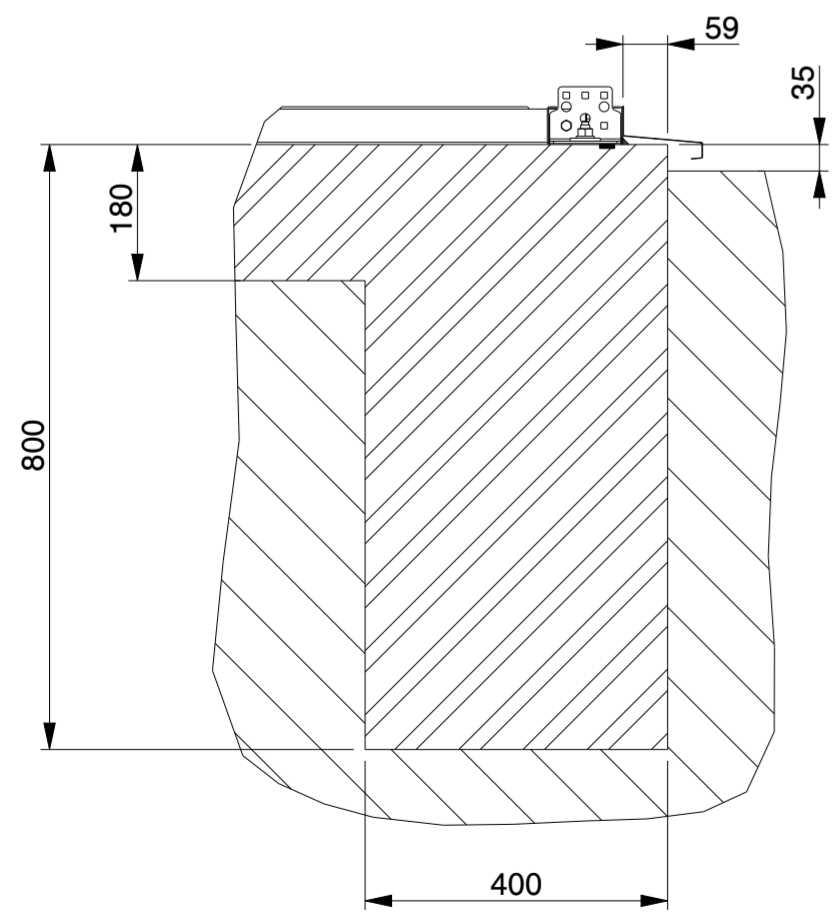

SECTION C-C
SCALE 1:10

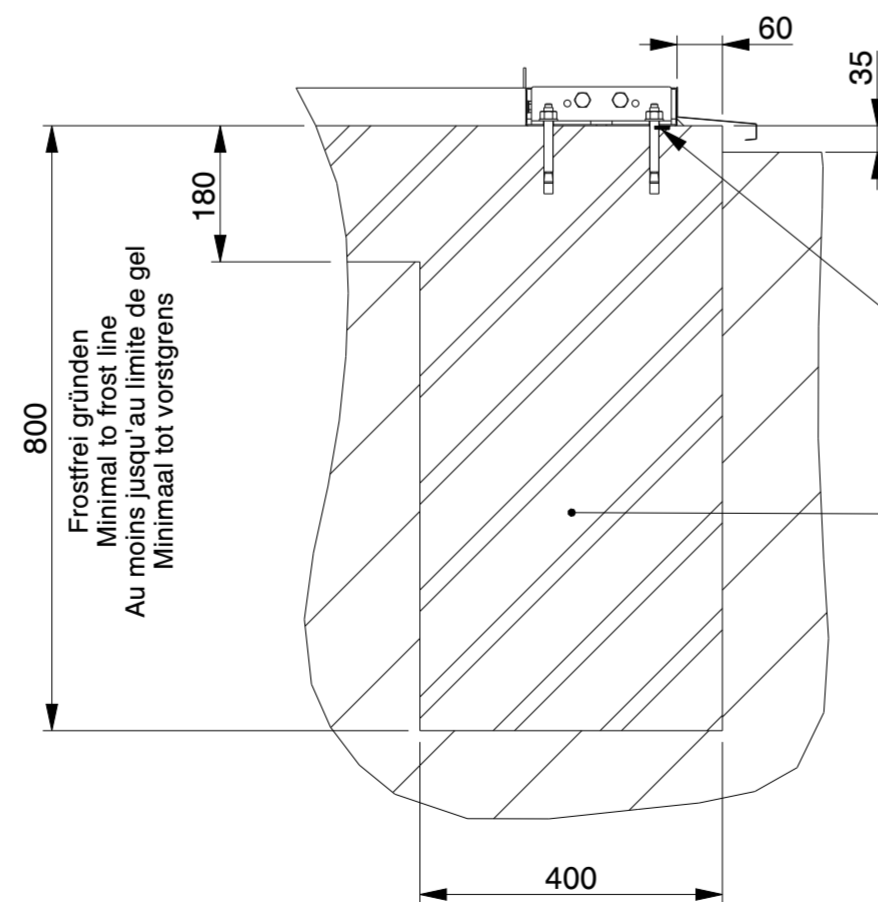

SECTION E-E
SCALE 1:10

Butyl tape / Tixopalte sealing option
Butylband / Tixopalte Abdichtung Option
Ruban en butyle / joint en Tixopalte Option
Butylband / Tixopalte afdichting optie

Bewehrungsstahl wie in der Statik angegeben
Reinforcement bar as indicated in the
structural calculation
Armature de béton comme indique dans
le calcul de construction
betonstaal volgens de statische berekening

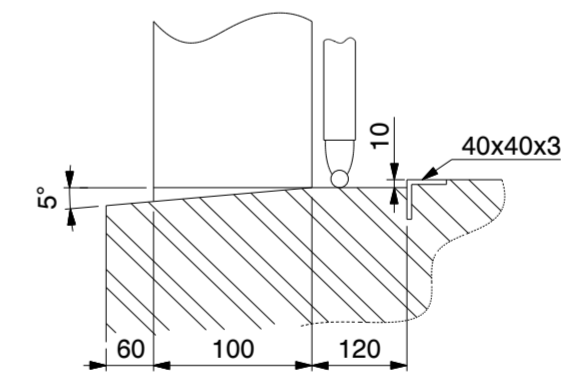

DETAIL O
(NOT TO SCALE)

Genehmigung / Approval / Goedkeuring

Kundenname: Client name: Klantnaam:	Firmenstempel: Company stamp: Firmastempel:
Datum: Date: Datum:	
Unterschrift: Signature: Handtekening:	

Betonplaat / Betonplatte / Concrete slab / Dalle de béton

KROFTMAN	LASERCUT ACCORDING: EN-ISO 9013-5-4-1		MATERIAL: See List	
	MATERIAL CERTIFICATE: 3.1 (OR 2.2 WHEN S235JR)		TREATMENT: -	
	GALVANIZING ACCORDING: EN ISO 1461		STATUS: Released	
	BEND RADIUS UNLESS DEFINED R _i =1			
TOLERANCES UNLESS OTHERWISE SPECIFIED:				
GENERAL ROUGHNESS R _a ✓	DIMENSION: ±	ANGLE: ±°	MODEL NUMBER LCA00145	REVISION: 0
DESCRIPTION: Storage Building H7-33				
SCALE: 1:100	UNITS: mm	PROJECTION: [Symbol]	MODIFIED ON: 08-09-2023 MODIFIED BY: AVA	APPROVED ON: 08-09-2023 APPROVED BY: BVB
MASS: 5086,7 kg		Sheet 3 of 4		Size: A2

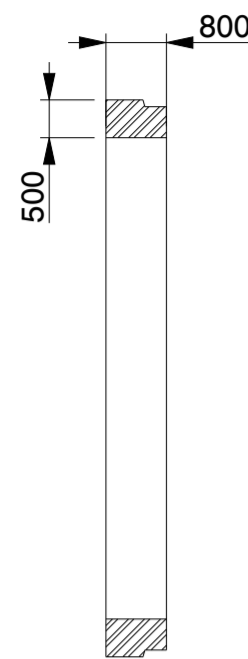

SECTION D-D

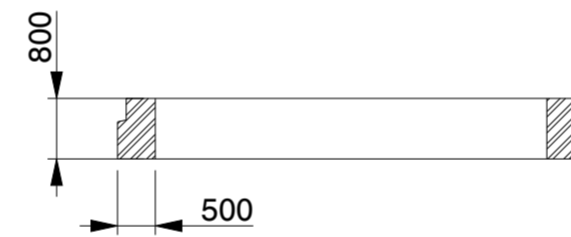
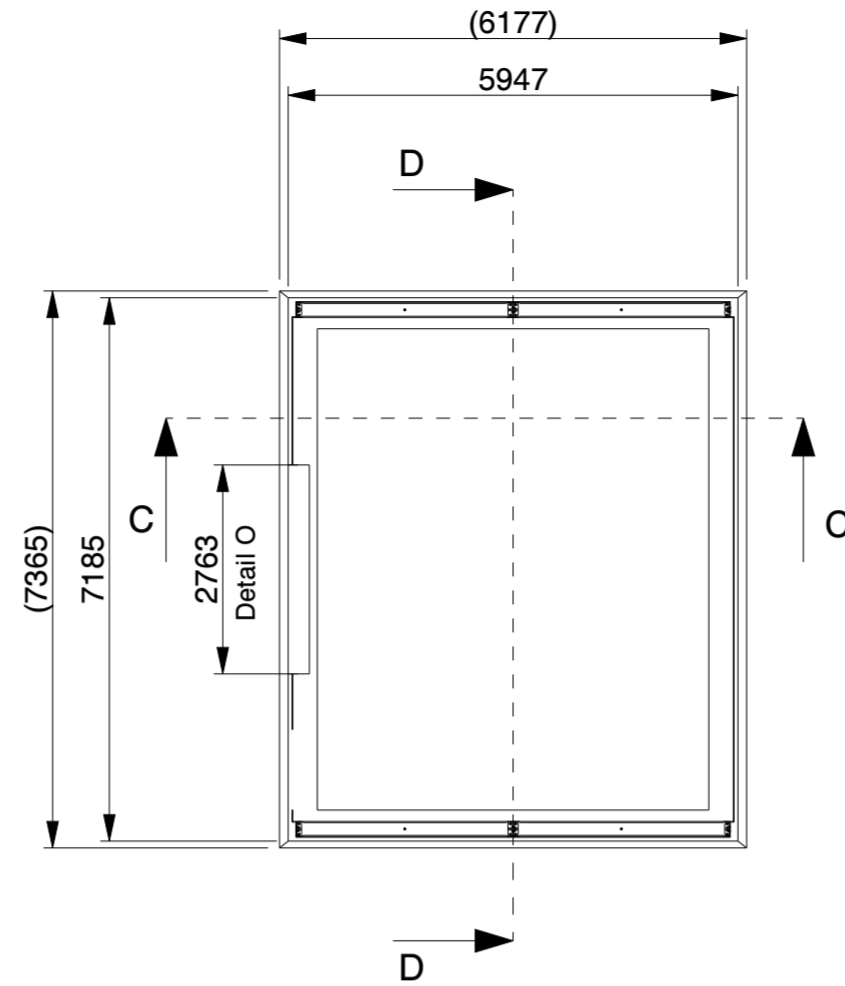

SECTION C-C

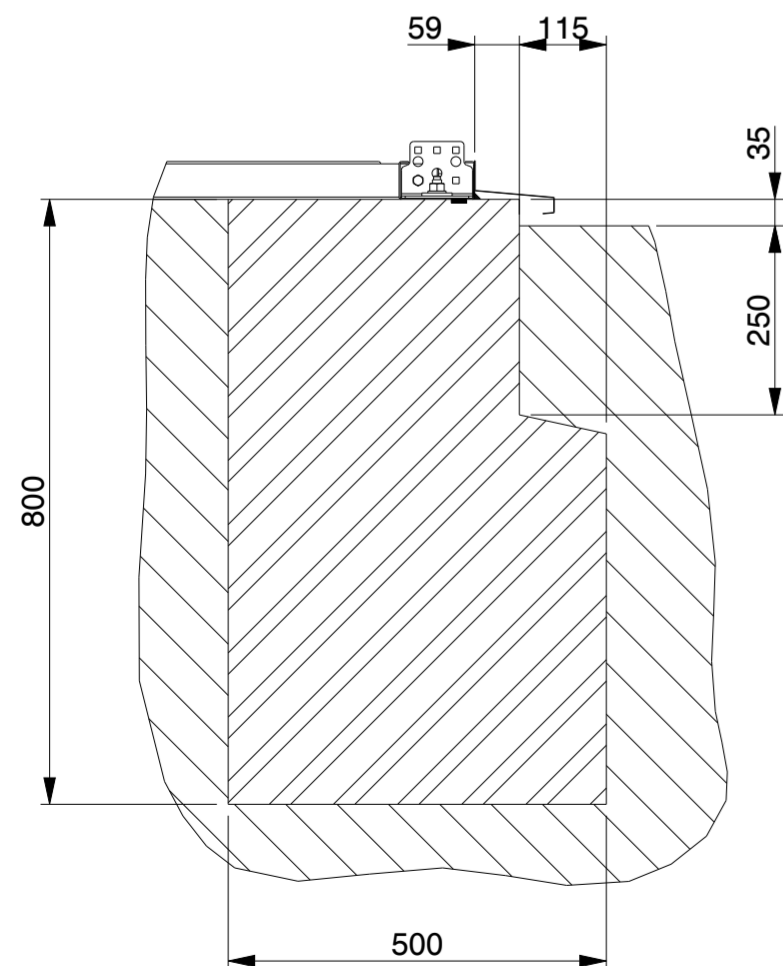

SECTION C-C
SCALE 1:10

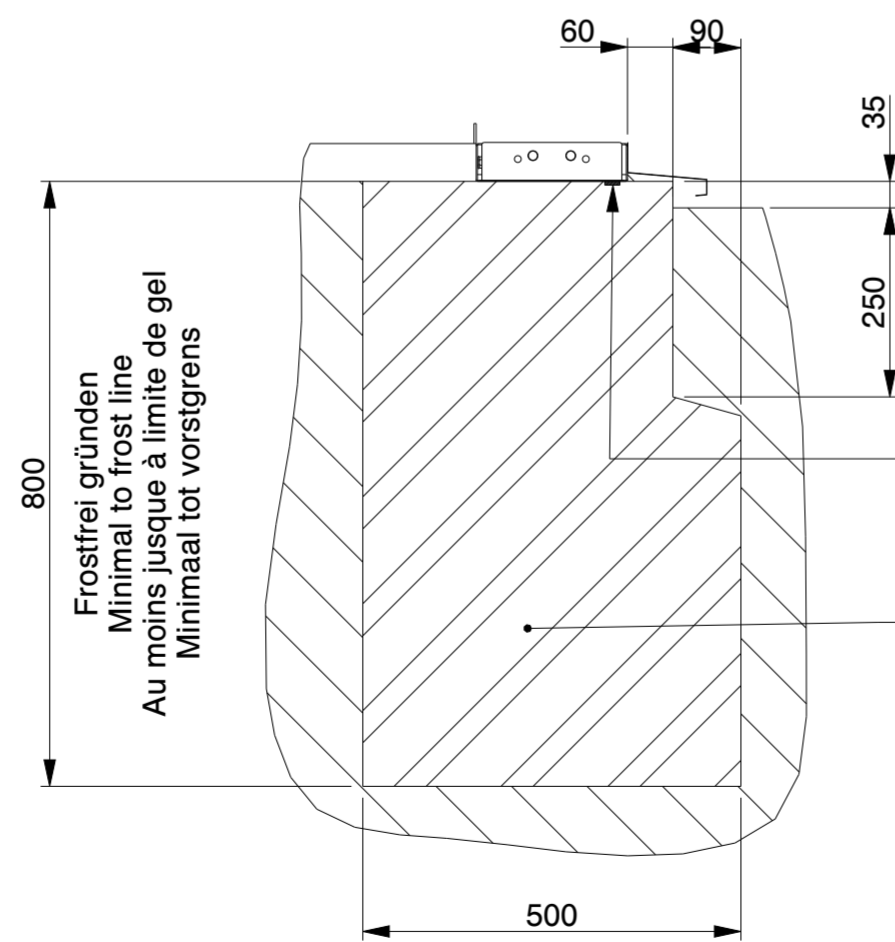

SECTION D-D
SCALE 1:10

Butyl tape / Tixophalte sealing option
Butylband / Tixophalte Abdichtung
Ruban en butyle / joint en Tixophalte option
Butylband / Tixophalte afdichting optie

Bewehrungsstahl wie in der Statik angegeben
Concrete reinforcement as indicated in
the structural calculation
Armature de béton comme indique dans le clacul
de construction
betonbewapening zoals in de
constructiebepening aangegeven

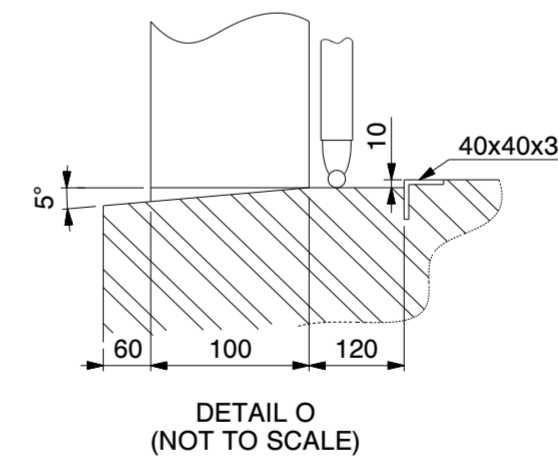

DETAIL O
(NOT TO SCALE)

Genehmigung / Approval / Goedkeuring		
Kundenname: Client name: Klantnaam:		Firmenstempel: Company stamp: Firmastempel:
Datum: Date: Datum:		
Unterschrift: Signature: Handtekening:		

Strookfundering / Streifenfundament /
Strip foundation / Fondation en bande

KROFTMAN	LASERCUT ACCORDING: EN-ISO 9013-5-4-1		MATERIAL: See List	
	MATERIAL CERTIFICATE: 3.1 (OR 2.2 WHEN S235JR)		TREATMENT: -	
	GALVANIZING ACCORDING: EN ISO 1461		STATUS: Released	
	BEND RADIUS UNLESS DEFINED R _i =1			
TOLERANCES UNLESS OTHERWISE SPECIFIED:				
GENERAL ROUGHNESS R _a ✓	DIMENSION: ±	ANGLE: ±°	MODEL NUMBER LCA00145	REVISION: 0
DESCRIPTION: Storage Building H7-33				
SCALE: 1:100	UNITS: mm	PROJECTION: [Symbol]	MODIFIED ON: 08-09-2023	APPROVED ON: 08-09-2023
			MODIFIED BY: AVA	APPROVED BY: BVB
			MASS: 5086,7 kg	Sheet 4 of 4 Size: A2

© KROFTMAN STRUCTURES B.V. Duplication and copying without written permission of the owner is prohibited