

Container shelter/ Containerüberdachung / Abris sur containers

KROFTMAN CT-A-1512

Assembly manual for main frame
Montageanleitung für den Hauptrahmen
Manuel d'assemblage du cadre principal

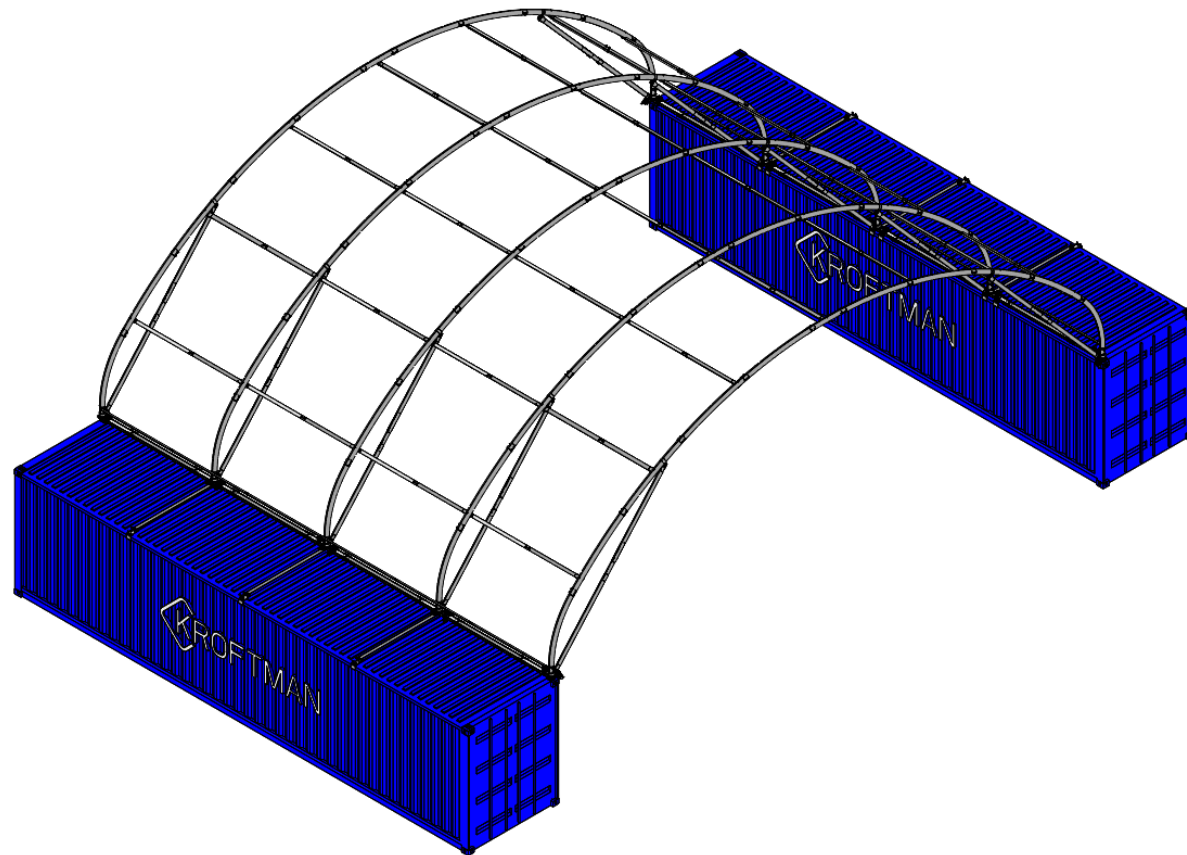

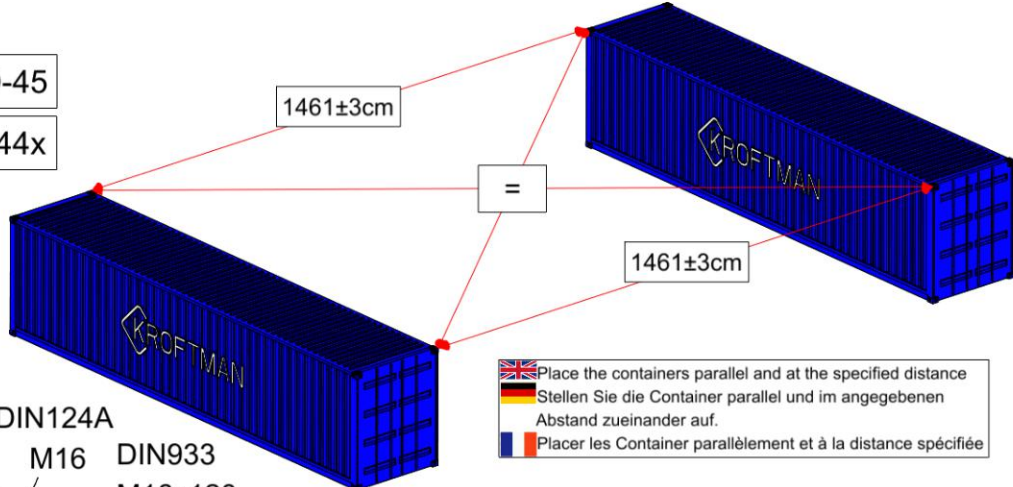
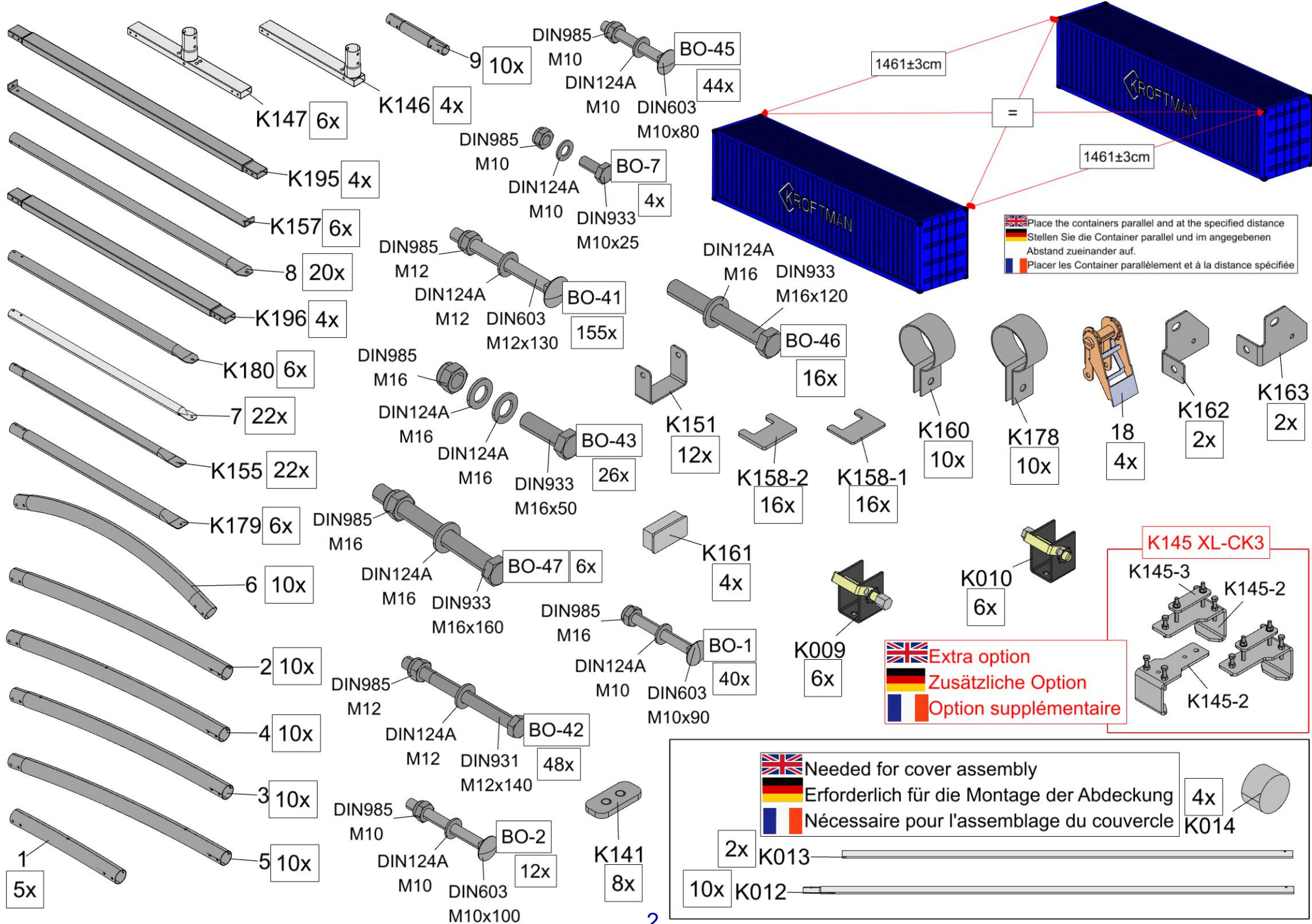

Place the containers parallel and at the specified distance
 Stellen Sie die Container parallel und im angegebenen Abstand zueinander auf.
 Placer les Container parallèlement et à la distance spécifiée

Extra option
 Zusätzliche Option
 Option supplémentaire

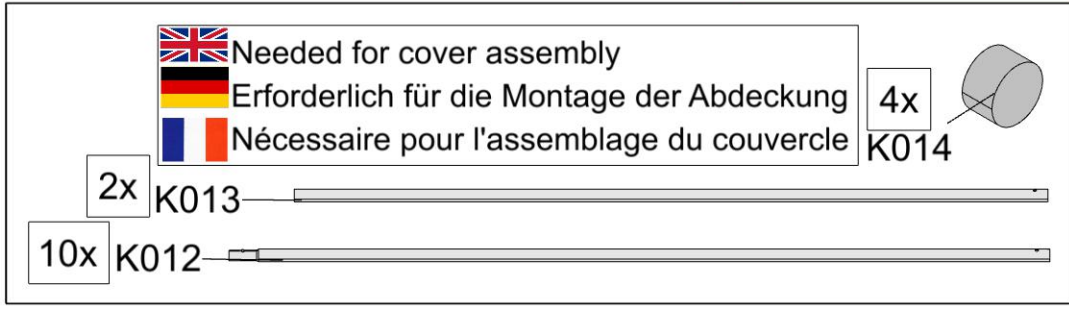

 Left side
 Linke Seite
 Côté gauche

 The right side base rail is mirrored
 Die rechte Grundschiene ist gespiegelt
 Le rail de la base droite est en miroir

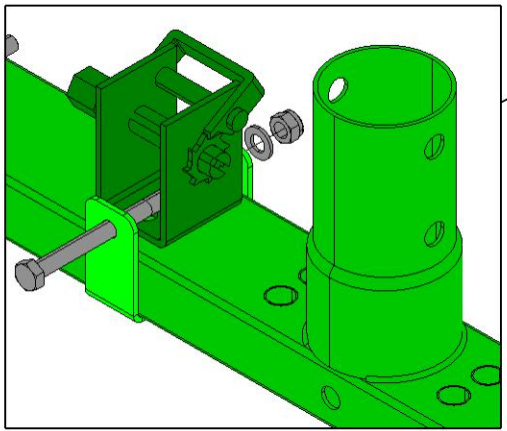
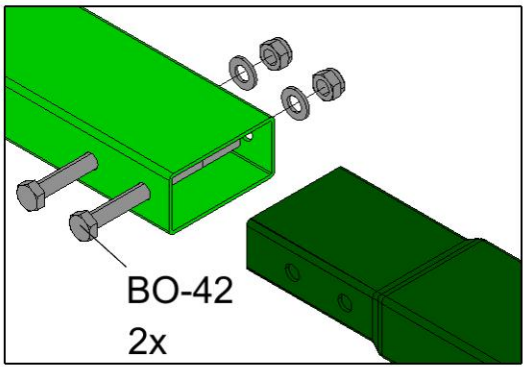
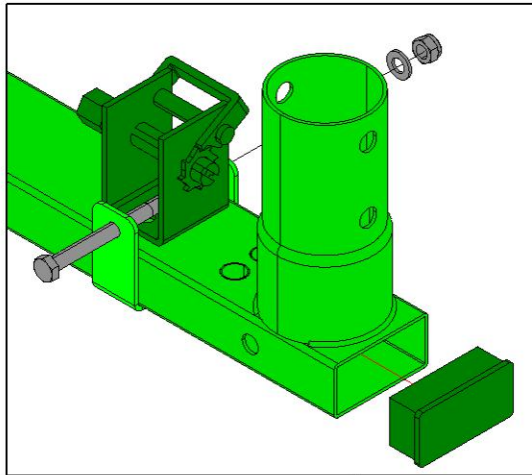
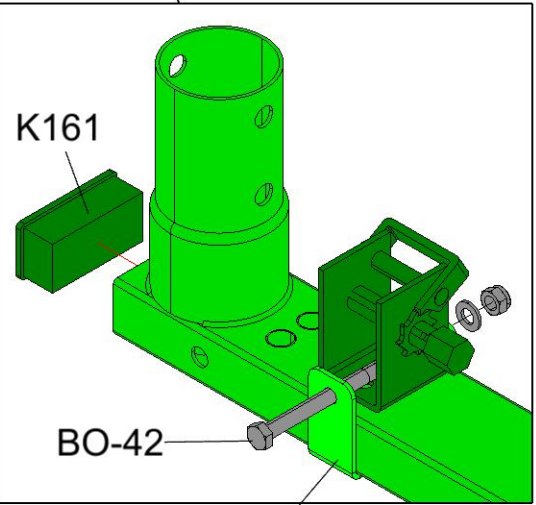
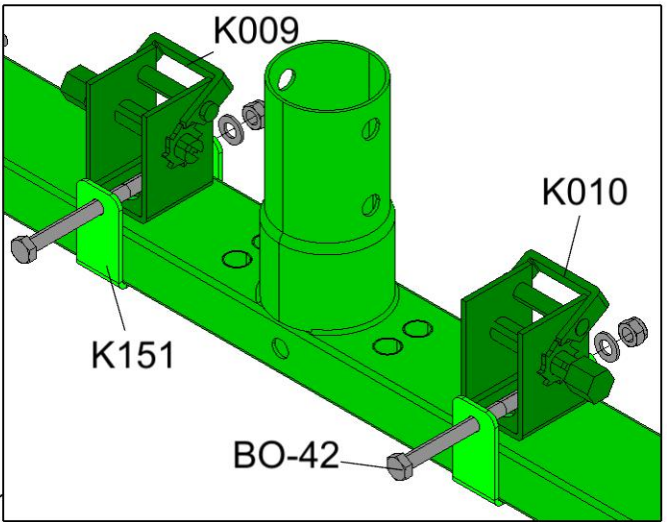
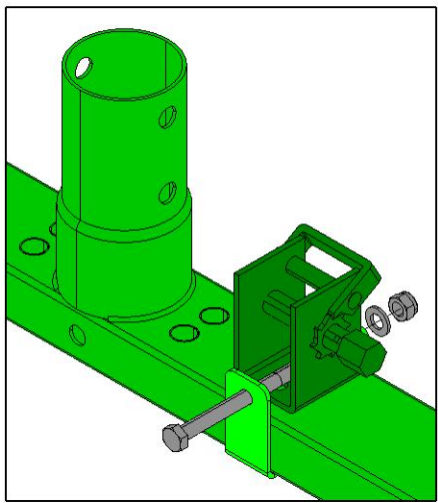
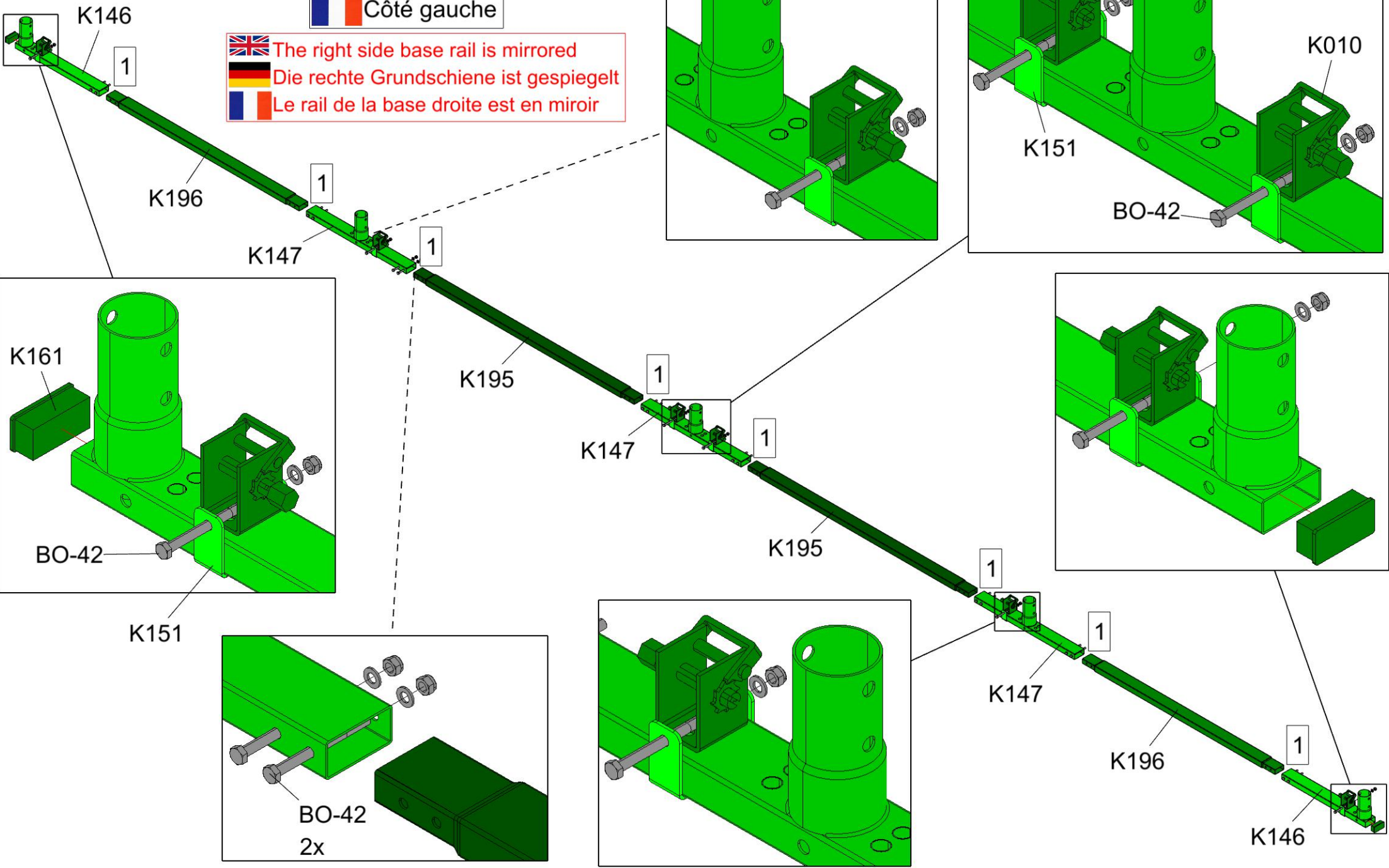



Place and symmetrically align the base rail on top of the container. Mark the position of the K145-2 clamps as close to the tubes as possible, remove the base rail and place the clamps. Level the clamps and tighten the nuts hand-tight.



Setzen Sie die Grundschiene auf den Container und richten Sie sie symmetrisch aus. Die Position der K145-2-Klemmen so nah wie möglich an den Rohren markieren, die Grundschiene entfernen und die Klemmen anbringen. Richten Sie die Klemmen aus und ziehen Sie die Muttern handfest an.



Placer et aligner symétriquement le rail de base sur le dessus du conteneur. Marquer la position des pinces K145-2 le plus près possible des tubes, retirer le rail de base et placer les pinces. Mettez les pinces à niveau et serrez les écrous à la main.

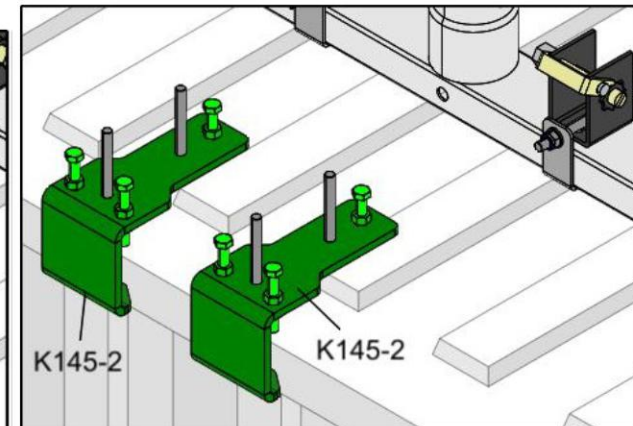
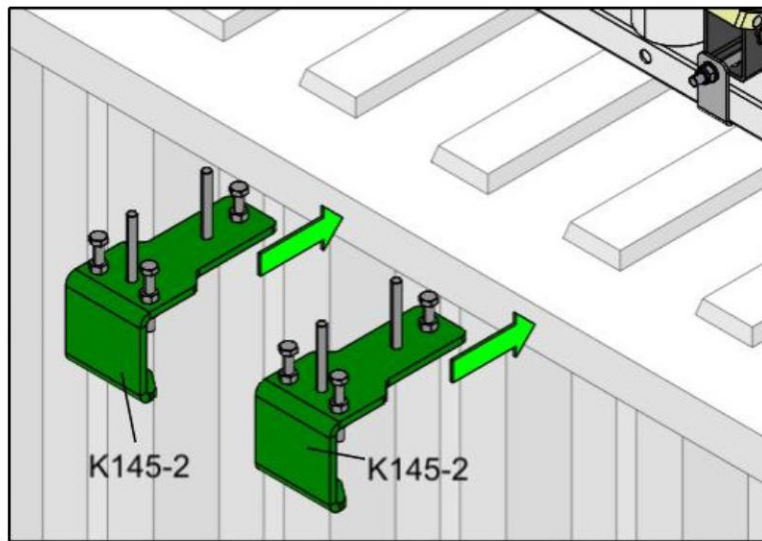
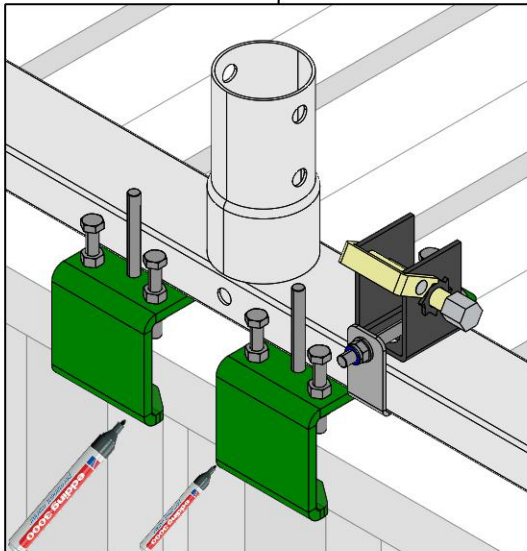
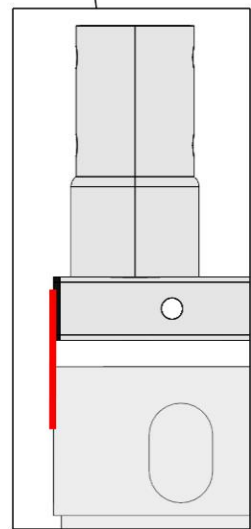
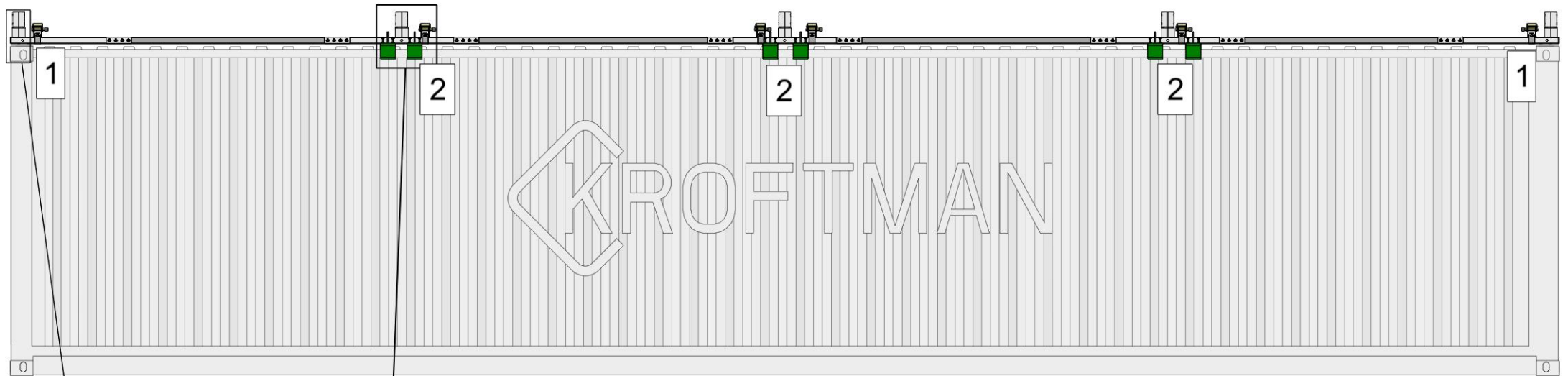

Same on both containers





Bei beiden Containern dasselbe





Idem pour les deux conteneurs

 Install the plate and secure everything by tightening the nuts hand-tight.

 Montieren Sie die Platte an und sichern Sie alles, indem Sie die Muttern handfest anziehen.

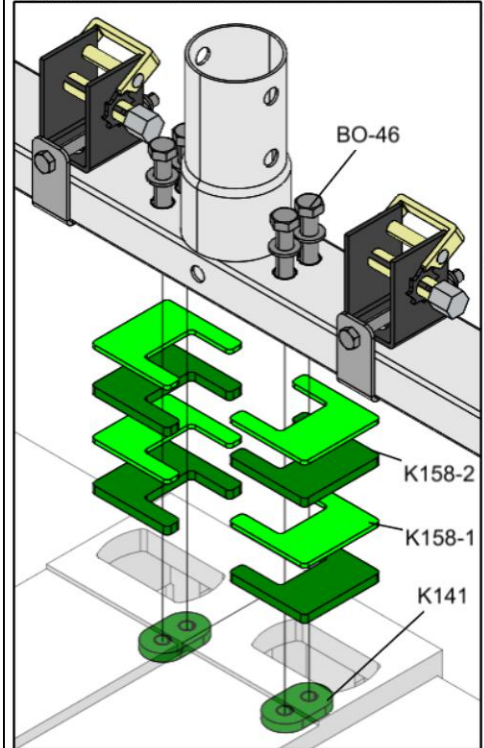
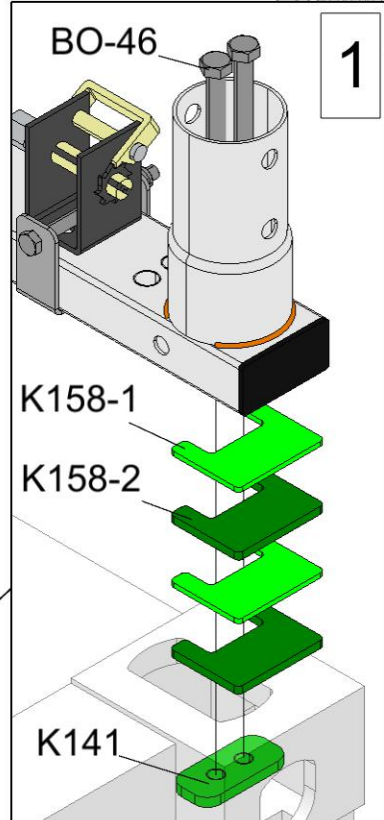
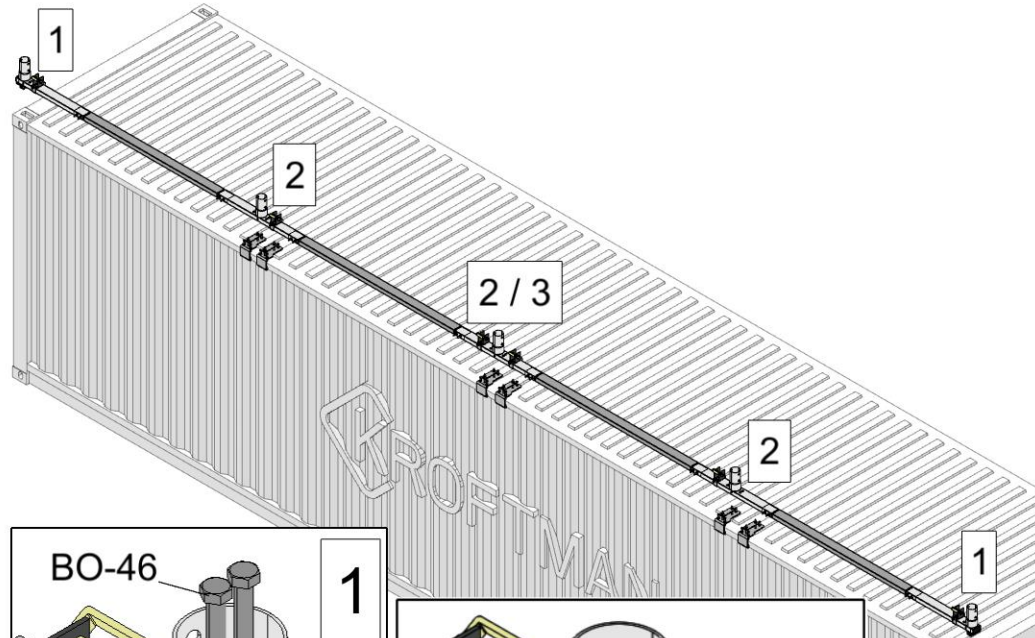
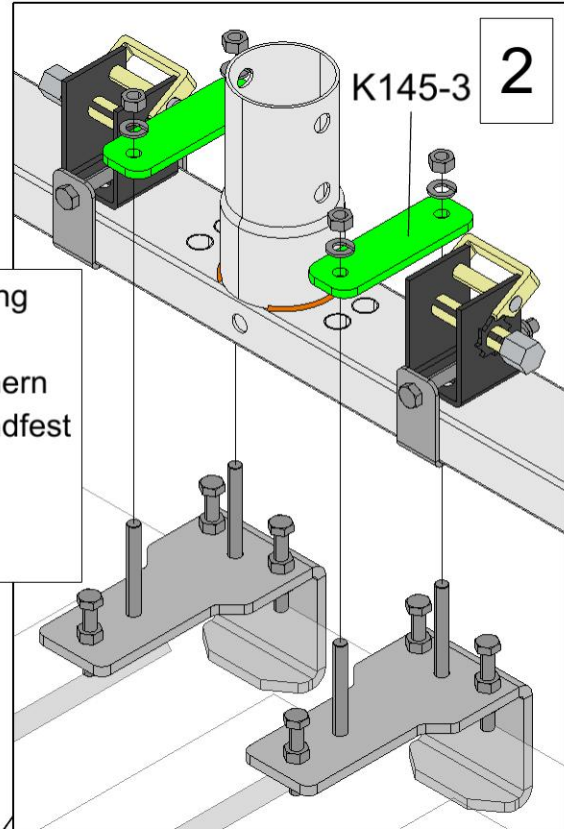
 Installez la plaque et fixez le tout en serrant les écrous à la main.





 On the corners of the container use a combination of plates that fits best.

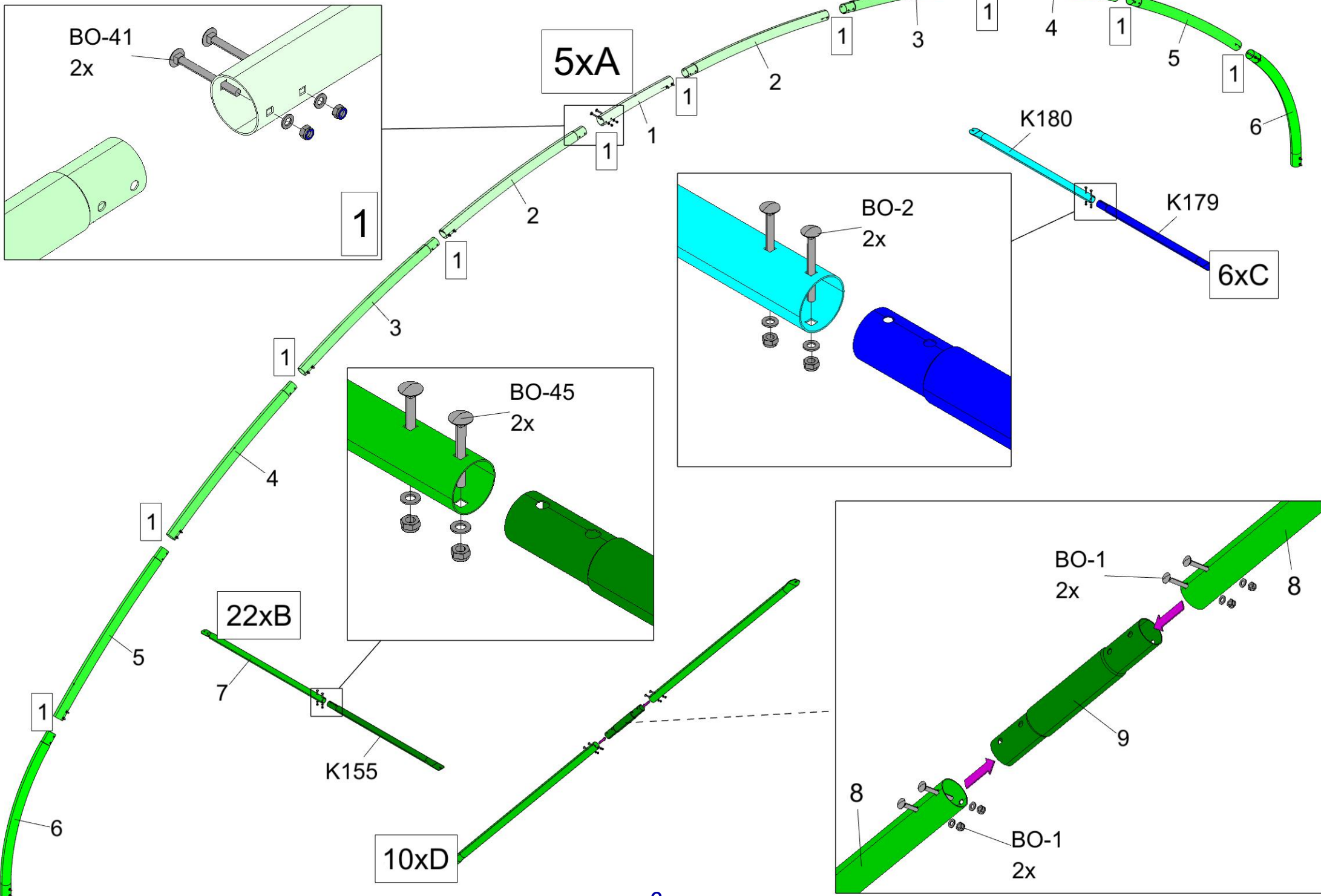

 Verwenden Sie an den Ecken des Containers eine Kombination von Platten, die am besten passt.

 Sur les coins du conteneur, utilisez une combinaison de plaques qui convient le mieux.

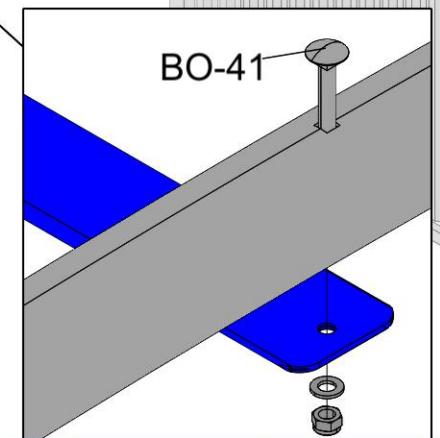
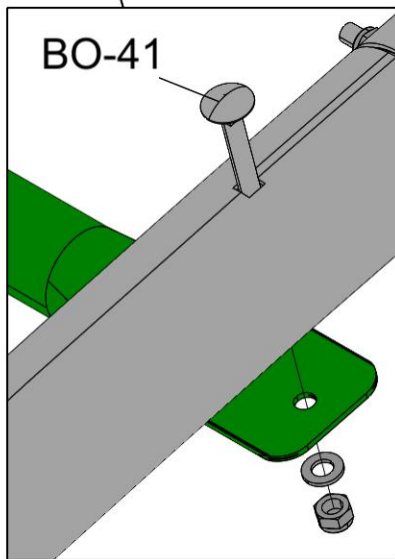
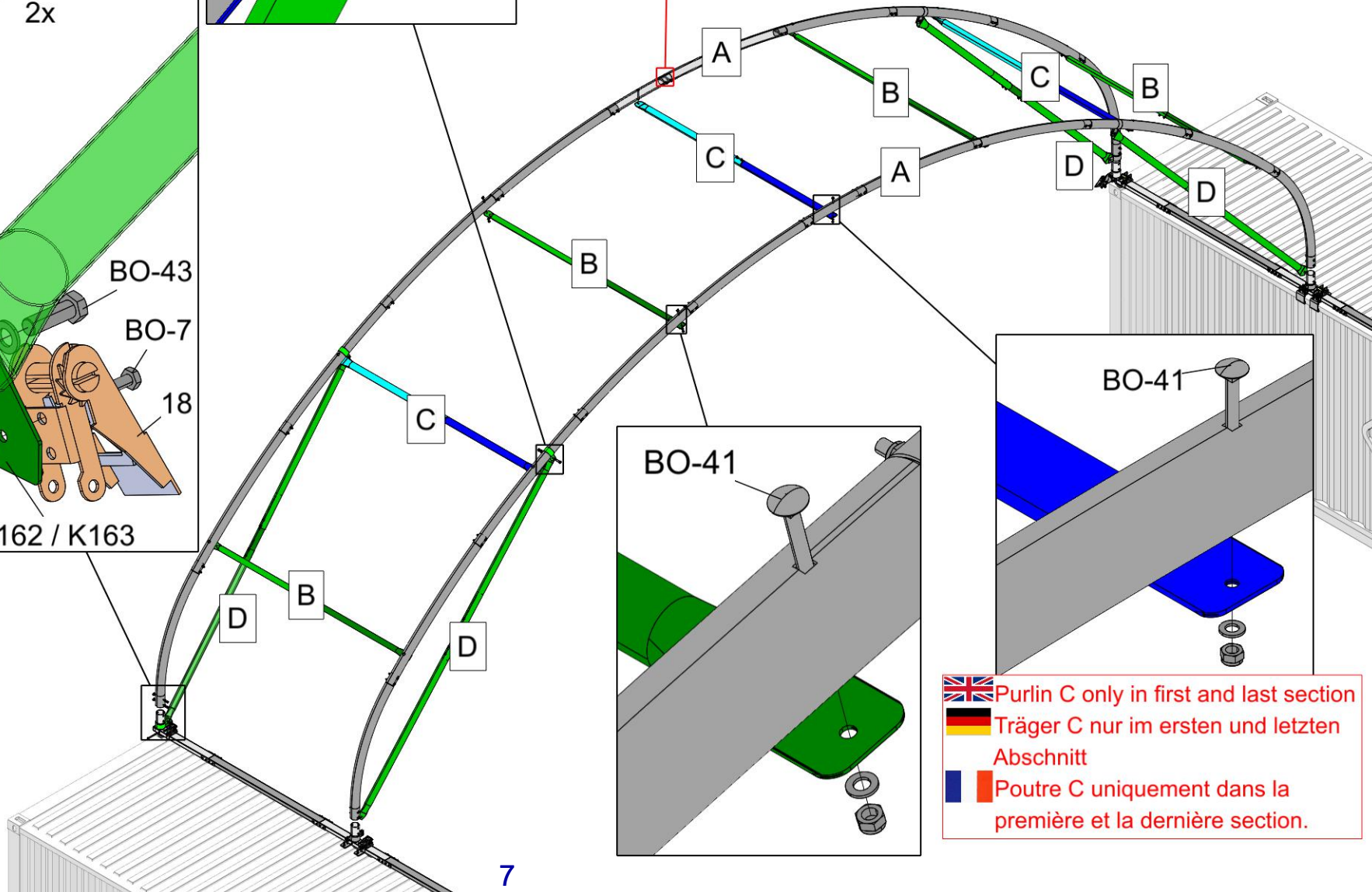
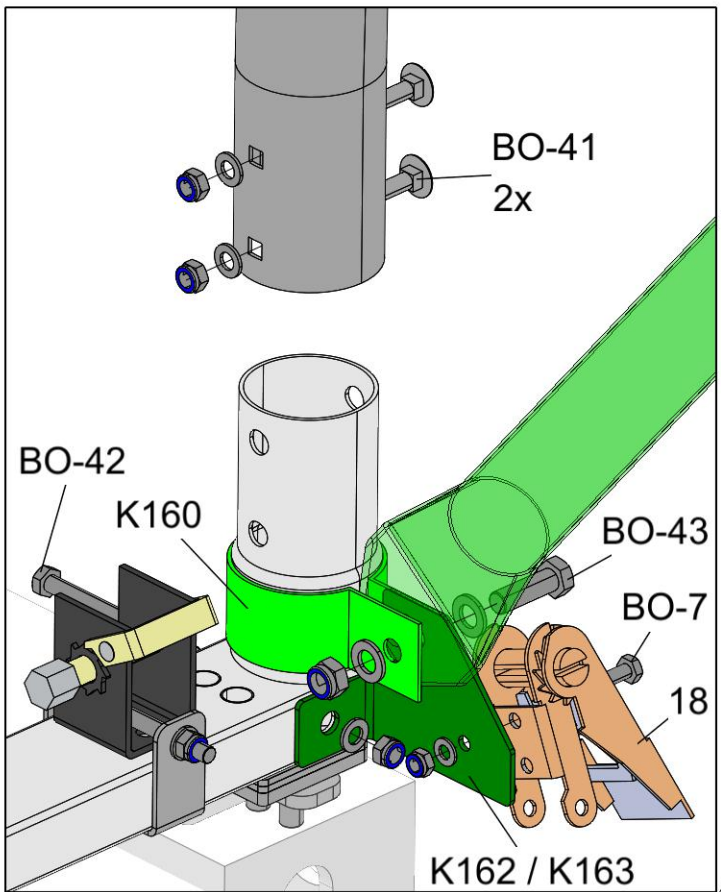
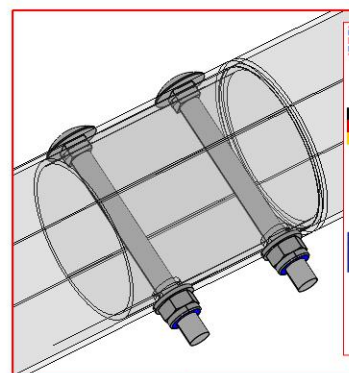
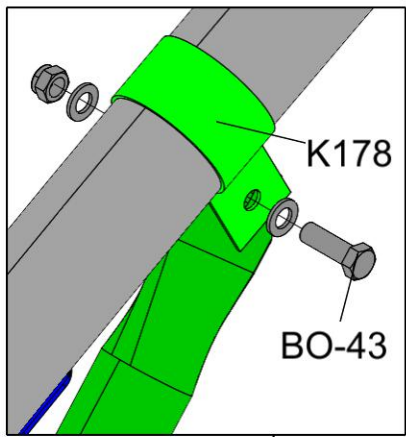

 When placing the first and last arch make sure the boltheads point outwards
 Achten Sie beim Anbringen des ersten und letzten Bogens darauf, dass der Schraubenkopf nach außen zeigt.
 Lorsque vous placez le premier et le dernier arc, veuillez à ce que la tête de boulon soit orientée vers l'extérieur.



 Purlin C only in first and last section
 Träger C nur im ersten und letzten Abschnitt
 Poutre C uniquement dans la première et la dernière section.

