

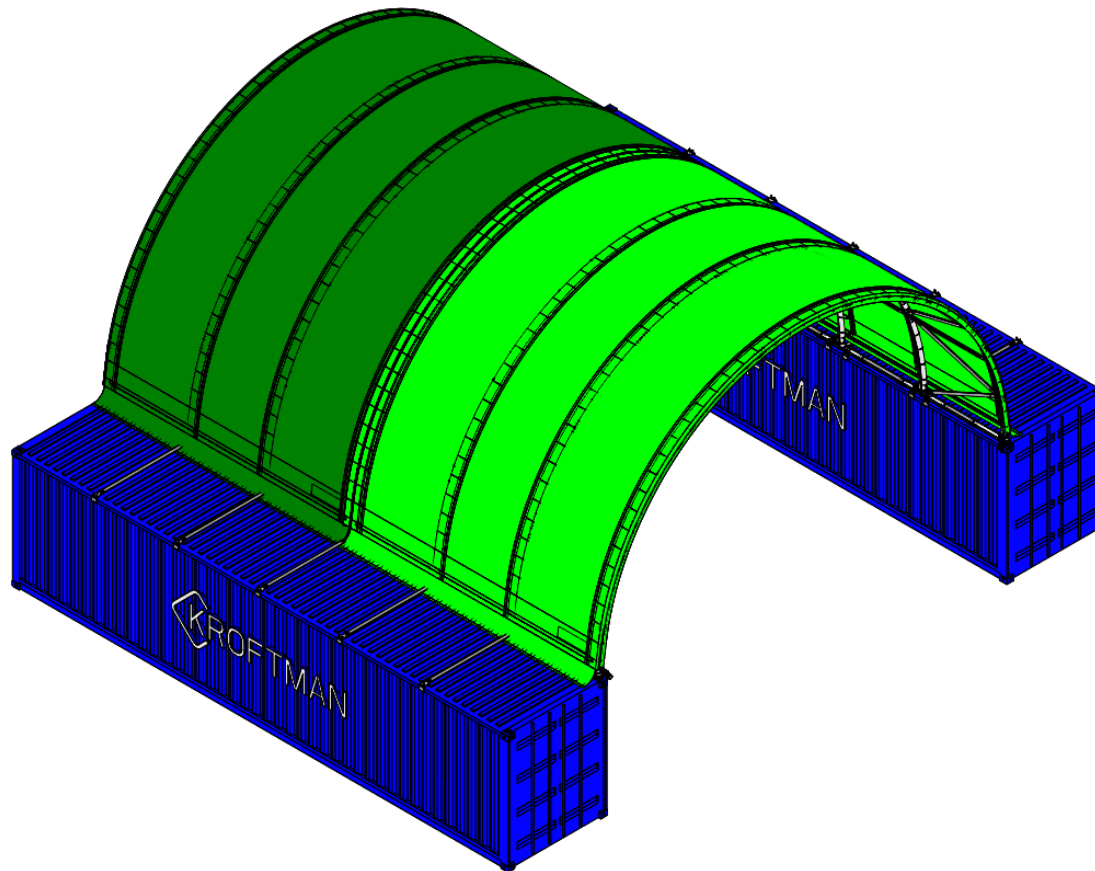



# KROFTMAN CT-A-1006-HD / 1012-HD

Assembly manual for main cover



Montageanleitung für die Hauptabdeckung

Manuel d'assemblage du couvercle principal



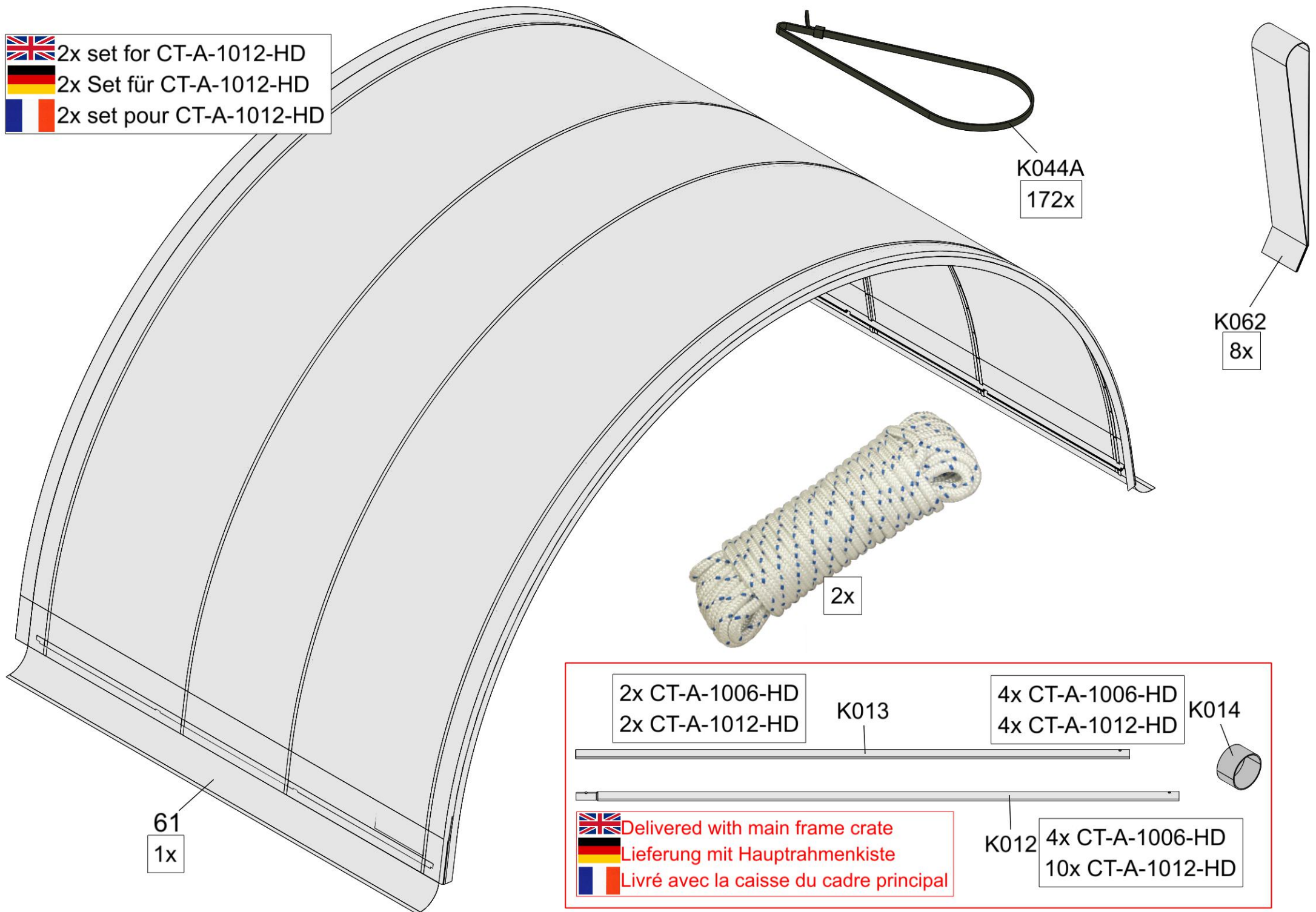

 2x set for CT-A-1012-HD  
 2x Set für CT-A-1012-HD  
 2x set pour CT-A-1012-HD



 Delivered with main frame crate  
 Lieferung mit Hauptrahmenkiste  
 Livré avec la caisse du cadre principal

### CT-S-1012-HD

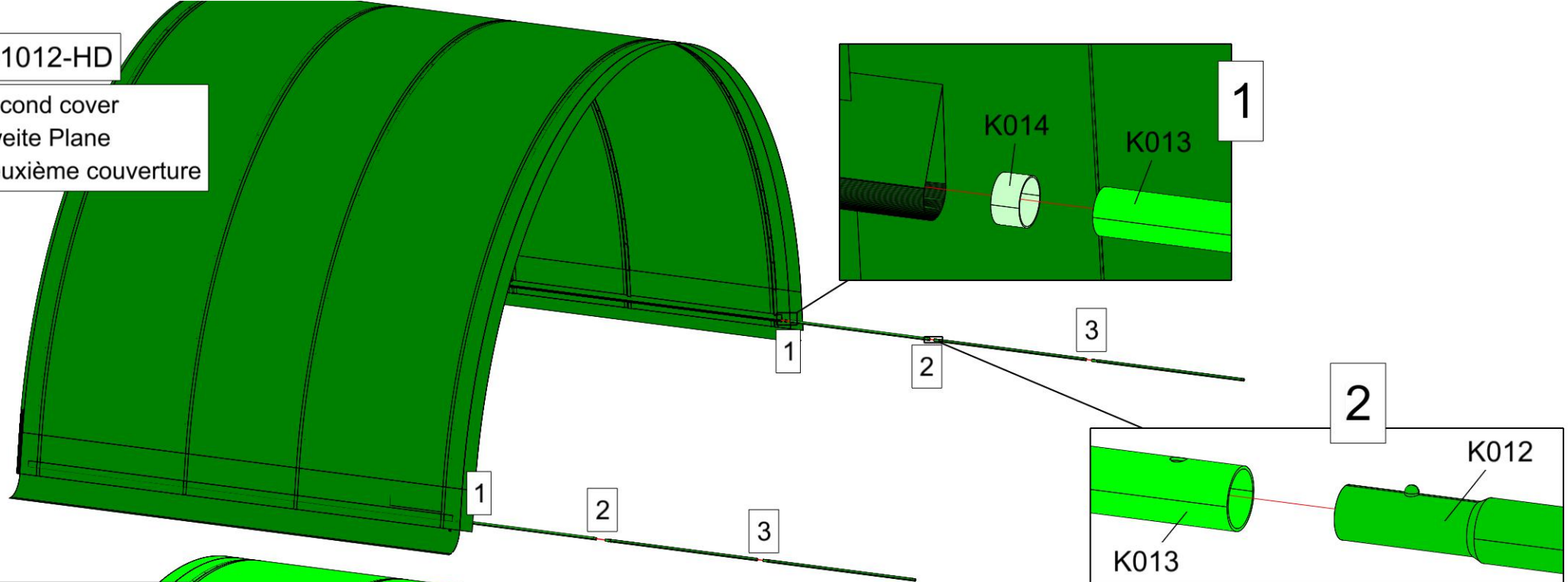

-  Second cover
-  Zweite Plane
-  Deuxième couverture



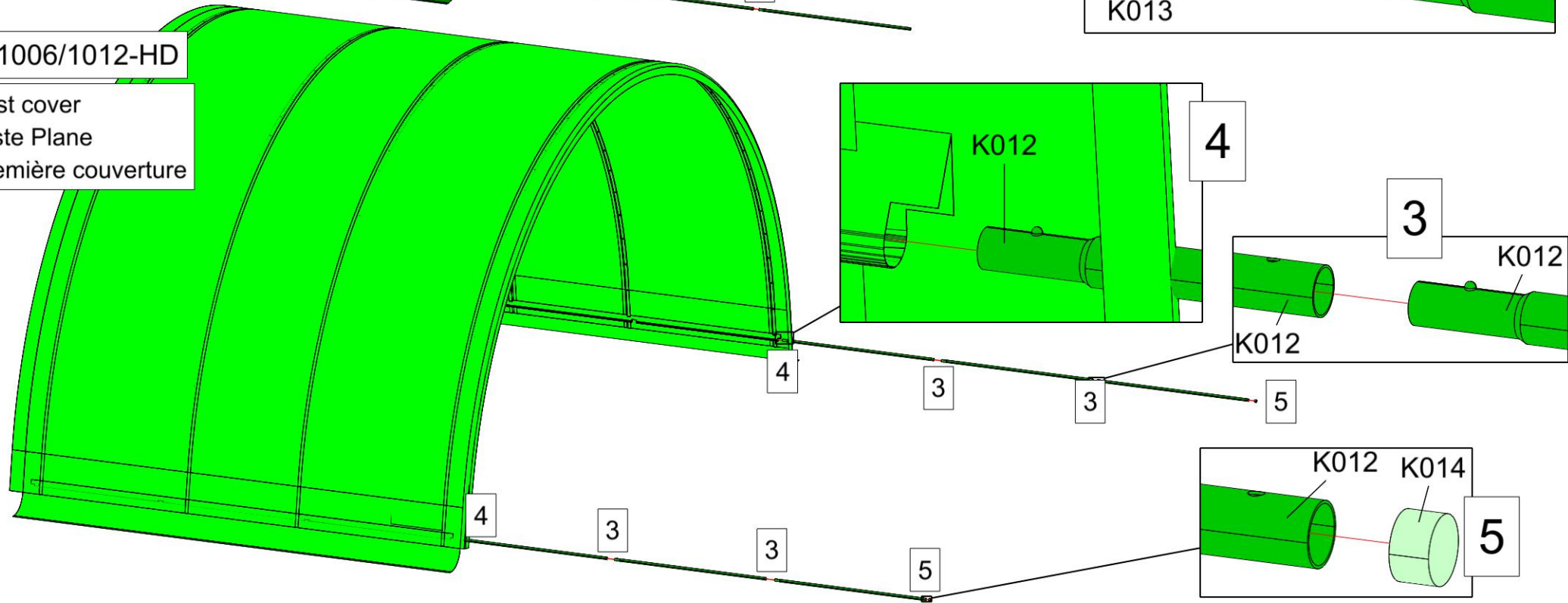

### CT-S-1006/1012-HD

-  First cover
-  Erste Plane
-  Première couverture





 Keep the wind direction in mind, so that water is not blown between the covers  
 Beachten Sie die Windrichtung, damit kein Wasser zwischen die Planen geblasen wird.  
 Gardez à l'esprit la direction du vent, afin que l'eau ne soit pas projetée entre les couvertures.

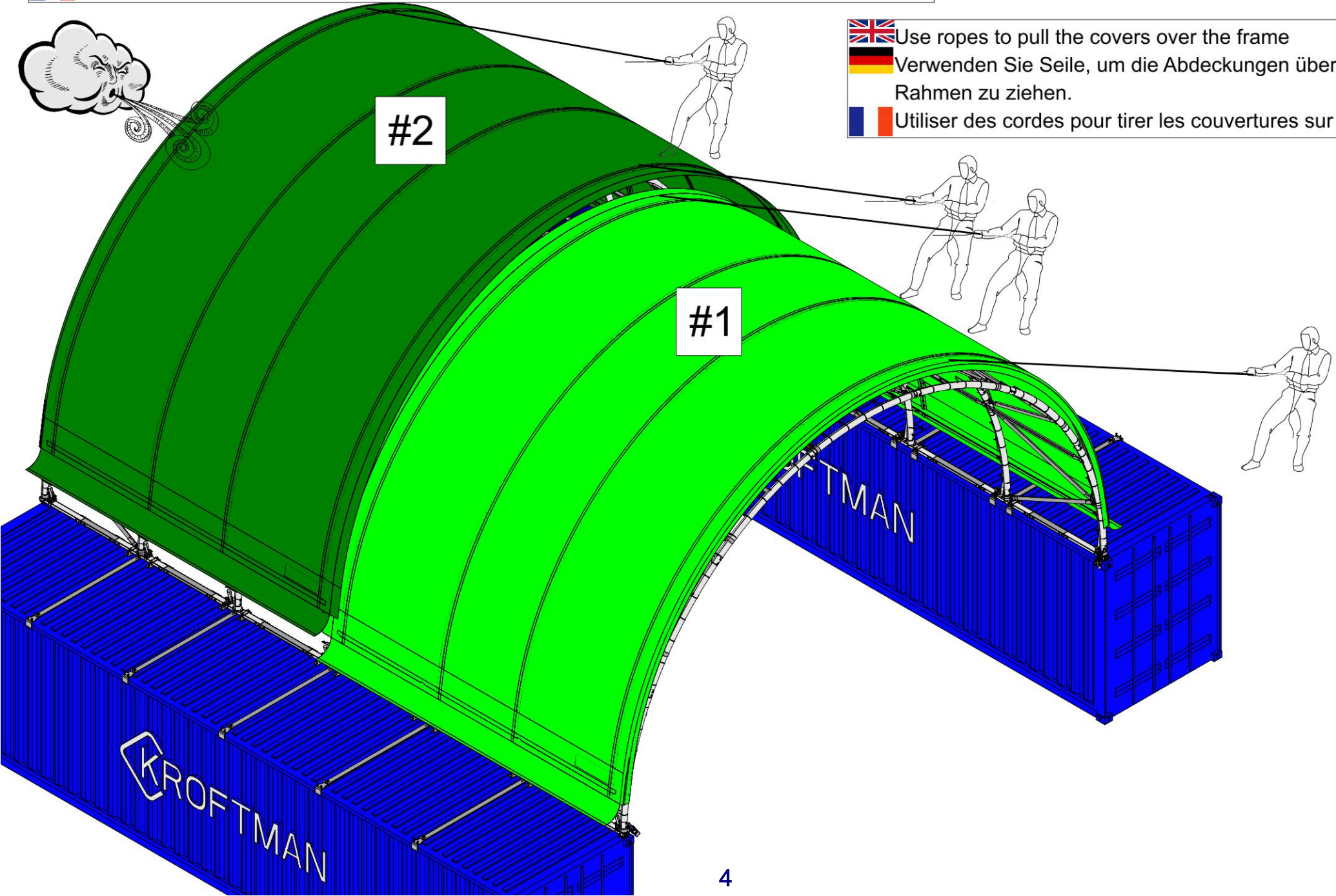

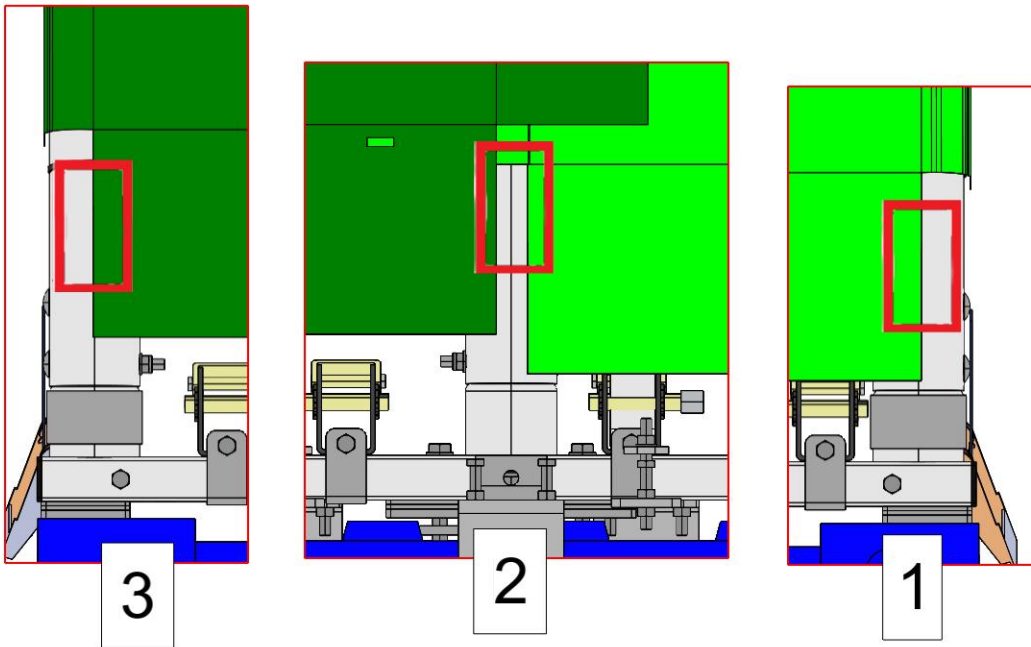
 Use ropes to pull the covers over the frame  
 Verwenden Sie Seile, um die Abdeckungen über den Rahmen zu ziehen.  
 Utiliser des cordes pour tirer les couvertures sur le cadre.





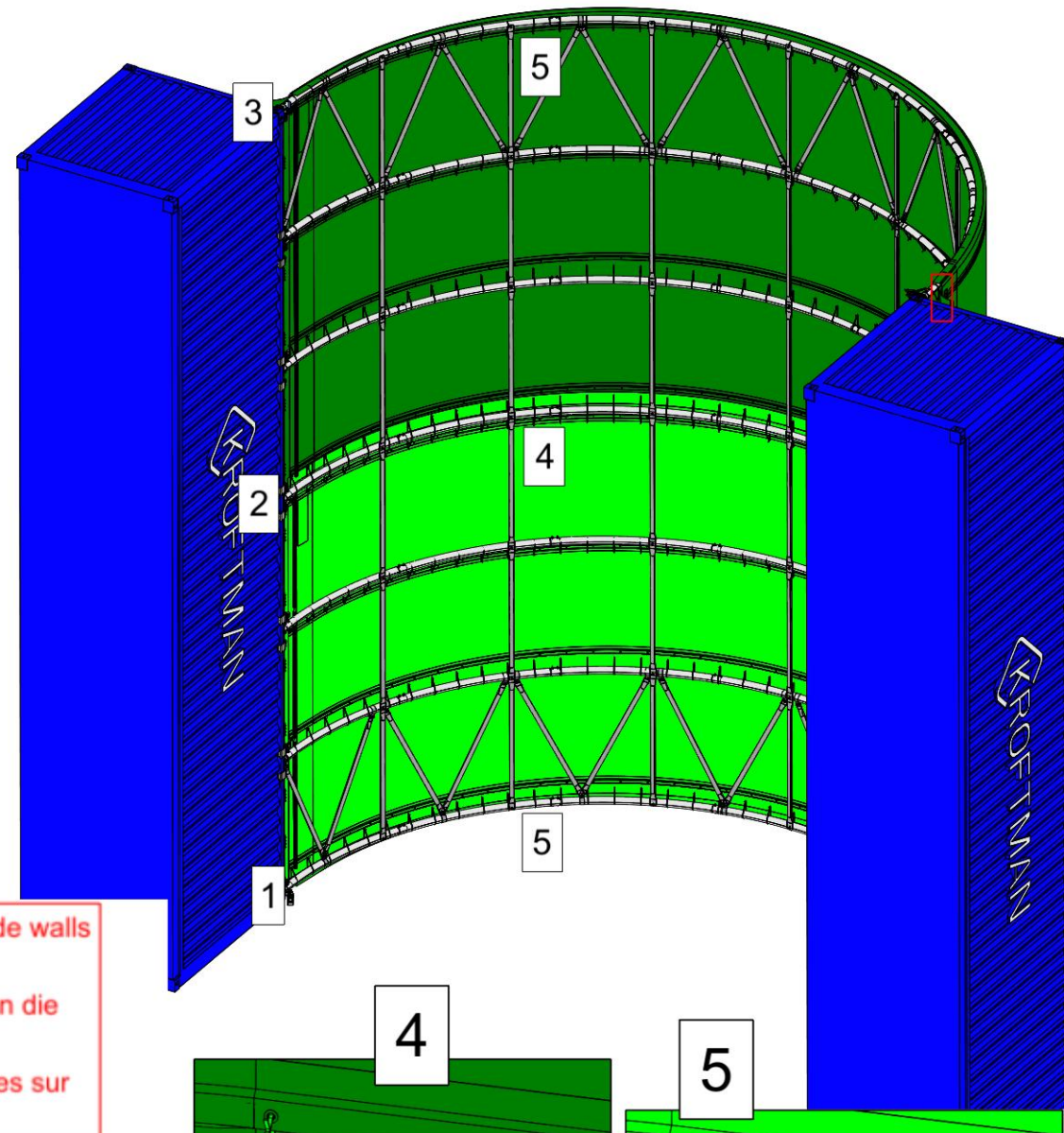

-  Make sure that the roof cover(s) are centered on the frame(s).
-  Achten Sie darauf, dass die Plane(n) in der Mitte des Dachrahmens zentriert sind.
-  Veillez à ce que le(s) couverture(s) de toit soit(nt) centré(s) sur la charpente.







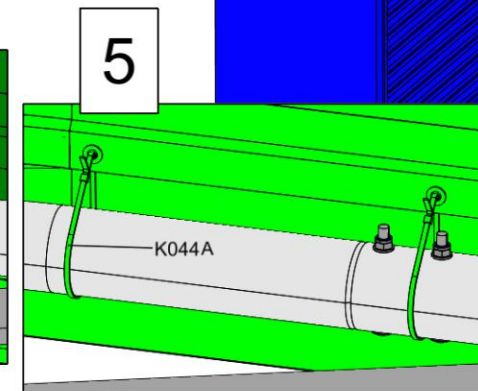
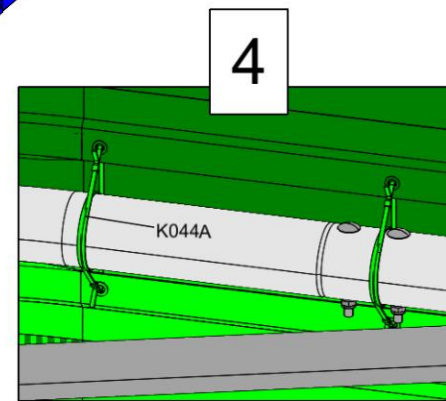

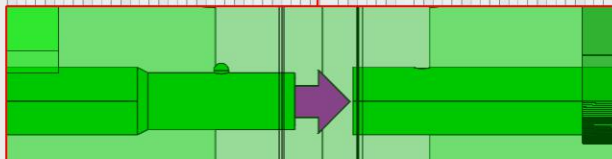
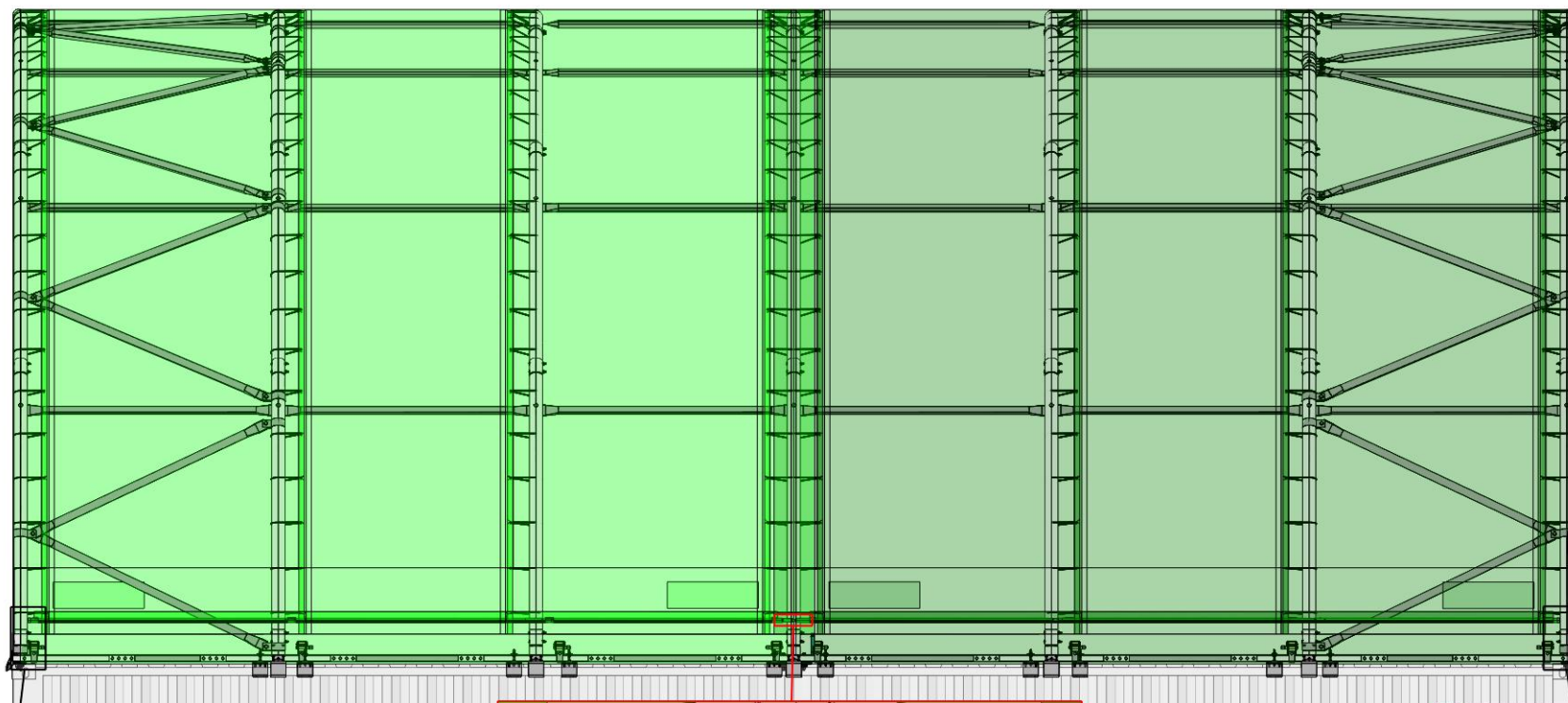
-  Make sure that the gutter keders on the side walls are aligned.
-  Stellen Sie sicher, dass die Rinnenkeder an die Seitenwänden ausgerichtet sind.
-  Assurez-vous que les keders des gouttières sur les parois latérales sont alignés.



-  Remove yellow section, when using the kedder gutter.
-  Markierten gelbe Abschnitt entfernen, wenn die Kederrinne verwendet wird.
-  Retirez la section jaune lors de l'utilisation de la gouttière à jonc.







 CT-S-1012-HD only, connect the tubes from both covers  
 Nur CT-S-1012-HD, verbinden Sie die Schläuche von beiden Planen  
 CT-S-1012-HD uniquement, connecter les tubes des deux couvercles

 Cut the last tube so that it ends before the last arch.  
 Schneiden Sie das letzte Rohr so ab, dass es vor dem letzten Bogen endet.  
 Couper le dernier tube de manière à ce qu'il se termine avant le dernier arc.

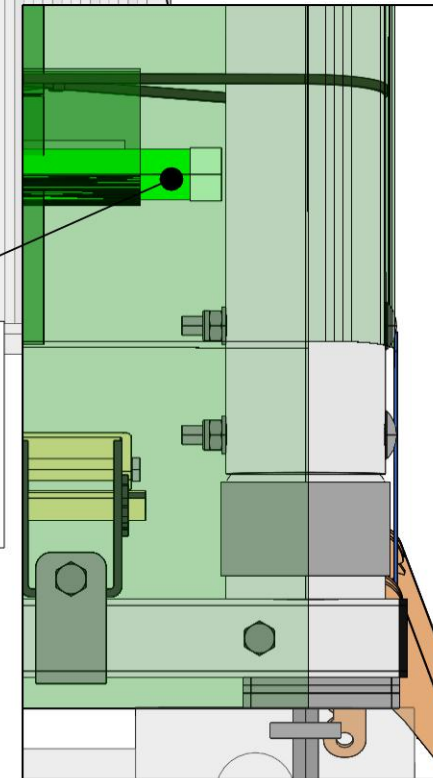
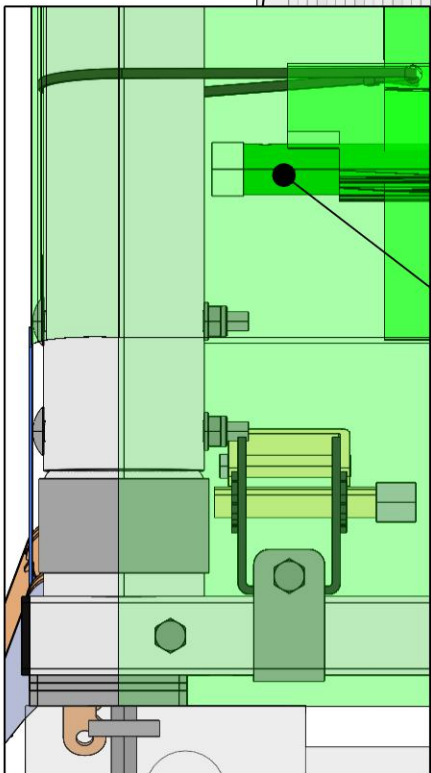
 Place the first tensioning tube (and cap) after the first arch.  
 Platzieren Sie den ersten Spannröhren (und die Kappe) nach dem ersten Bogen.  
 Placer le premier tube de tension (et le capuchon) après le premier arc.





 Use the "K062" straps and the "K009", "K010" ratchets to stretch the roof cover

 Verwenden Sie die Gurte "K062" und die Ratschen "K009" und "K010", um die Dachabdeckung zu spannen.

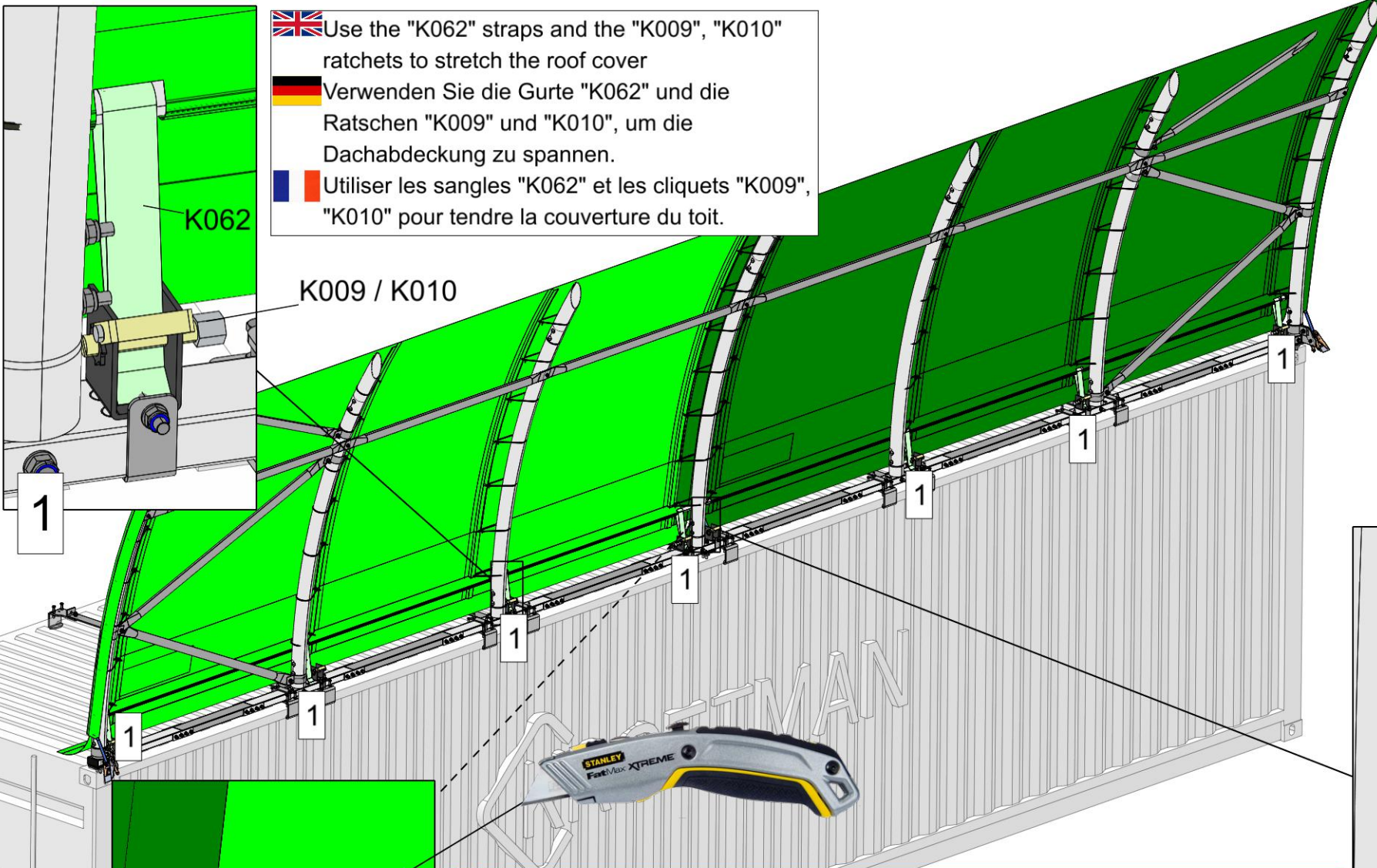
 Utiliser les sangles "K062" et les cliquets "K009", "K010" pour tendre la couverture du toit.





 **CT-S-1012-HD only**, cut a hole in the first cover, insert the strap of the second cover through it, attach the strap to the ratchet and tighten the strap

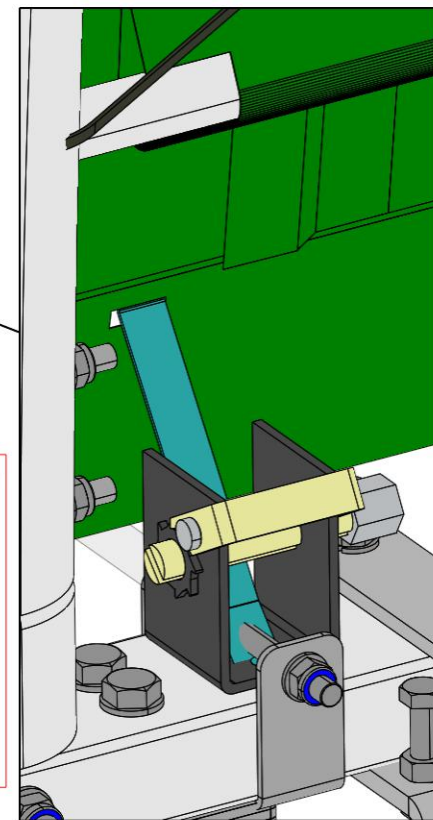

 **Nur CT-S-1012-HD**, schneiden Sie ein Loch in die erste Plane, führen Sie den Gurt der zweiten Plane hindurch, befestigen Sie den Gurt an der Ratsche und ziehen Sie den Gurt fest.

 **CT-S-1012-HD uniquement**, découpez un trou dans la première couverture, insérez la sangle de la deuxième couverture à travers cetrou, attachez la sangle au cliquet et serrez la sangle.

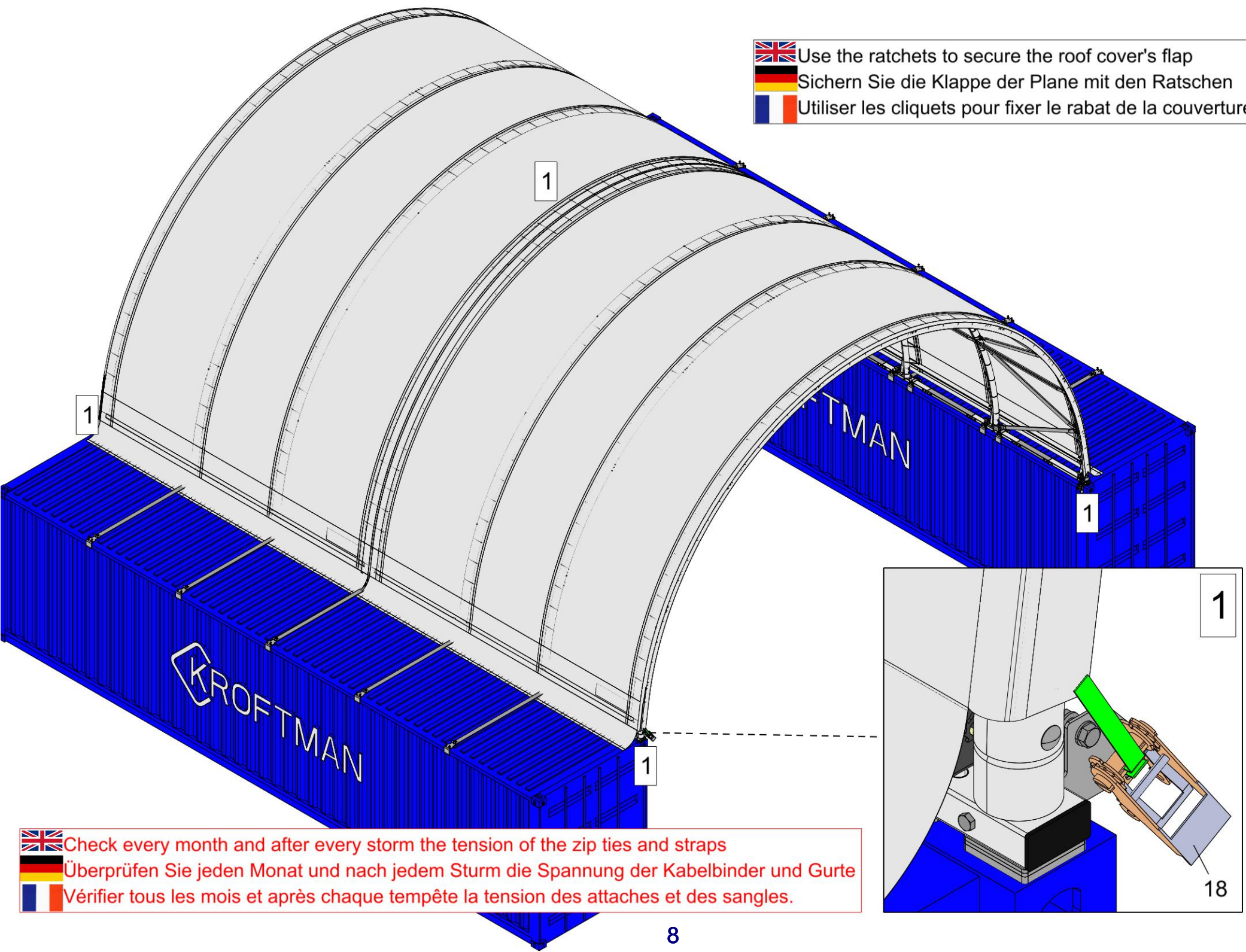

 Use the ratchets to secure the roof cover's flap  
 Sichern Sie die Klappe der Plane mit den Ratschen  
 Utiliser les cliquets pour fixer le rabat de la couverture de toit.



 Check every month and after every storm the tension of the zip ties and straps  
 Überprüfen Sie jeden Monat und nach jedem Sturm die Spannung der Kabelbinder und Gurte  
 Vérifier tous les mois et après chaque tempête la tension des attaches et des sangles.