

Container shelter/ Containerüberdachung / Abris sur containers



# KROFTMAN CT-S-1000

Assembly manual for end wall cover

Montageanleitung für Stirnwandabdeckung

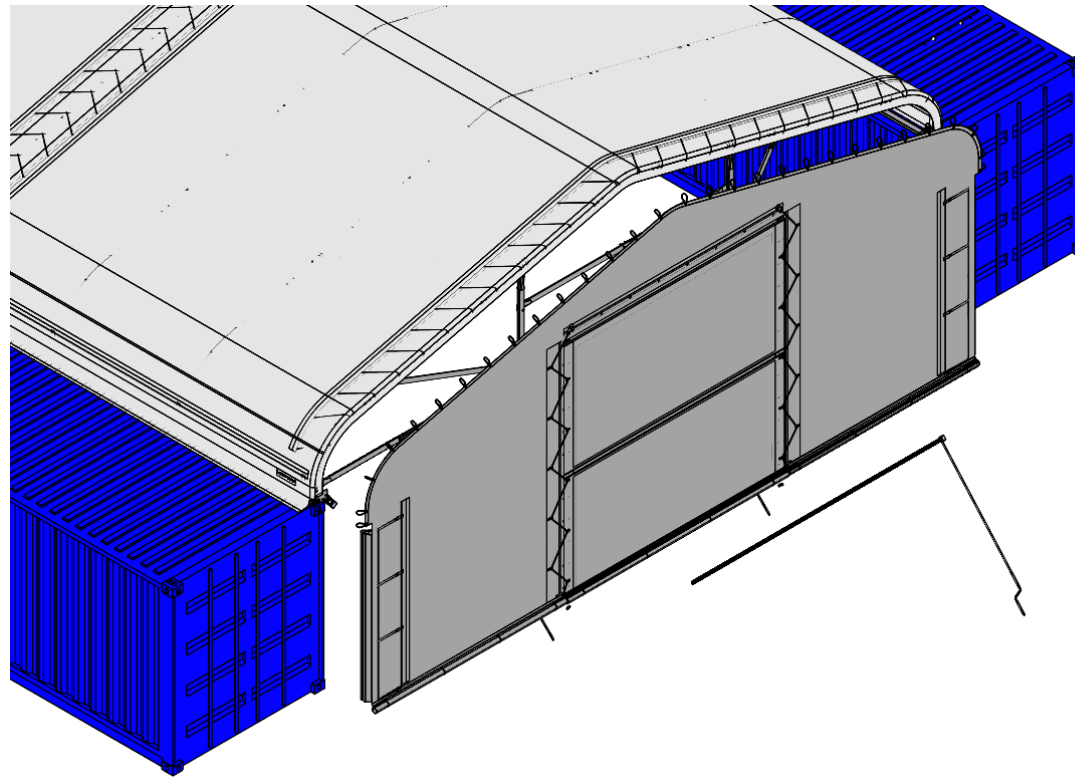
Manuel d'assemblage pour le couvercle de la paroi d'extrémité



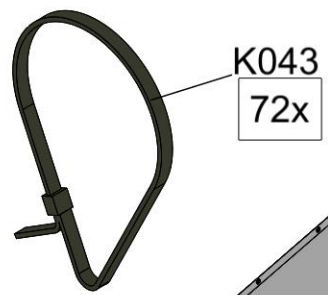
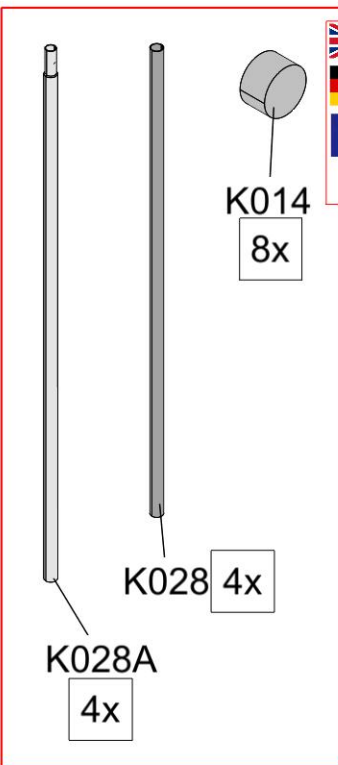

 Delivered with end wall frame crate  
 Geliefert mit Stirnwandrahmenkiste  
 Livré avec une caisse à cadre mural d'extrémité

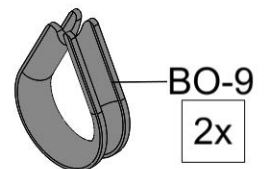
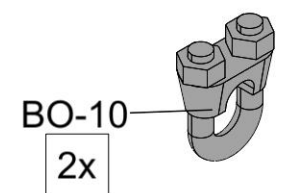

K040 1x



 Delivered in roll-up system package  
 Geliefert in einem aufgerollten Systempaket  
 Livré dans un ensemble de systèmes à enroulement

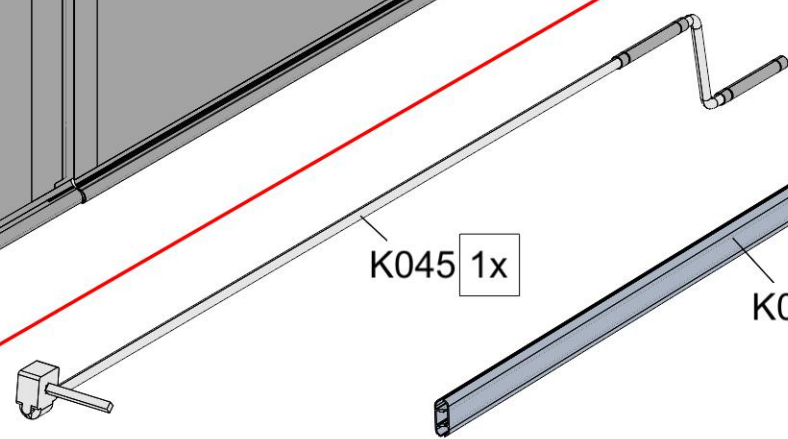
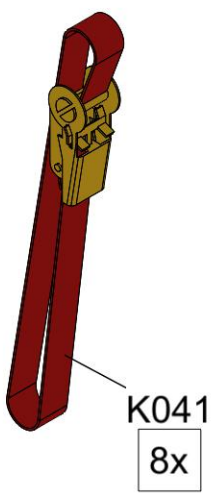

K045 1x

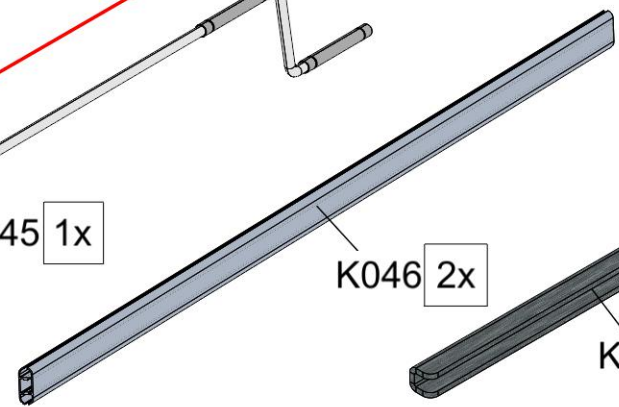



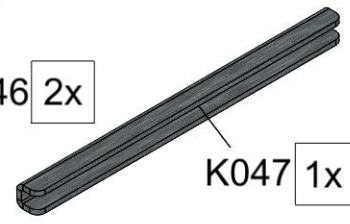

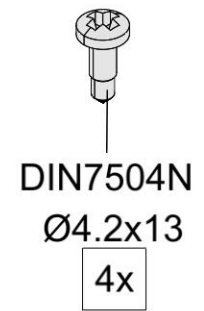

K046 2x



K047 1x



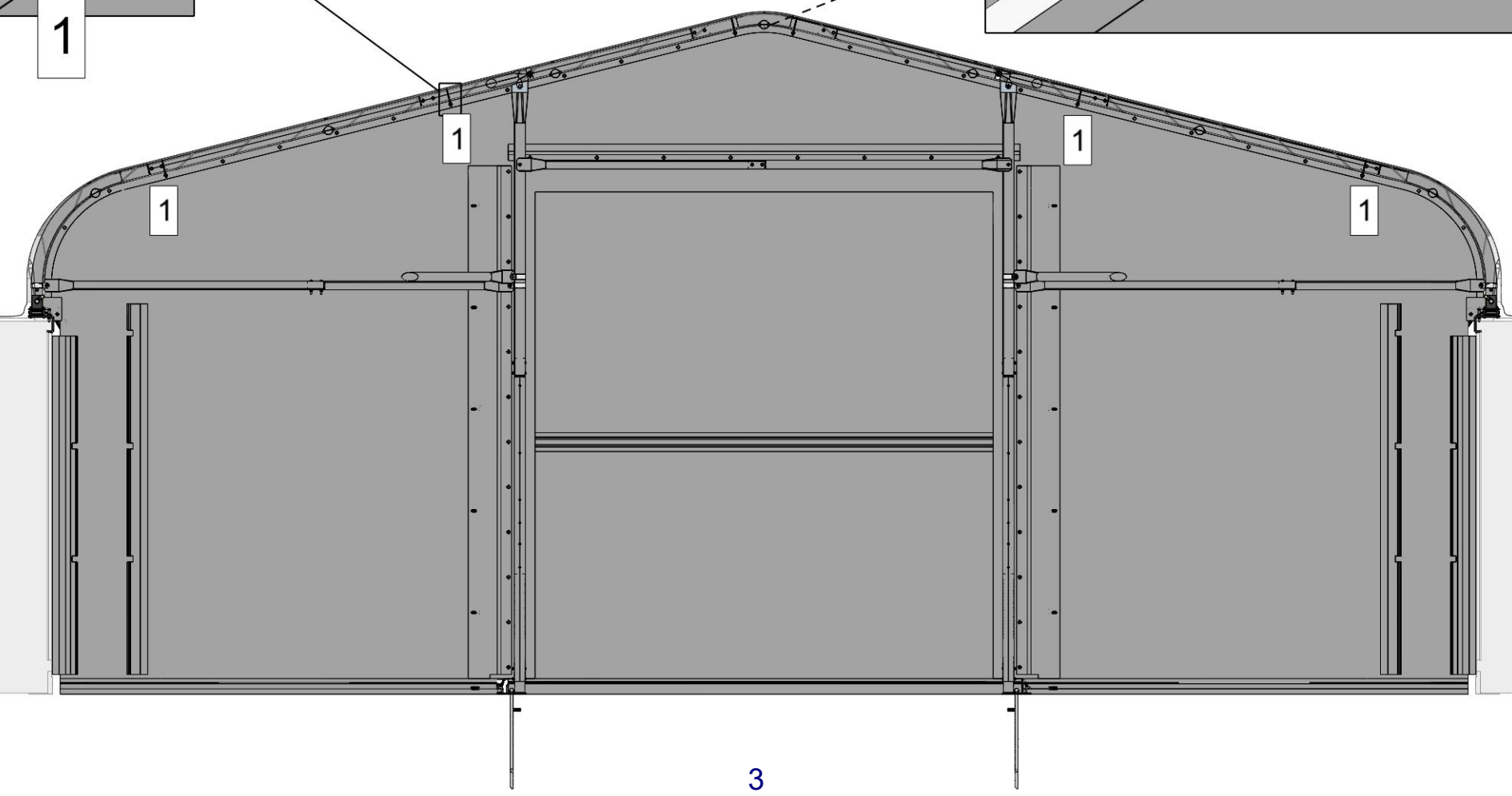
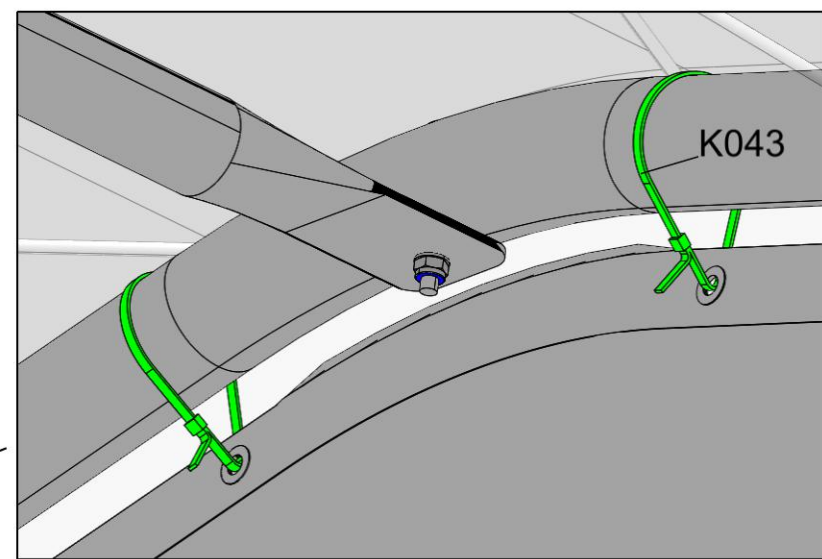
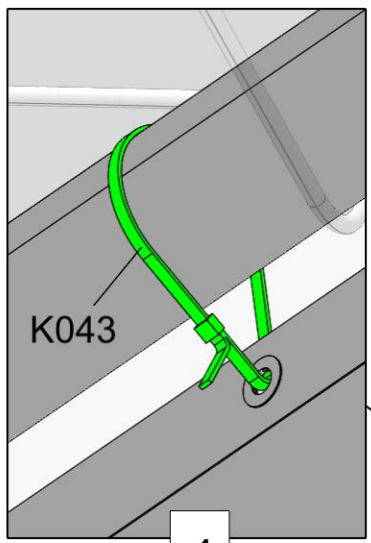

 Secure the cover here with 6 tie wraps  
 Sichern Sie die Plane hier mit 6 Kabelbindern  
 Fixer la couverture ici avec 6 attaches

 Seen from the inside  
 Von innen gesehen  
 Vu de l'intérieur

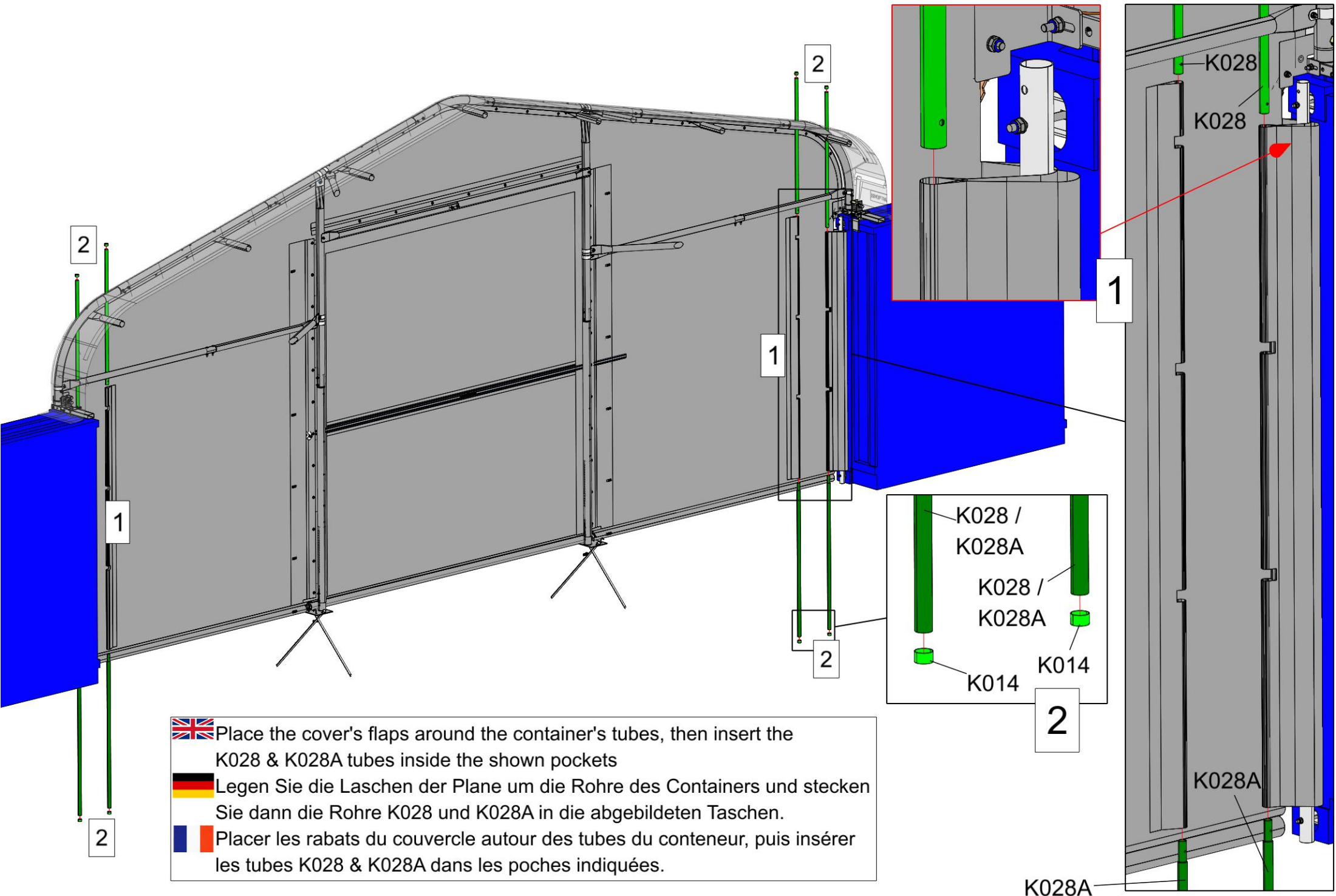





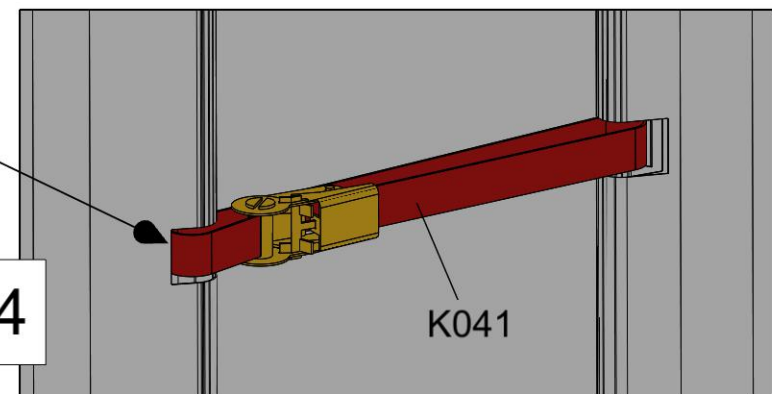
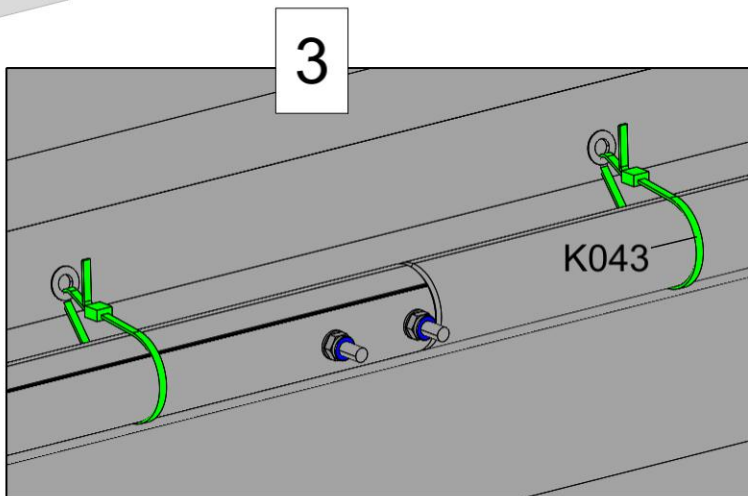
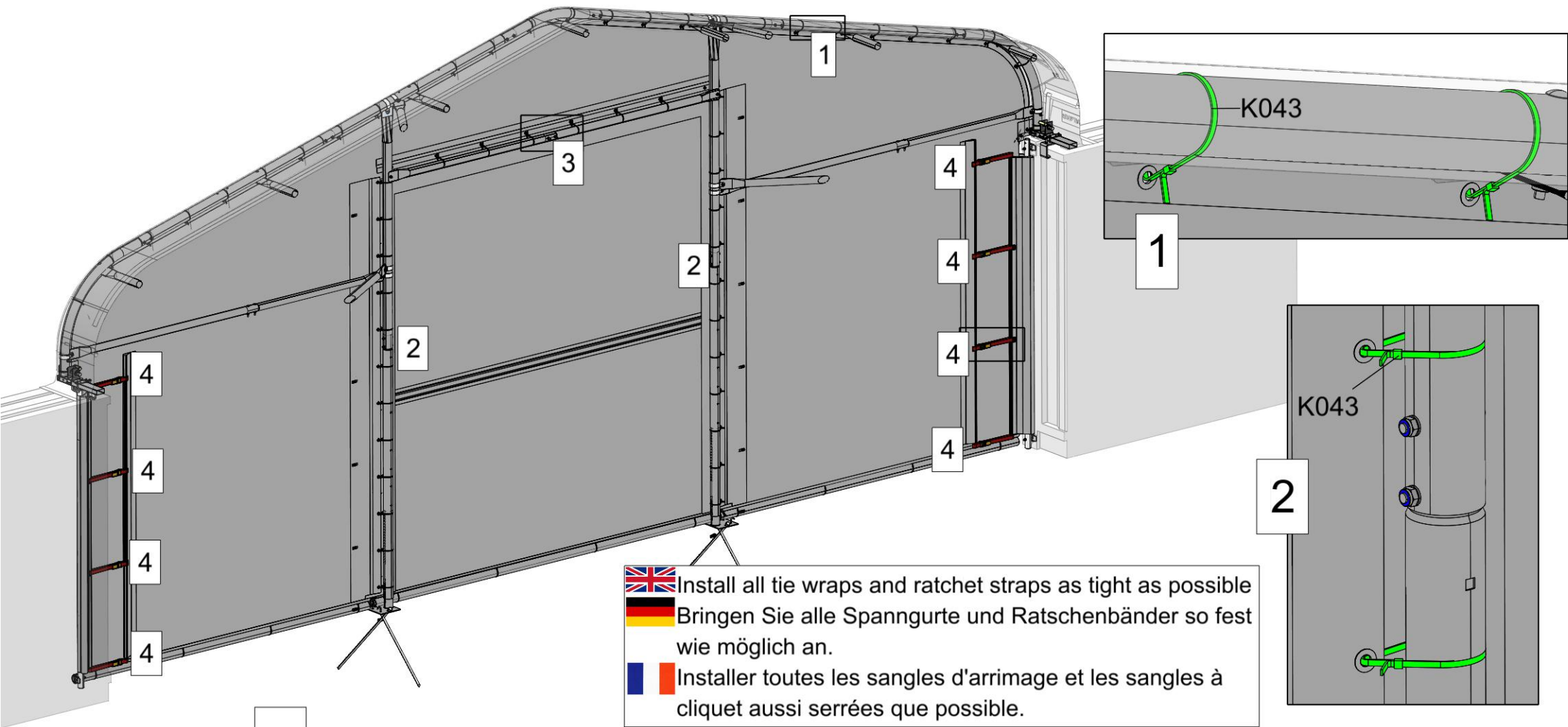

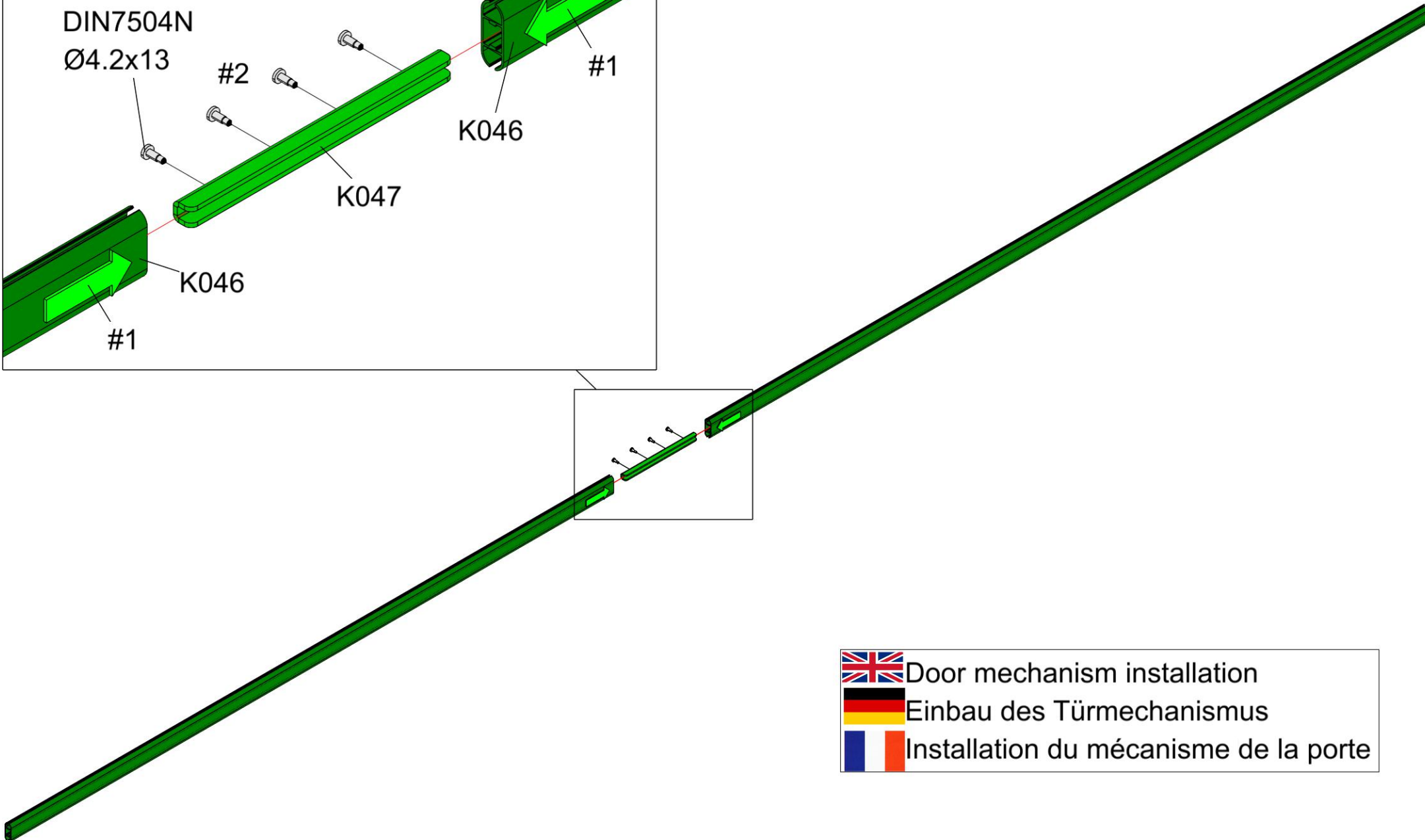
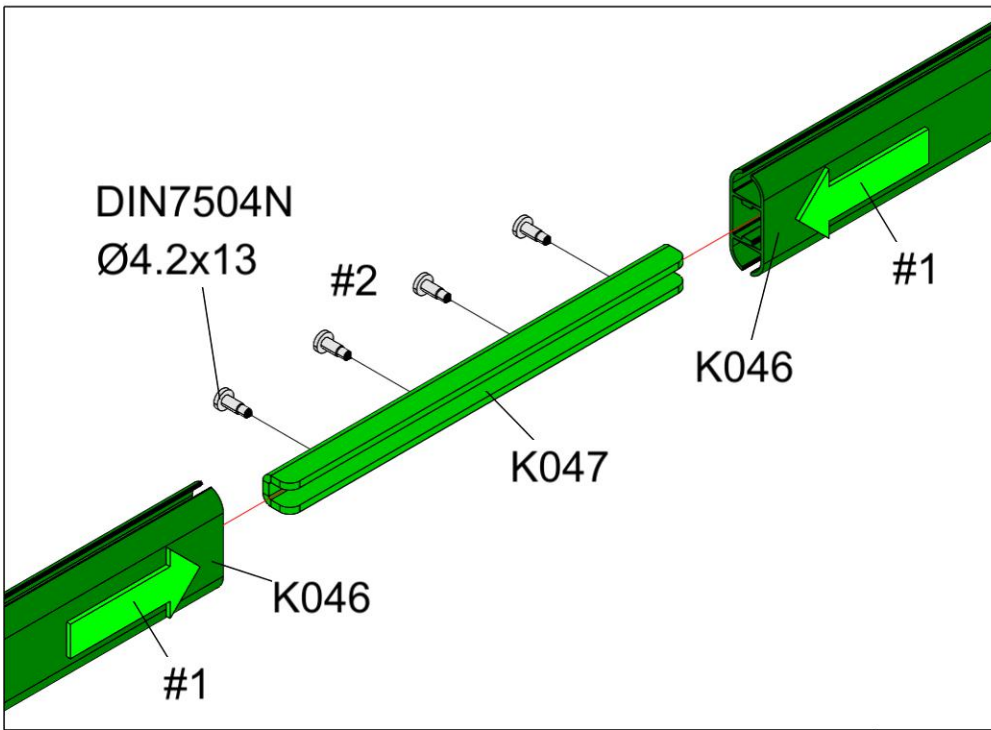

 Place the cover's flaps around the container's tubes, then insert the K028 & K028A tubes inside the shown pockets  
 Legen Sie die Laschen der Plane um die Rohre des Containers und stecken Sie dann die Rohre K028 und K028A in die abgebildeten Taschen.  
 Placer les rabats du couvercle autour des tubes du conteneur, puis insérer les tubes K028 & K028A dans les poches indiquées.





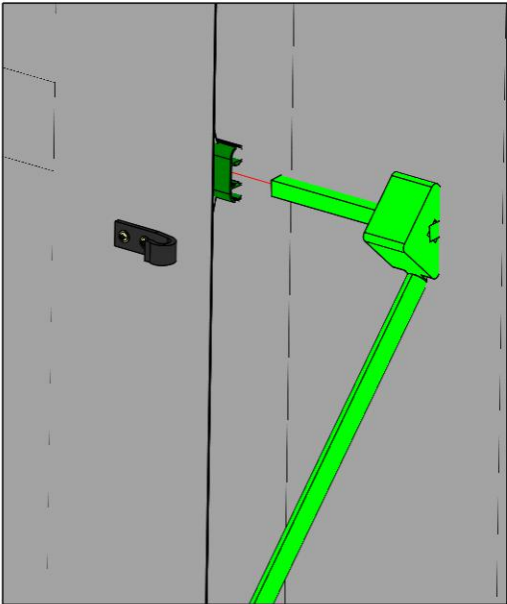
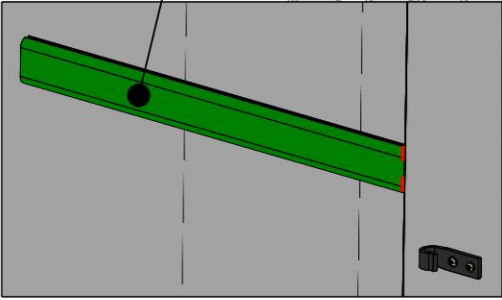

-  Door mechanism installation
-  Einbau des Türmechanismus
-  Installation du mécanisme de la porte

 Cut to size of the door  
 Zuschnitt auf die Größe  
der Tor  
 Couper à la taille de la  
porte



 Insert the door mechanism through its special pocket in the door  
and attach the handle.  
 Führen Sie den Türmechanismus in die dafür vorgesehene Tasche  
in der Tür ein und befestigen Sie den Griff.  
 Insérez le mécanisme de la porte dans la poche prévue à cet effet  
dans la porte et fixez la poignée.

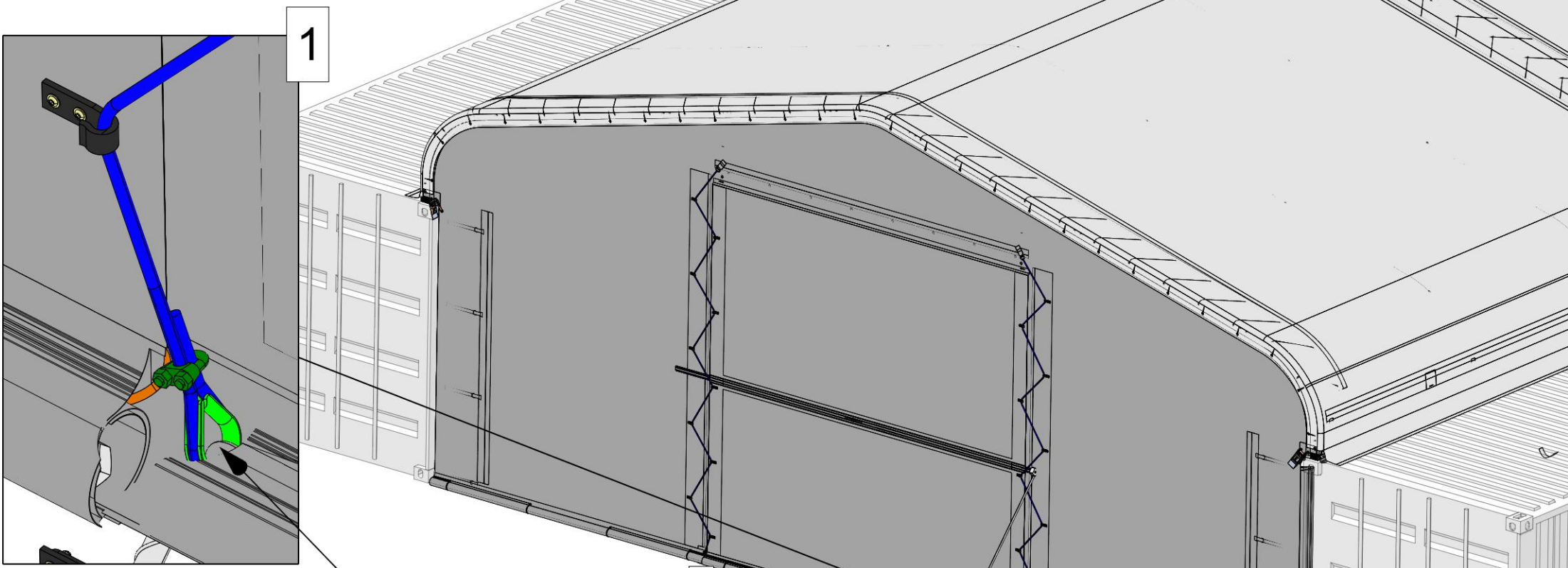



1

1

1

 Use the attached nylon ropes to tie the door cover to the base plate hooks

 Befestigen Sie die Tor mit den beiliegenden Nylonseilen an den Haken der Grundplatte.

 Utilisez les cordes en nylon jointes pour attacher le couvercle de la porte aux crochets de la plaque de base.

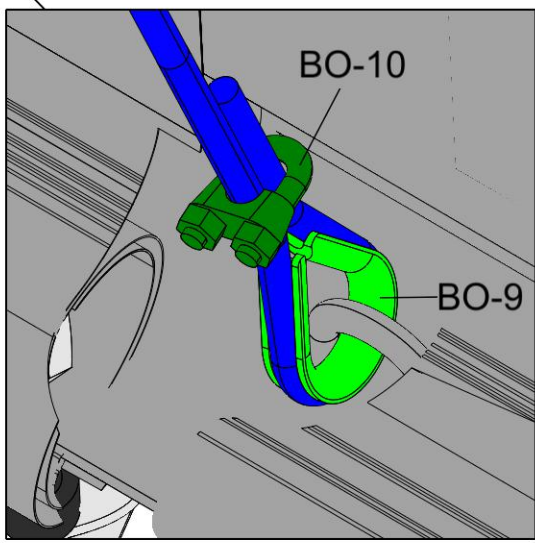

BO-10

BO-9

 Roll-up the excess cover.

 Rollen Sie die überflüssige Plane auf.

 Enrouler l'excédent de couverture.

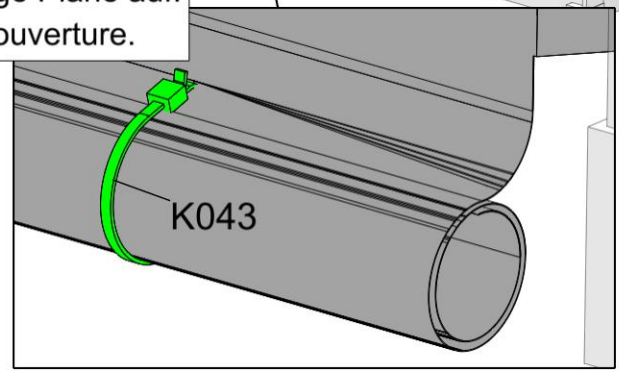

K043