

Container shelter/ Containerüberdachung / Abris sur containers

KROFTMAN CT-S-1012

Assembly manual for main frame
Montageanleitung für den Hauptrahmen
Manuel d'assemblage du cadre principal

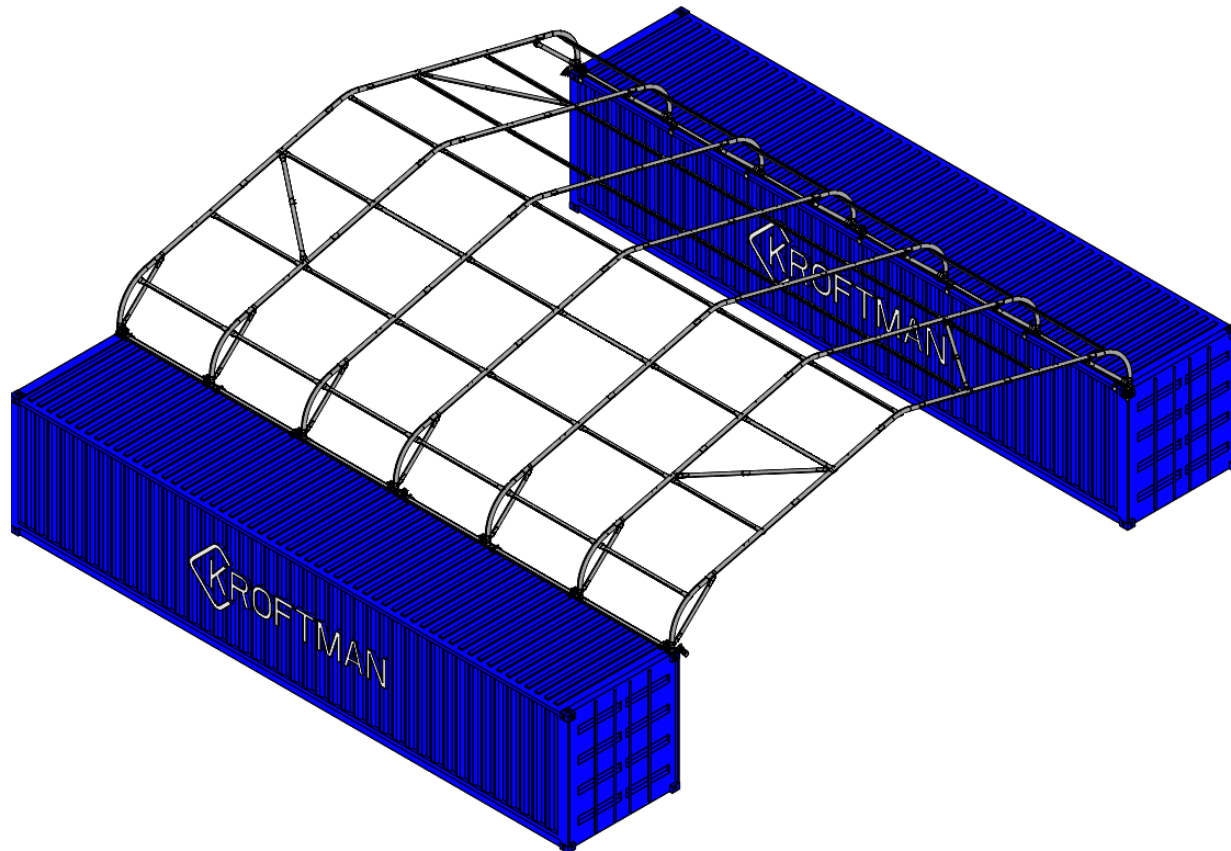

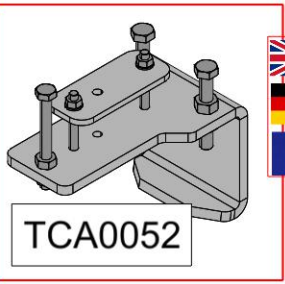

TCA0052

 Extra option
 Zusätzliche Option
 Option supplémentaire

K004 7x



K011 16x

28x
K005

K009 8x

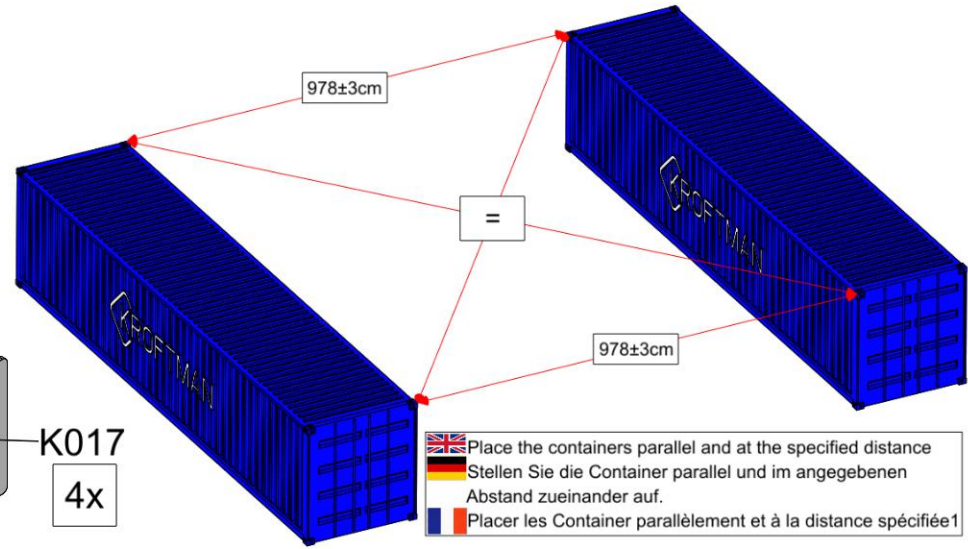
K017 4x



 Place the containers parallel and at the specified distance
 Stellen Sie die Container parallel und im angegebenen Abstand zueinander auf.
 Placer les Container parallèlement et à la distance spécifiée1

K015 4x

14x
K003

K008 20x

BO-2 49x
 DIN985 M10
 DIN125A
 DIN603 M10x100

BO-3 80x
 DIN985 M10
 DIN125A
 DIN931 M10x110

25B 4x

18 4x



BO-4 36x
 DIN985 M10
 DIN125A
 DIN933 M10x40

BO-1 120x
 DIN985 M10
 DIN125A
 DIN603 M10x90

K177 14x

K030 36x

BO-7 4x
 DIN985 M10
 DIN125A
 DIN933 M10x25

 Need for cover assembly
 Erforderlich für die Montage der Plane
 Nécessité d'assembler le couvercle

25A 4x

42x
K007

K014 4x

2x K013

K002 2x

K001 10x

10x K012

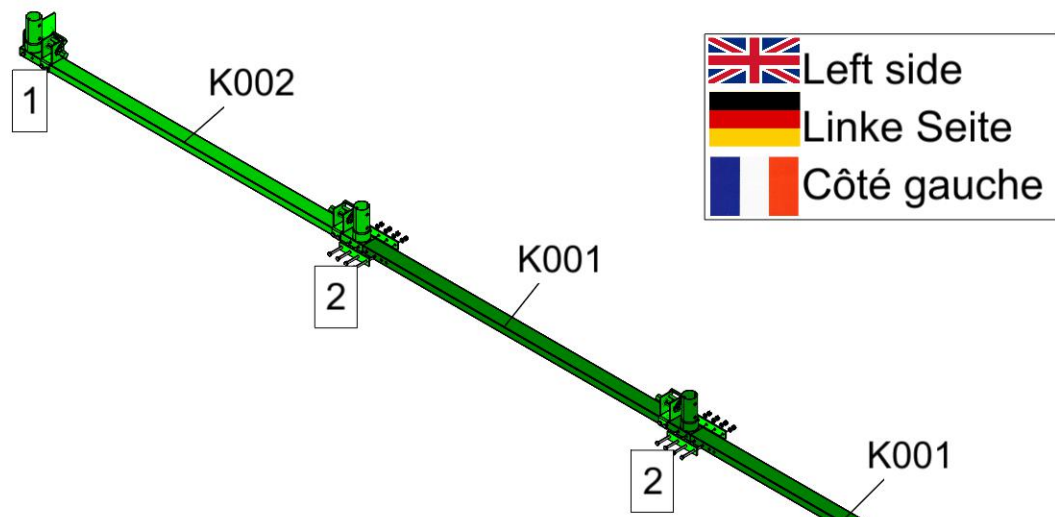

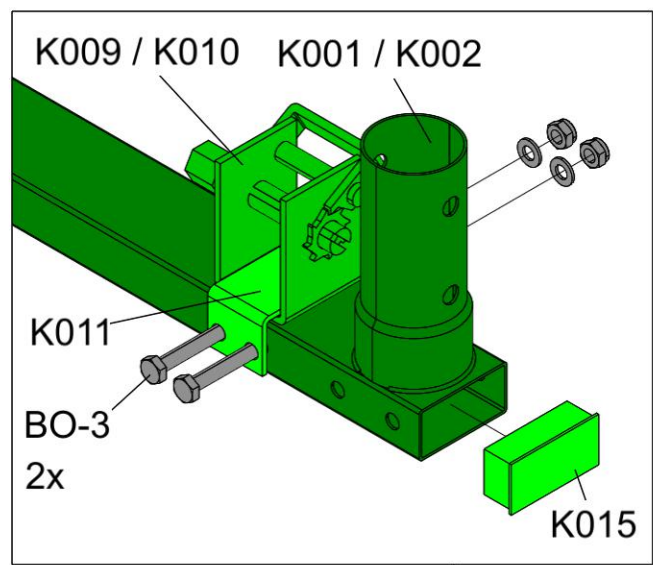

 Left side
 Linke Seite
 Côté gauche

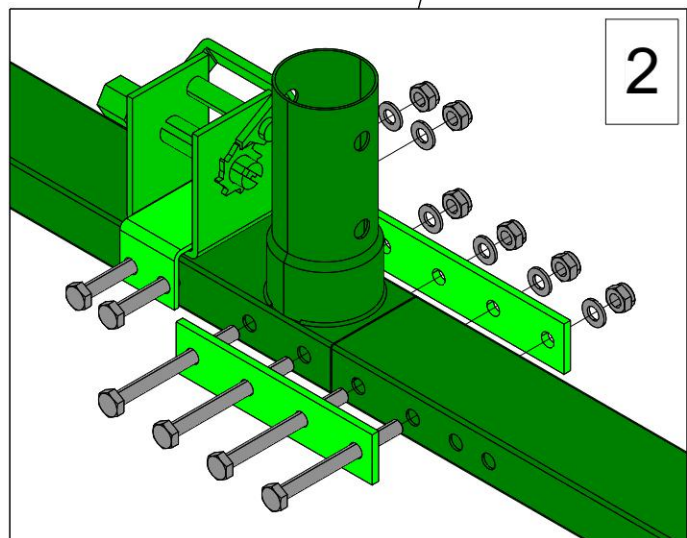
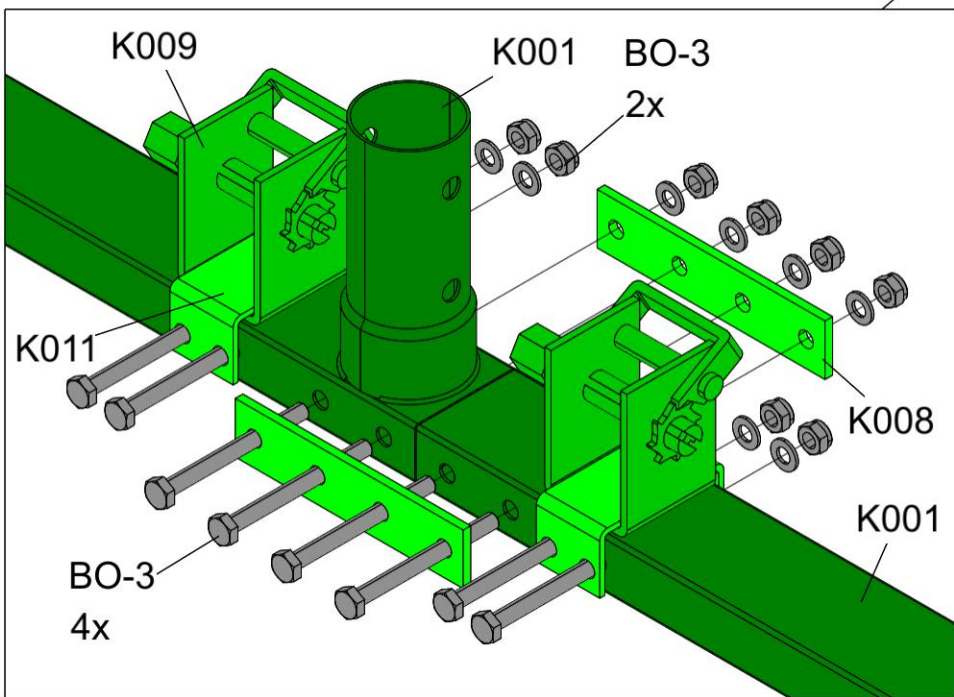

 The right side base rail is mirrored
 Die rechte Grundschiene ist gespiegelt
 Le rail de la base droite est en miroir





 Place and symmetrically align the base rail on top of the container. Mark the position of the TCA0008 / TCA0052 clamps as close to the tubes as possible, remove the base rail and place the clamps. Level the clamps and tighten the nuts hand-tight.

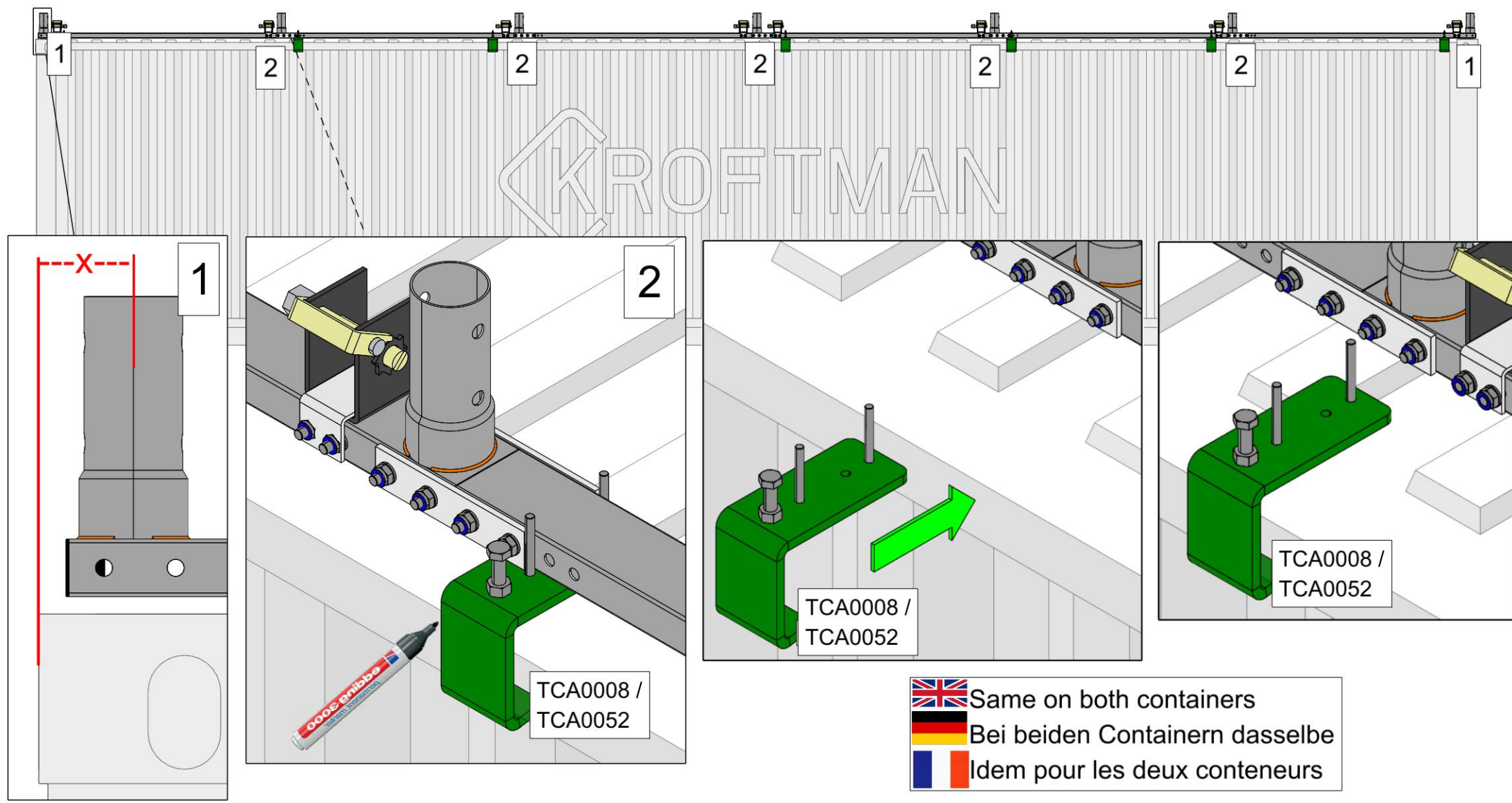

 Setzen Sie die Grundschiene auf den Container und richten Sie sie symmetrisch aus. Die Position der TCA0008 / TCA0052-Klemmen so nah wie möglich an den Rohren markieren, die Grundschiene entfernen und die Klemmen anbringen. Richten Sie die Klemmen aus und ziehen Sie die Muttern handfest an.

 Placer et aligner symétriquement le rail de base sur le dessus du conteneur. Marquer la position des pinces TCA0008 / TCA0052 le plus près possible des tubes, retirer le rail de base et placer les pinces. Mettez les pinces à niveau et serrez les écrous à la main.

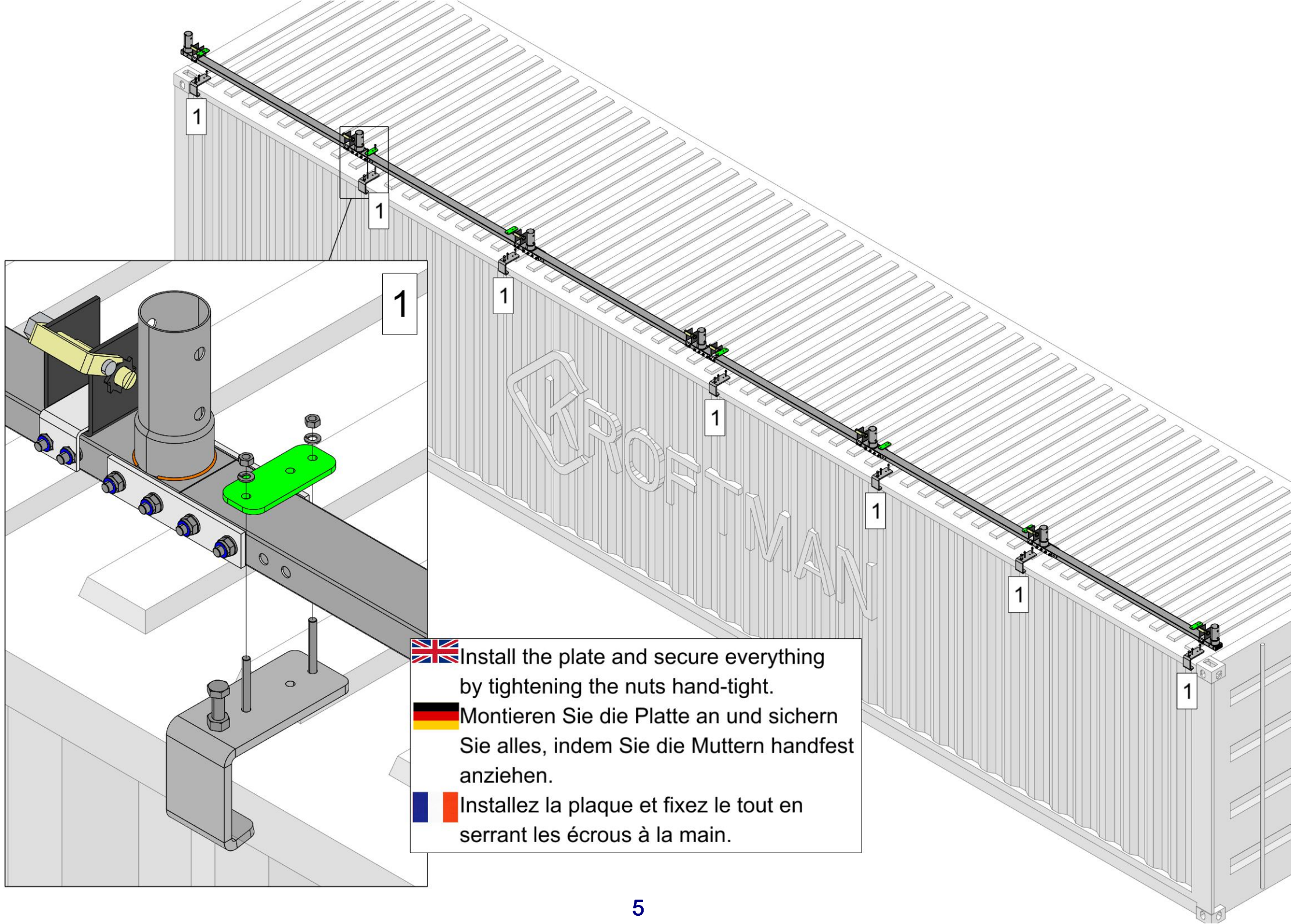

 Same on both containers
 Bei beiden Containern dasselbe
 Idem pour les deux conteneurs



-  Install the plate and secure everything by tightening the nuts hand-tight.
-  Montieren Sie die Platte an und sichern Sie alles, indem Sie die Muttern handfest anziehen.
-  Installez la plaque et fixez le tout en serrant les écrous à la main.

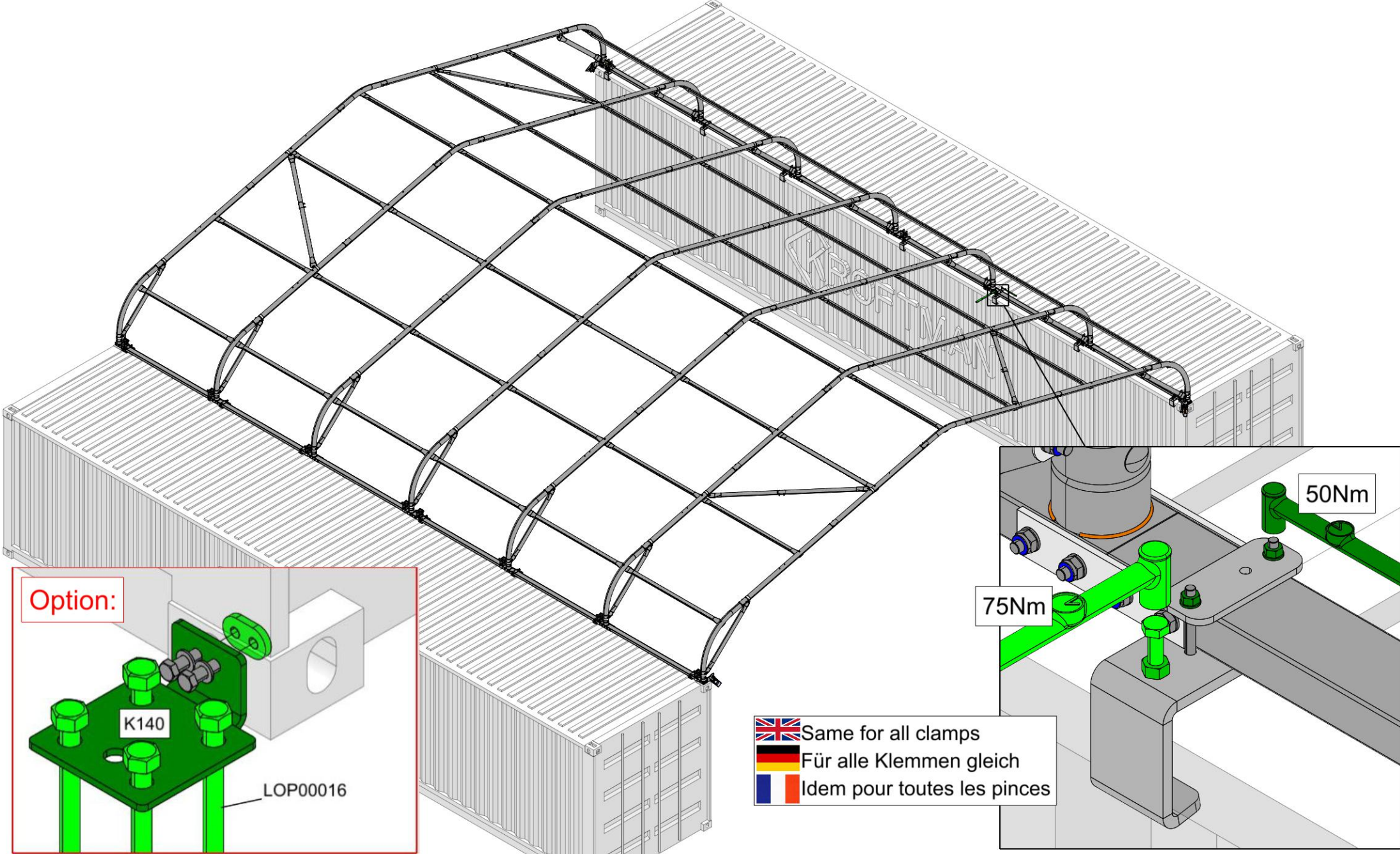



Option:



K140

LOP00016

75Nm

50Nm

 Same for all clamps
 Für alle Klemmen gleich
 Idem pour toutes les pinces

 Important: add permanent weight in containers according to calculations or use optional container anchoring bracket.
 Wichtig: Fügen Sie den Containern ein dauerhaftes Gewicht gemäß den Berechnungen hinzu oder verwenden Sie die optionalen Container- Verankerungsklemmen.
 Important : ajoutez le poids permanent dans les conteneurs selon les calculs ou utilisez le support d'ancrage de conteneur en option.