

KROFTMAN CT-S-1500

Assembly manual for end wall frame

Montageanleitung für Stirnwandrahmen

Manuel d'assemblage pour le cadre mural d'extrémité

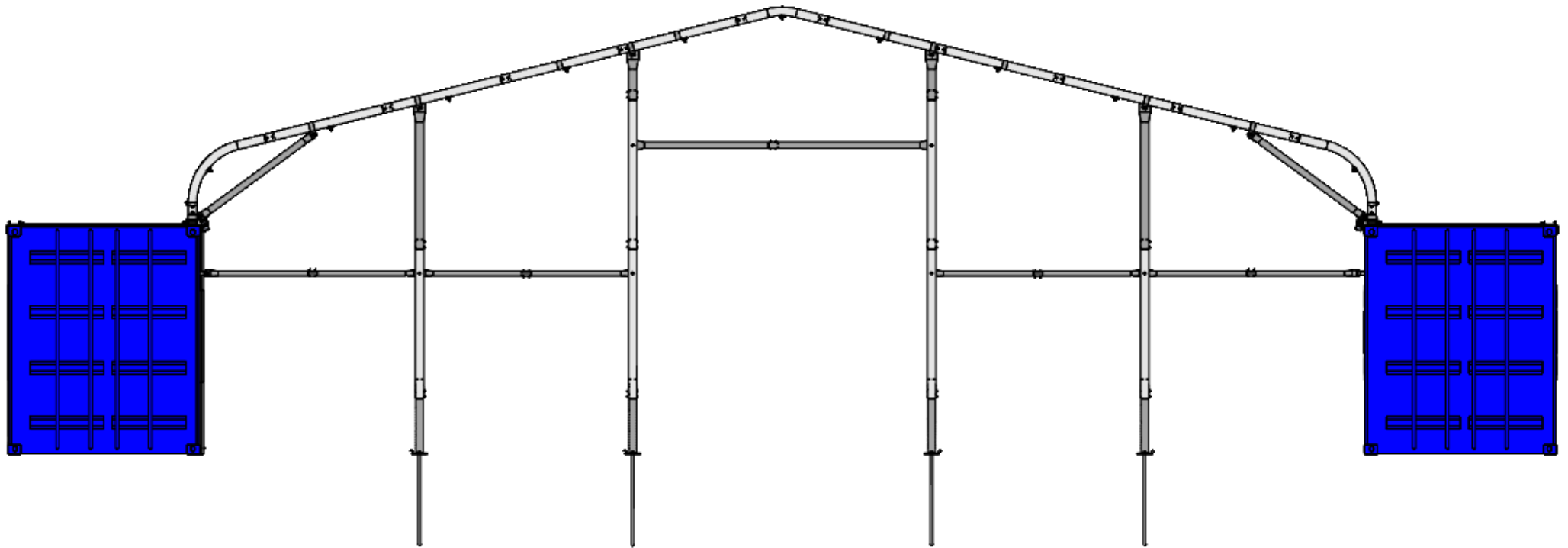

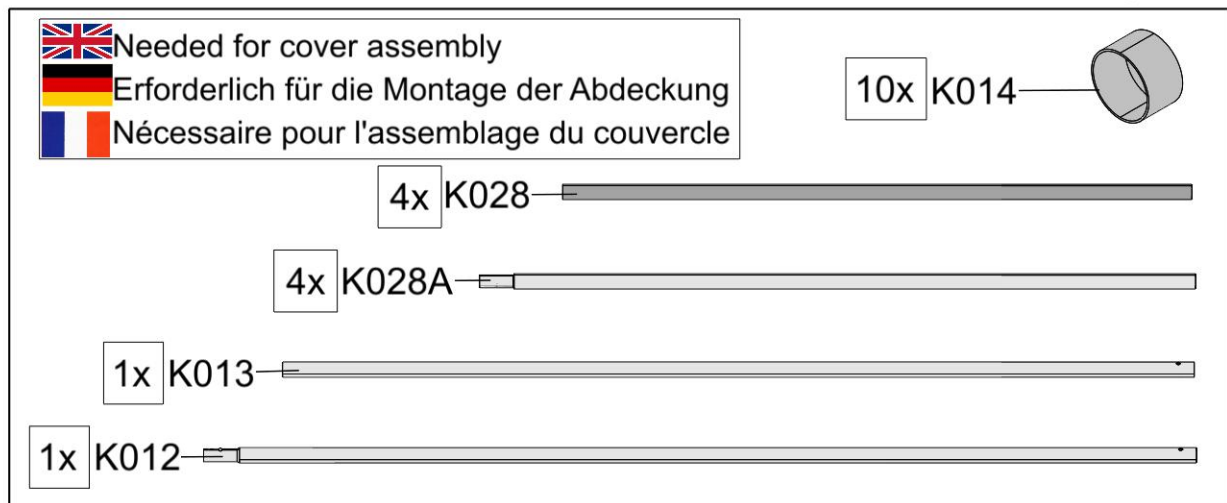
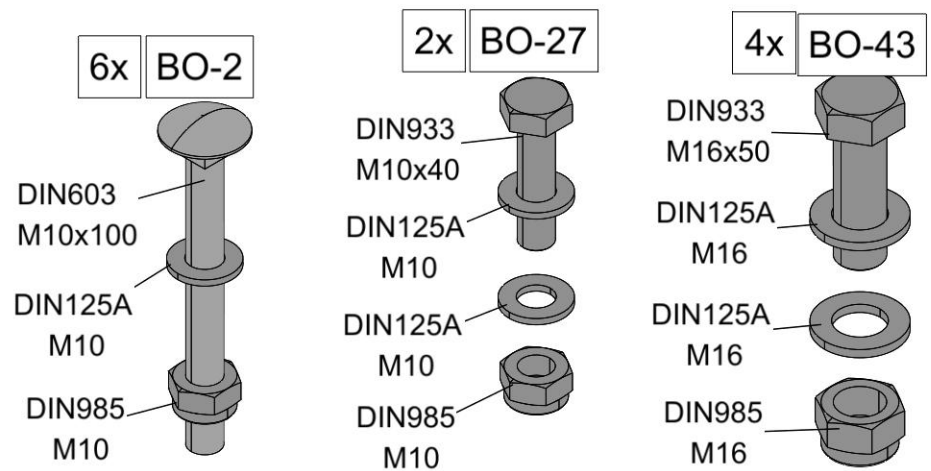
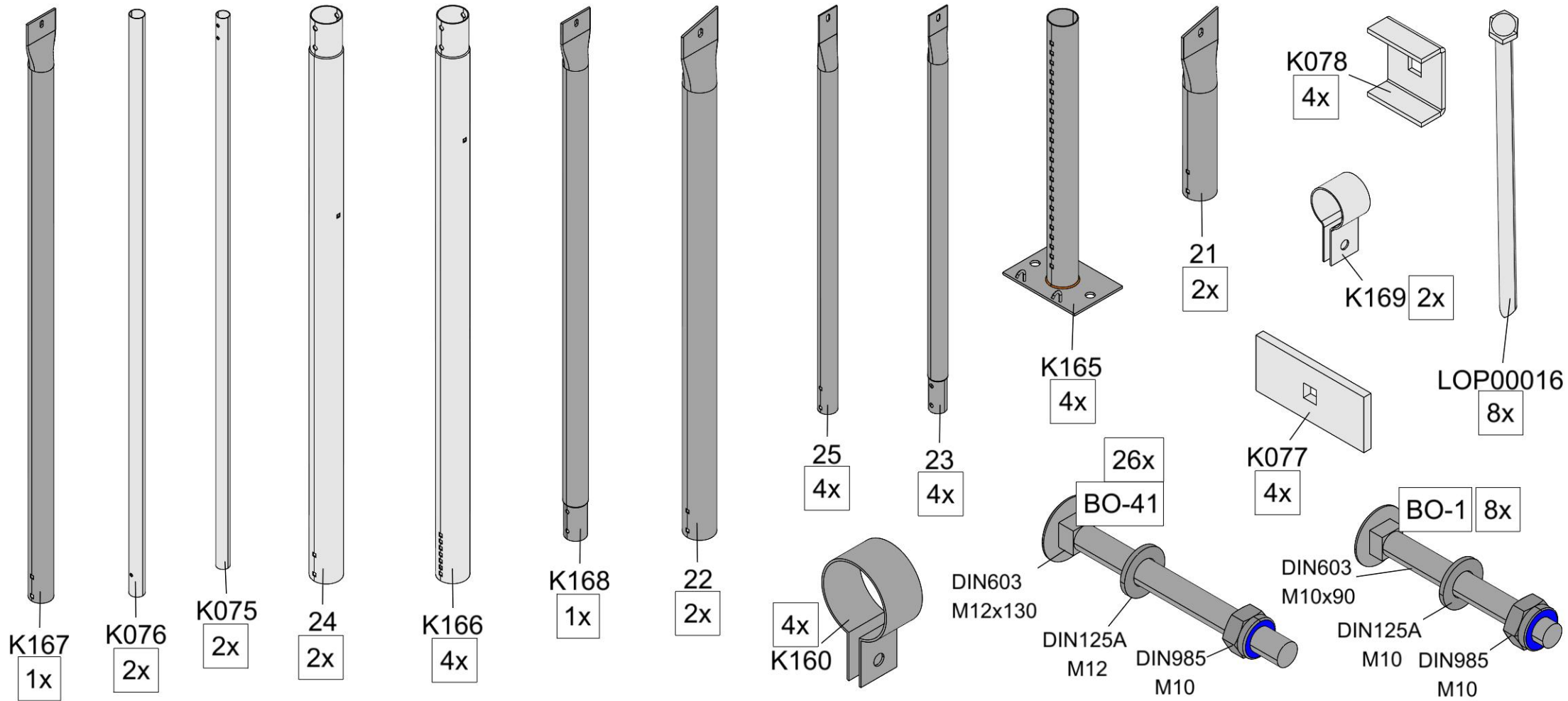

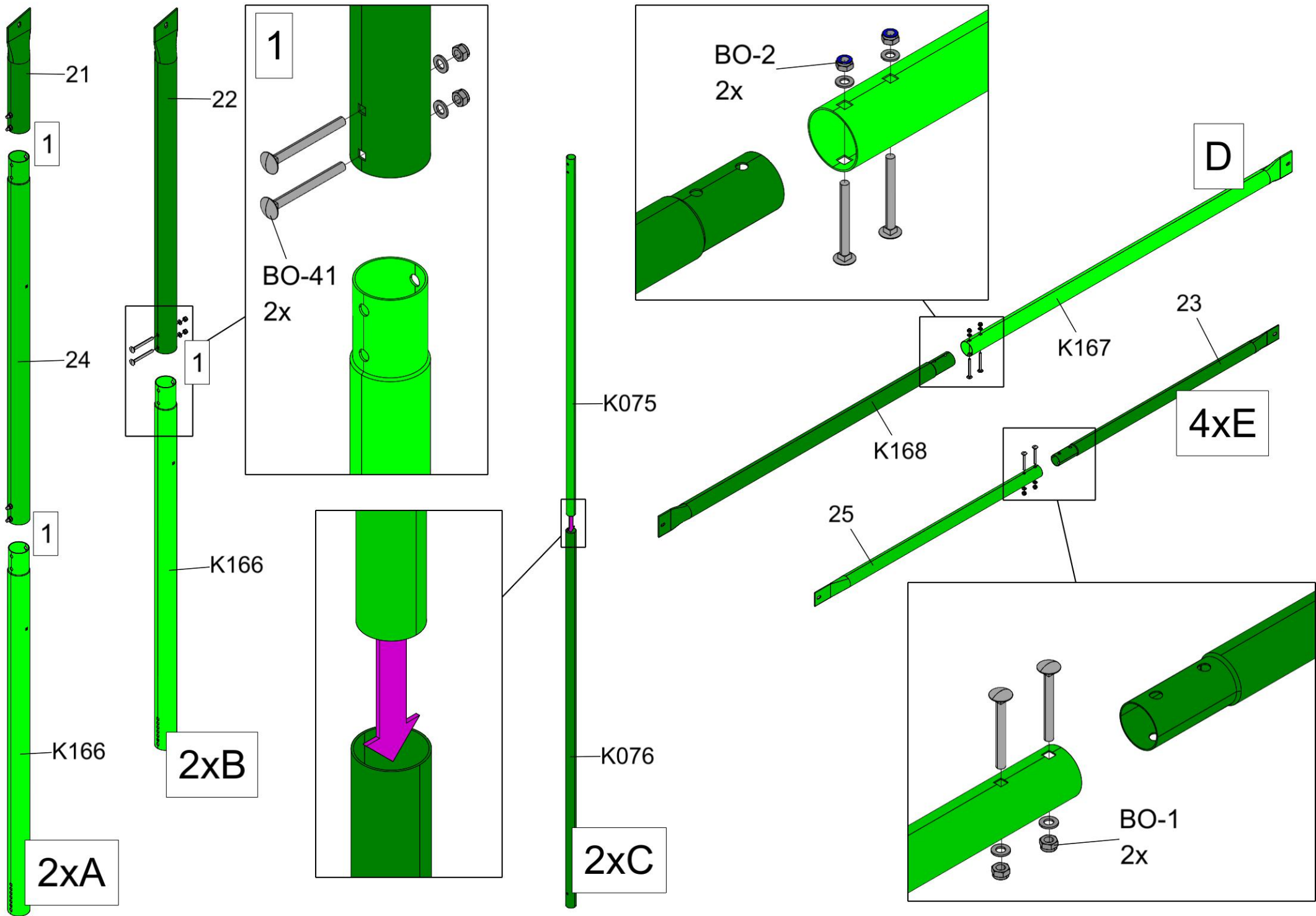

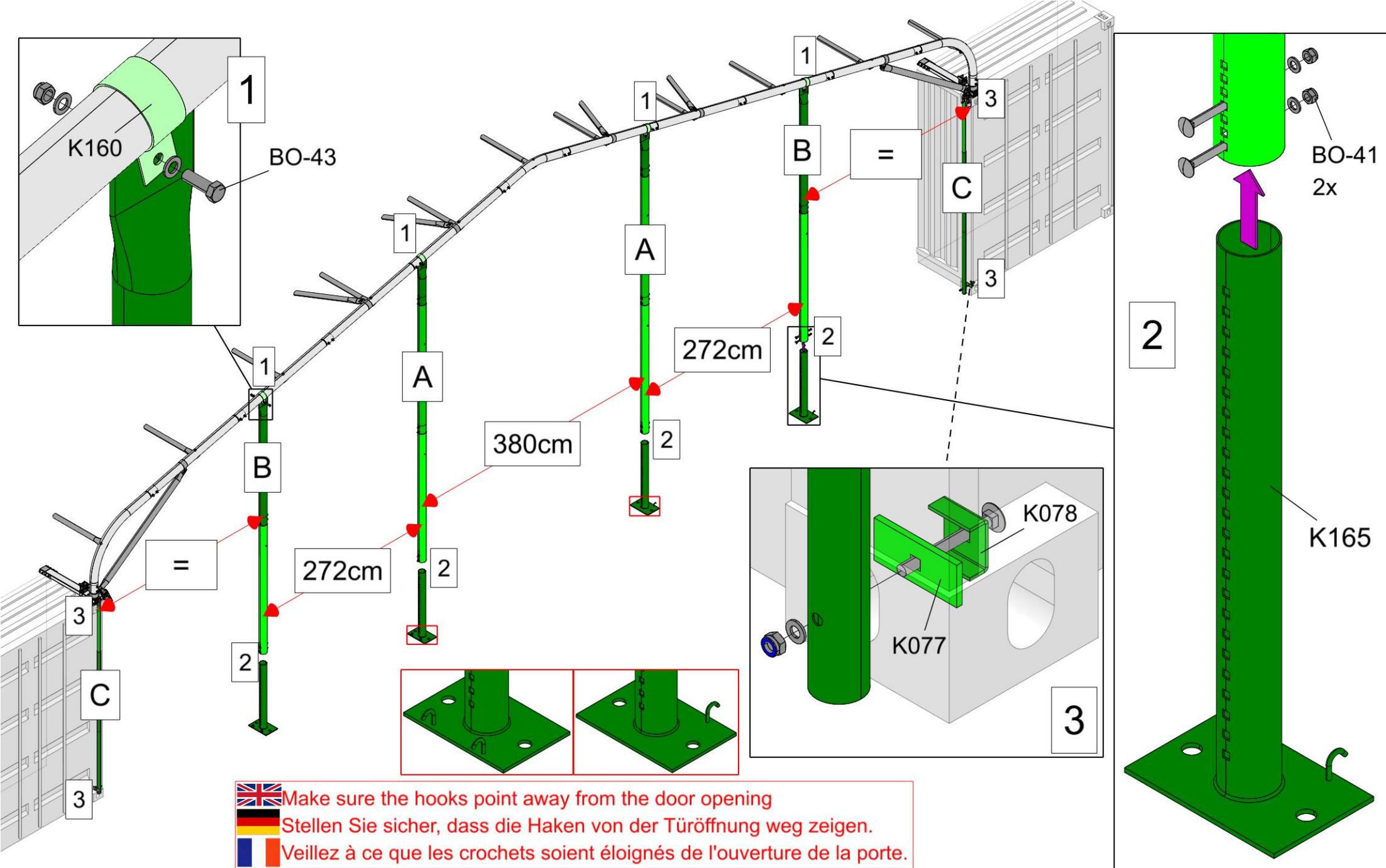

- Hang the columns to the arch with K160 clamps at the specified dimensions and insert the bottom part (K165).
- Hängen Sie die Säulen mit den Klammern K160 in den angegebenen Maßen an den Bogen und setzen Sie das Unterteil (K165) ein.
- Accrocher les colonnes à l'arc avec les pinces K160 aux dimensions spécifiées et insérer la partie inférieure (K165).

