

Container shelter/ Containerüberdachung / Abris sur containers

KROFTMAN CT-S-806

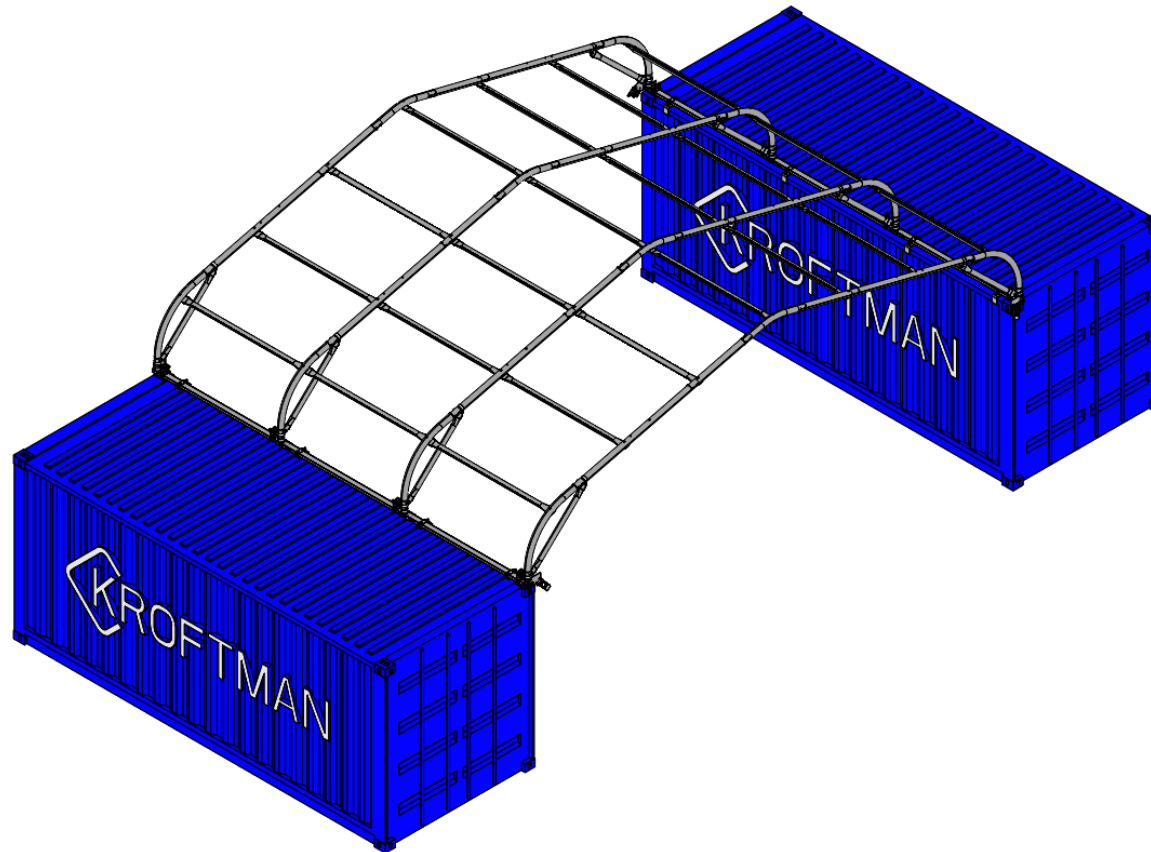

Assembly manual for main frame
Montageanleitung für den Hauptrahmen
Manuel d'assemblage du cadre principal

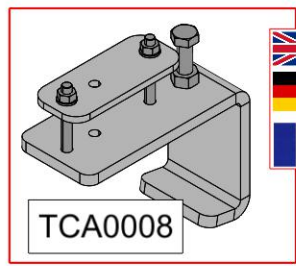



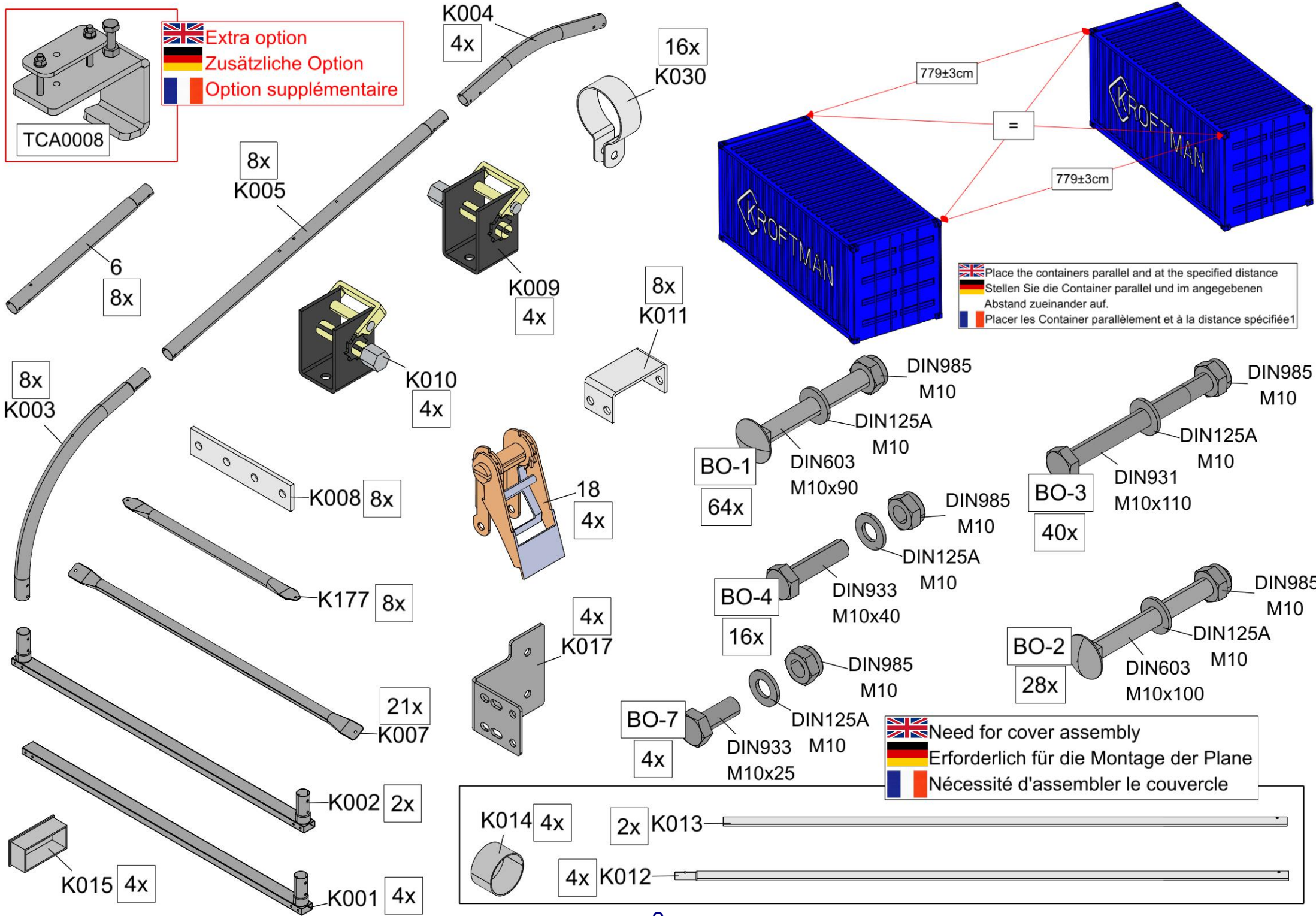

 Extra option
 Zusätzliche Option
 Option supplémentaire





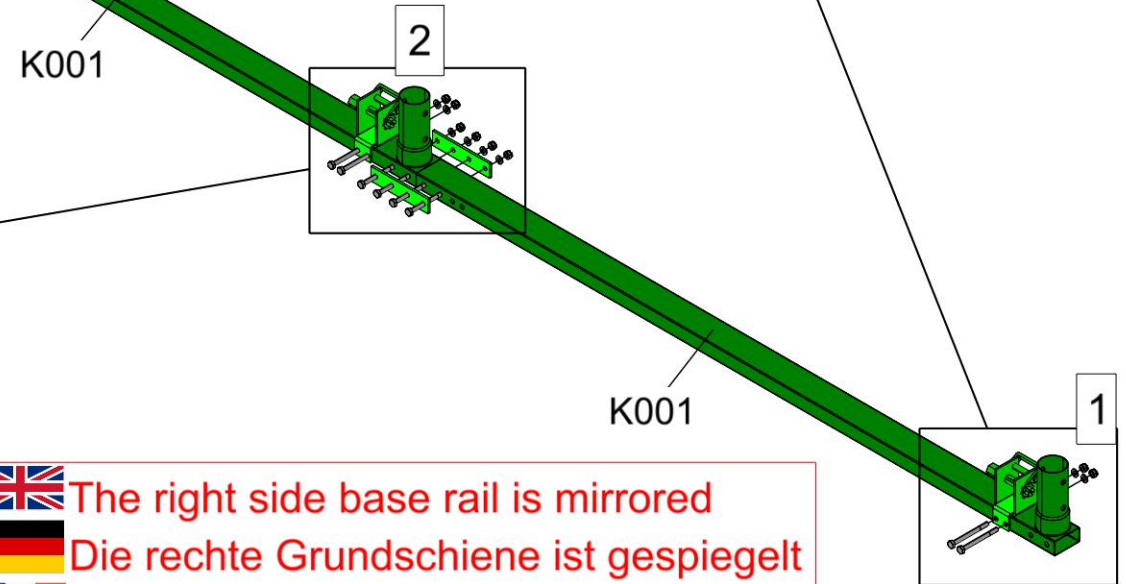
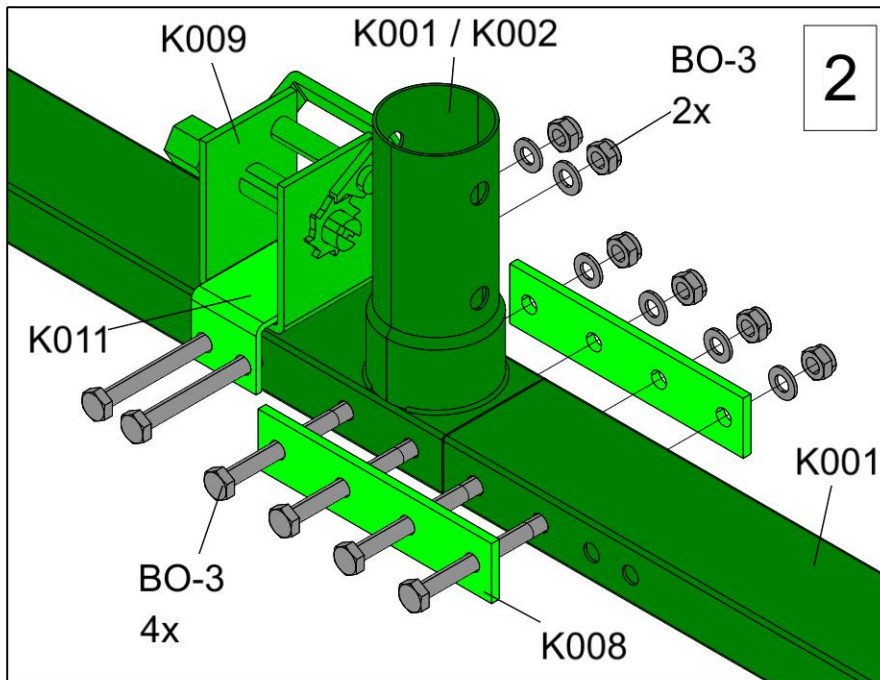
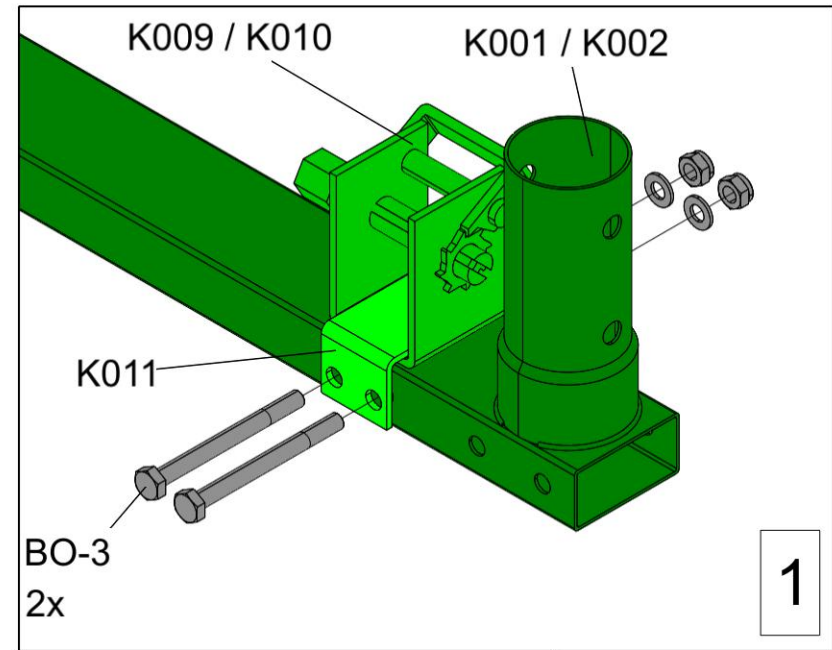
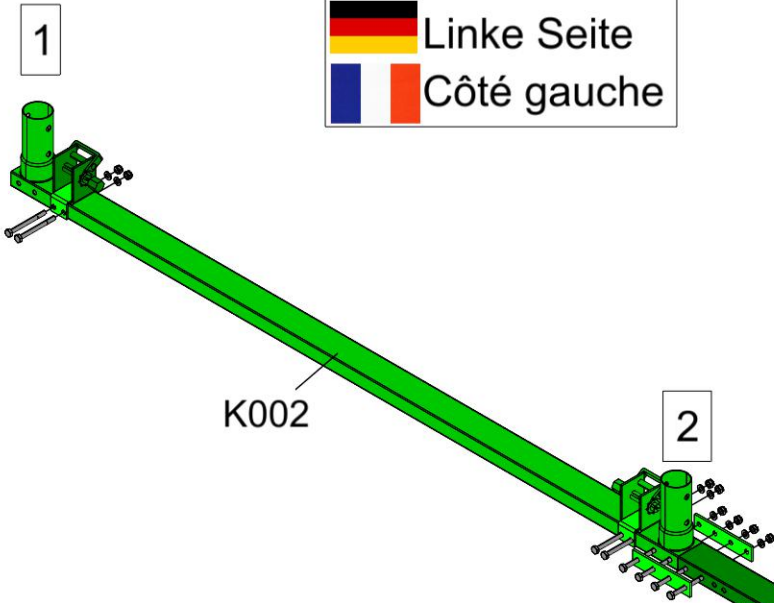

 Place the containers parallel and at the specified distance
 Stellen Sie die Container parallel und im angegebenen Abstand zueinander auf.
 Placer les Container parallèlement et à la distance spécifiée

 Need for cover assembly
 Erforderlich für die Montage der Plane
 Nécessité d'assembler le couvercle

 Left side
 Linke Seite
 Côté gauche



 The right side base rail is mirrored
 Die rechte Grundschiene ist gespiegelt
 Le rail de la base droite est en miroir



 Place and symmetrically align the base rail on top of the container. Mark the position of the TCA0008 clamps as close to the tubes as possible, remove the base rail and place the clamps. Level the clamps and tighten the nuts hand-tight.

 Setzen Sie die Grundschiene auf den Container und richten Sie sie symmetrisch aus. Die Position der TCA0008-Klemmen so nah wie möglich an den Rohren markieren, die Grundschiene entfernen und die Klemmen anbringen. Richten Sie die Klemmen aus und ziehen Sie die Muttern handfest an.

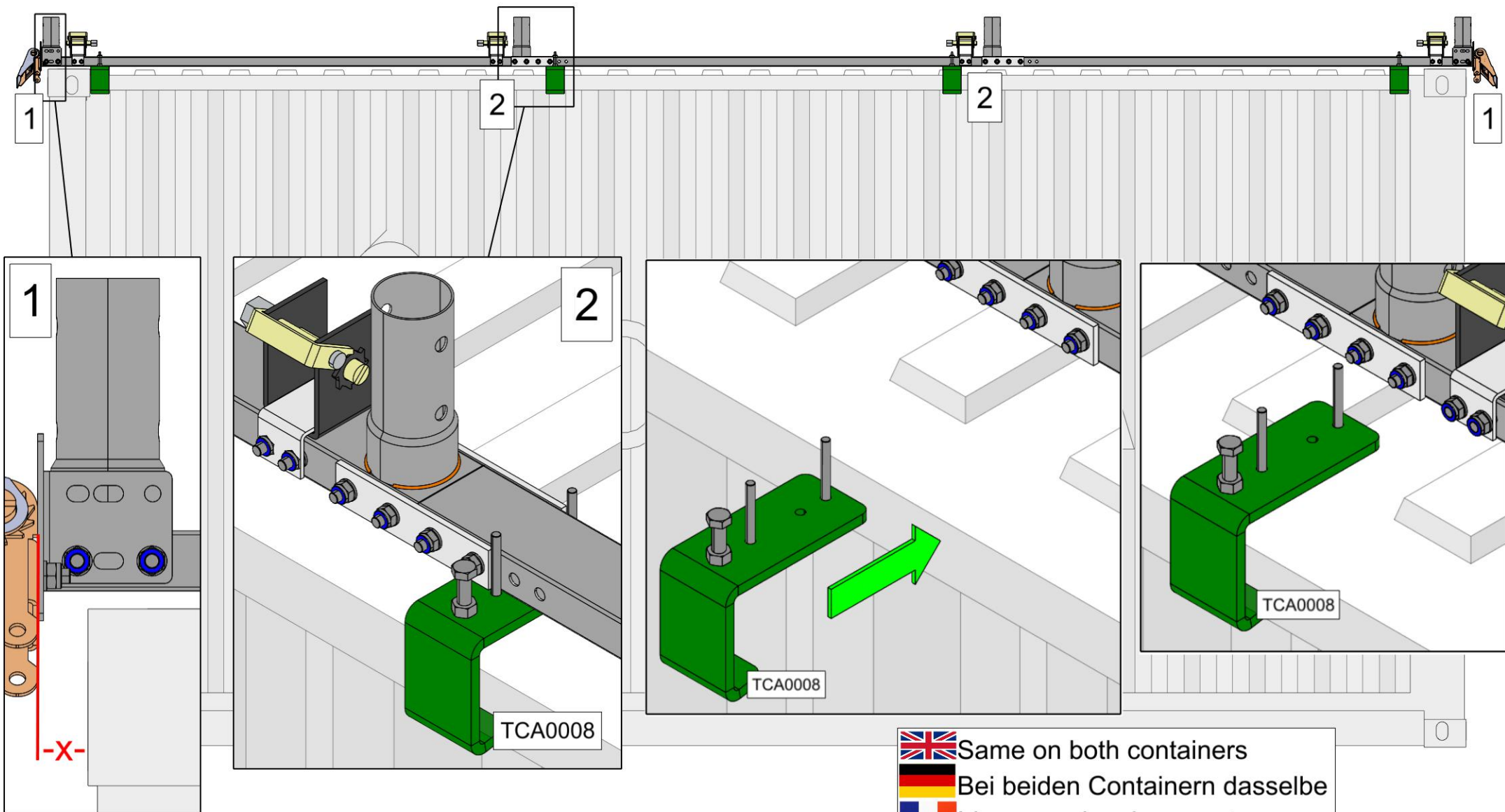

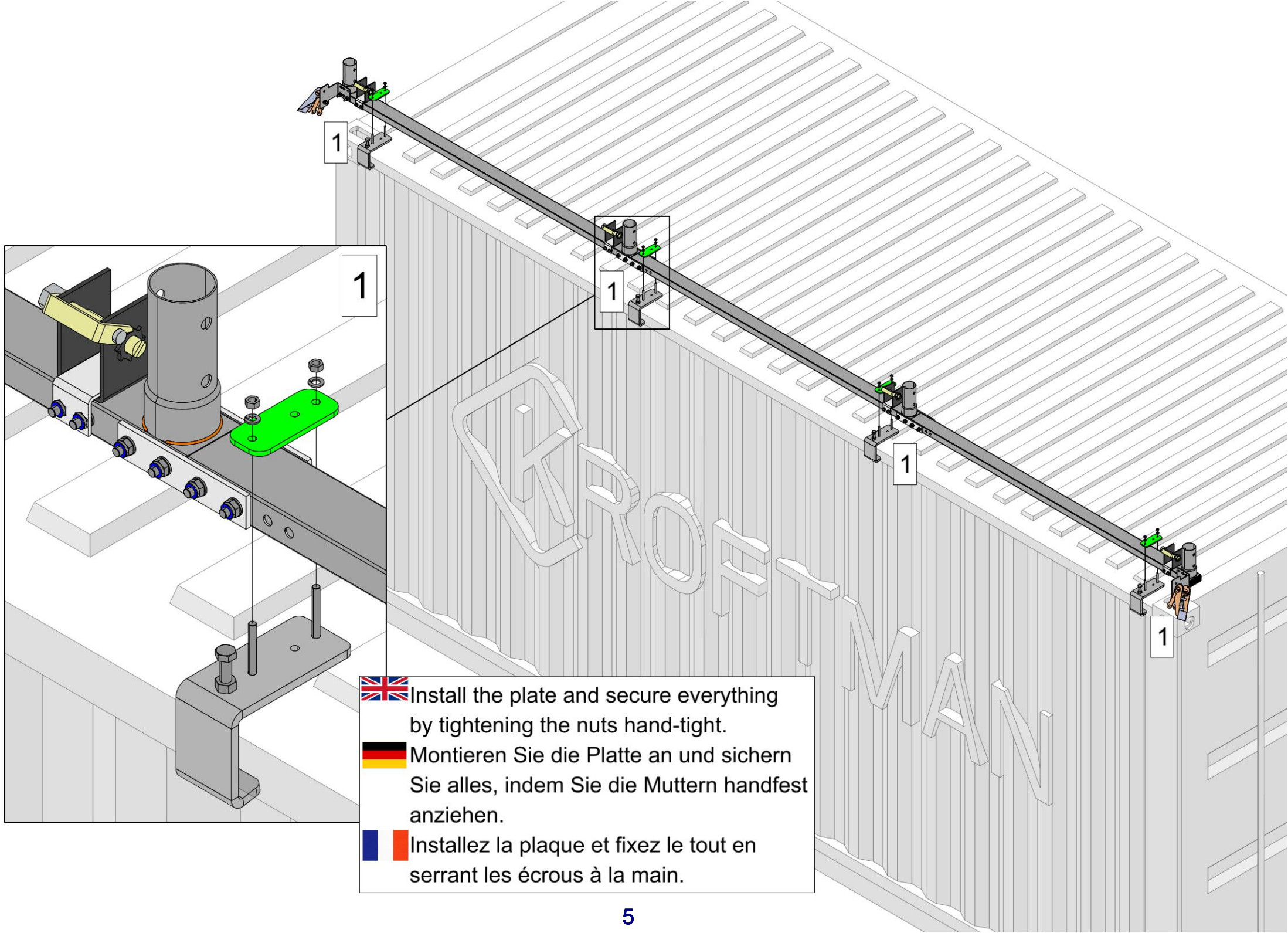
 Placer et aligner symétriquement le rail de base sur le dessus du conteneur. Marquer la position des pinces TCA0008 le plus près possible des tubes, retirer le rail de base et placer les pinces. Mettez les pinces à niveau et serrez les écrous à la main.



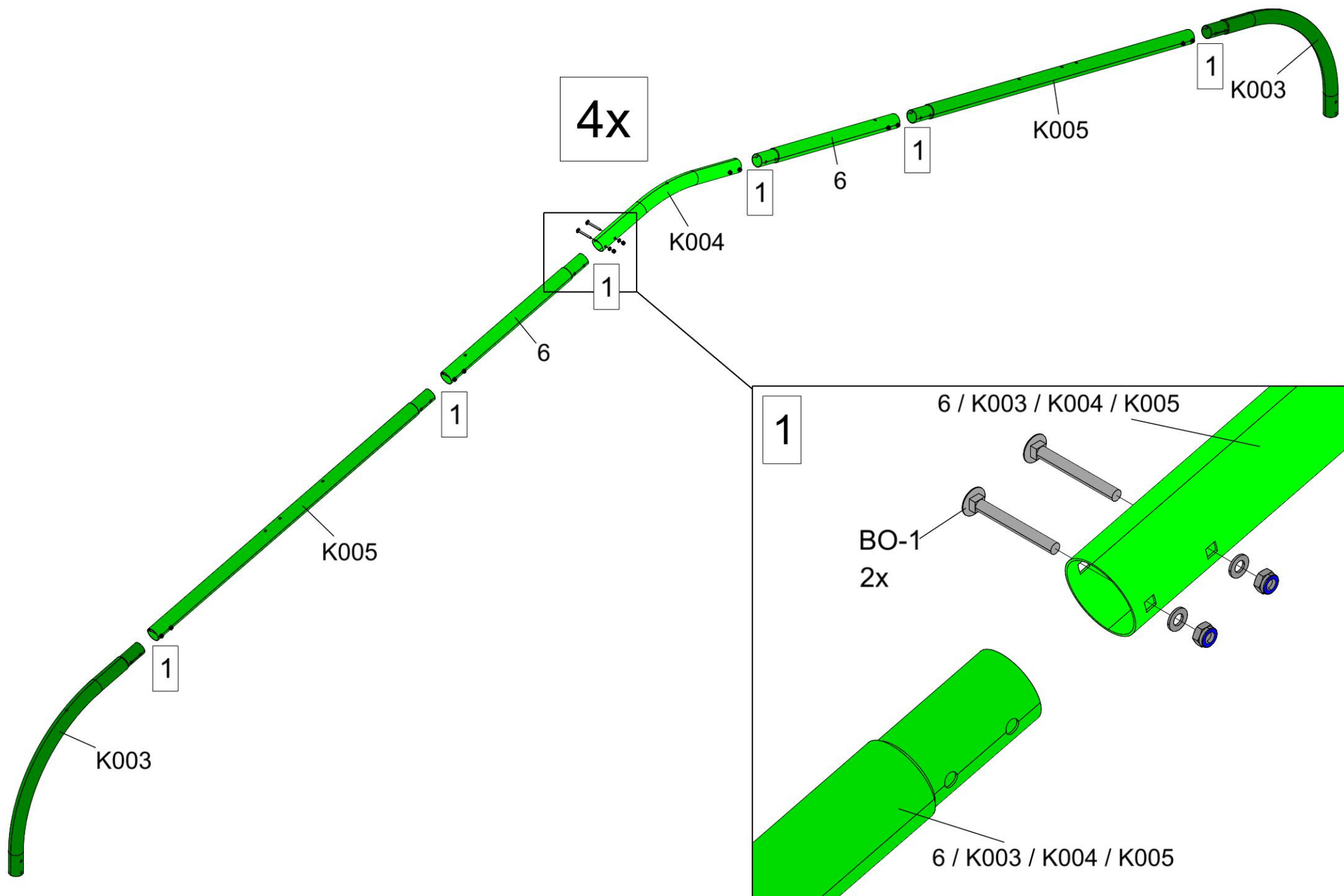

-  Install the plate and secure everything by tightening the nuts hand-tight.
-  Montieren Sie die Platte an und sichern Sie alles, indem Sie die Muttern handfest anziehen.
-  Installez la plaque et fixez le tout en serrant les écrous à la main.



 When placing the first and last arch make sure the boltheads point outwards
 Achten Sie beim Anbringen des ersten und letzten Bogens darauf, dass der Schraubenkopf nach außen zeigt.
 Lorsque vous placez le premier et le dernier arc, veillez à ce que la tête de boulon soit orientée vers l'extérieur.

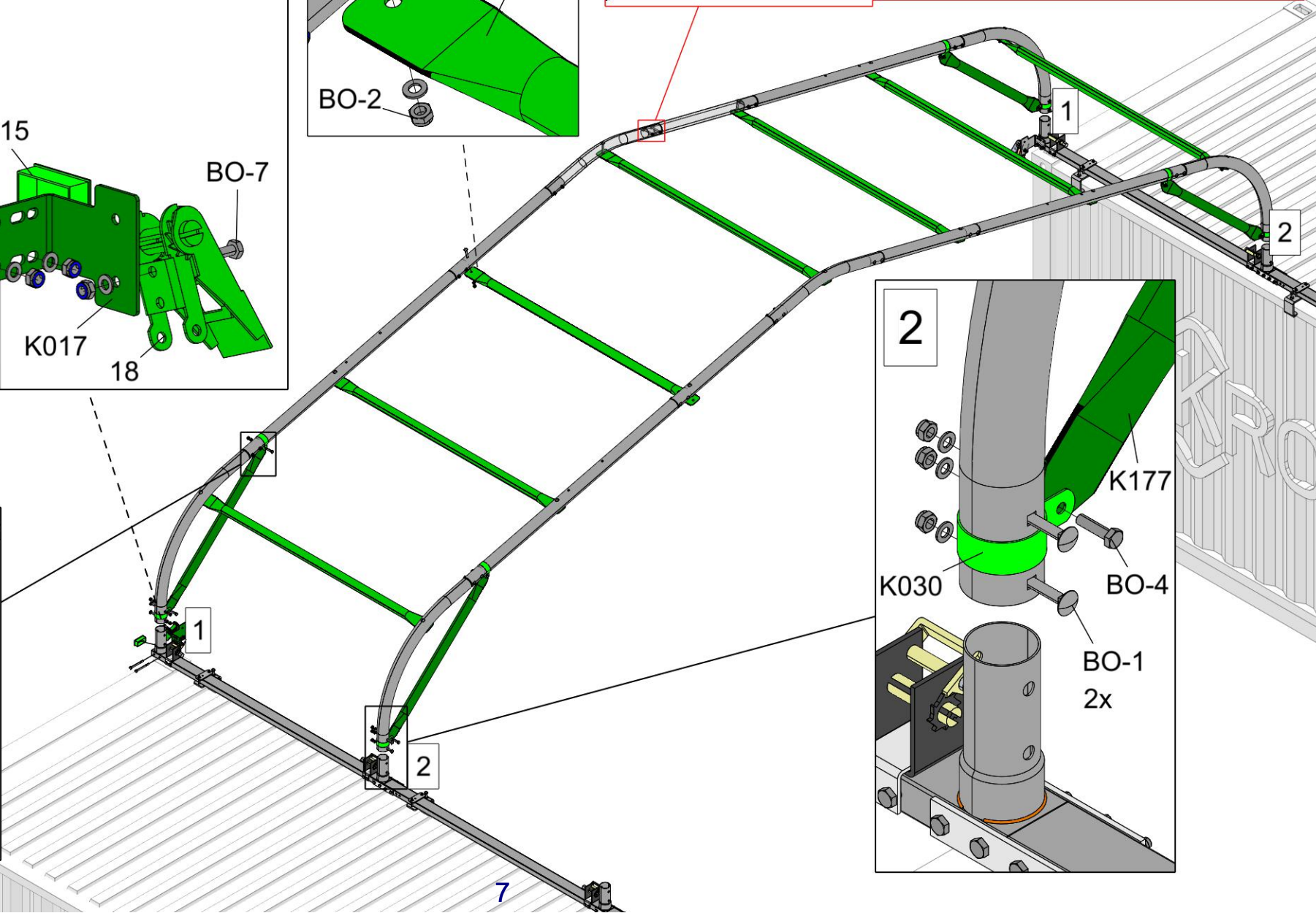
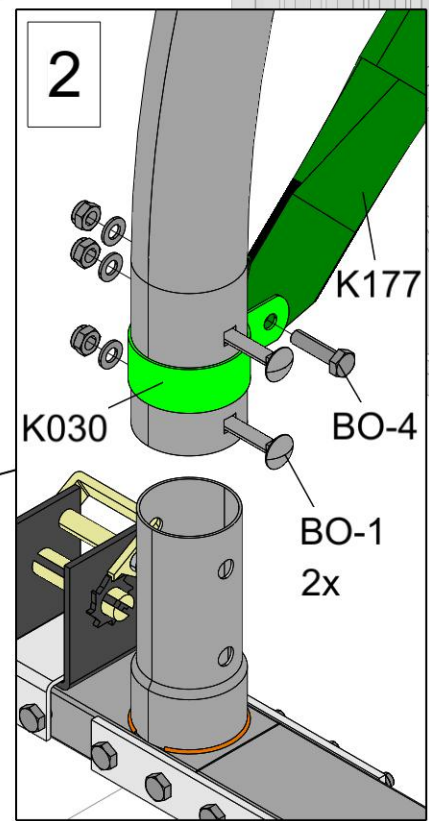
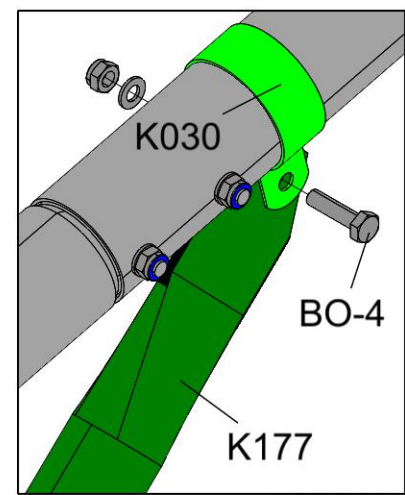
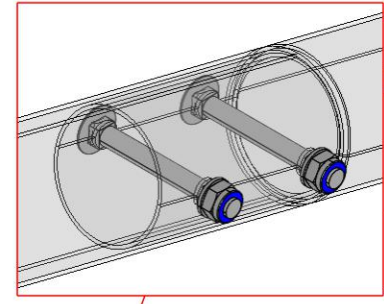
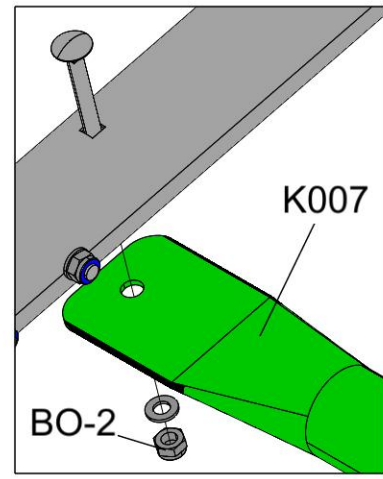
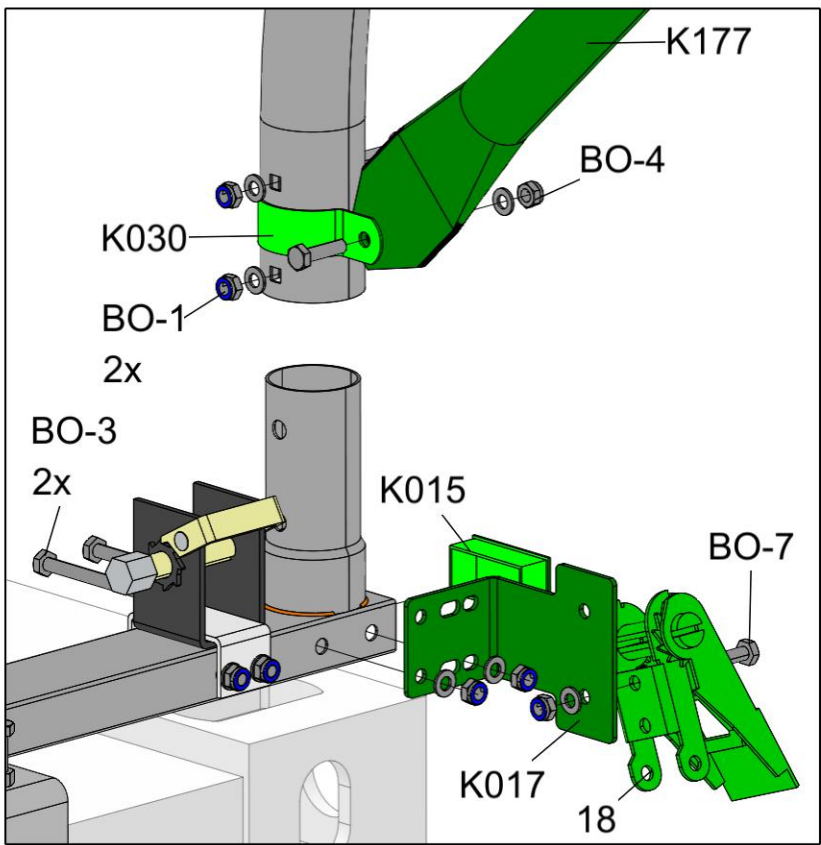

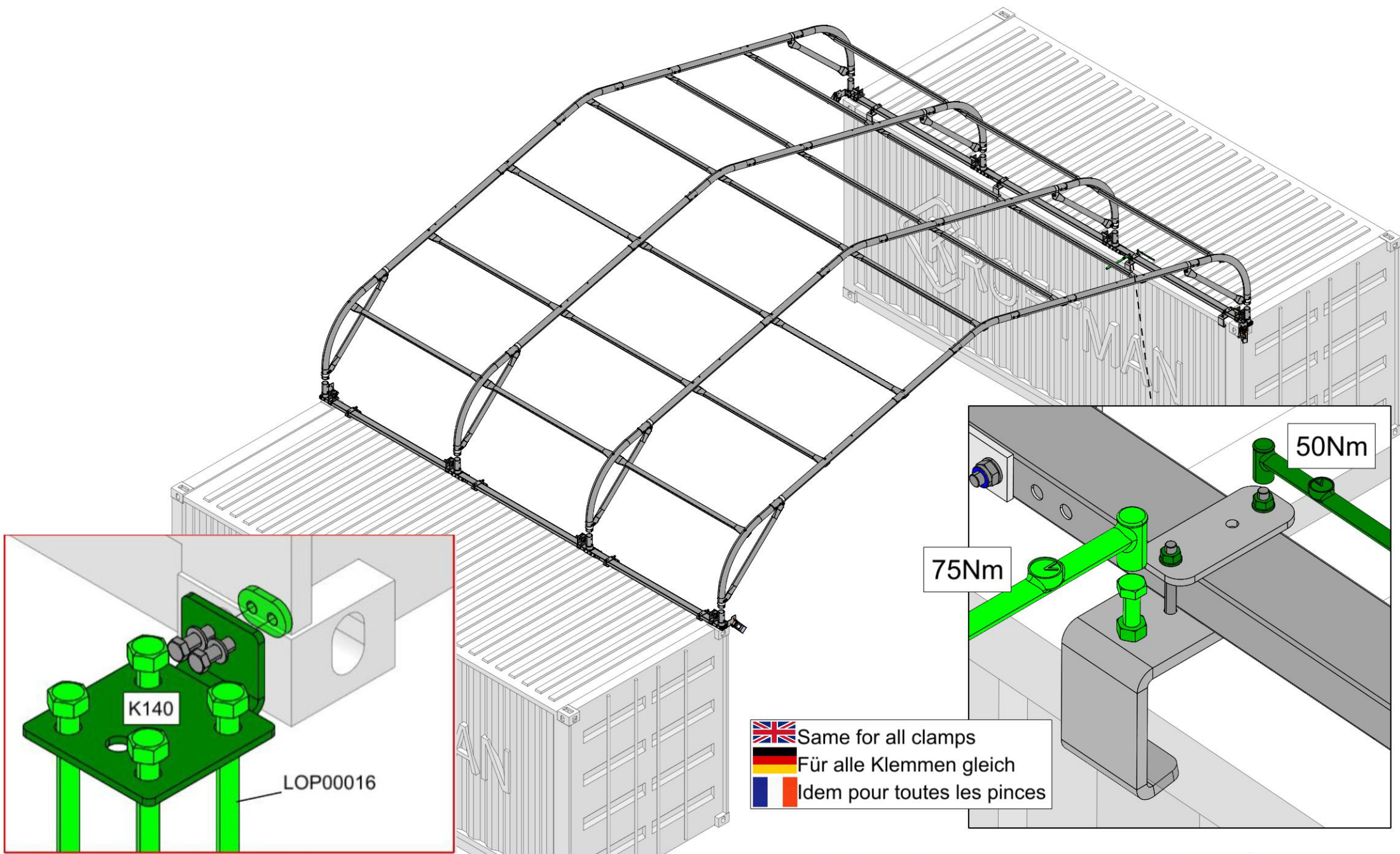

UK Important: add permanent weight in containers according to calculations or use optional container anchoring bracket.

DE Wichtig: Fügen Sie den Containern ein dauerhaftes Gewicht gemäß den Berechnungen hinzu oder verwenden Sie die optionalen Container- Verankerungsklammern.

FR Important : ajoutez le poids permanent dans les conteneurs selon les calculs ou utilisez le support d'ancrage de conteneur en option.